

ABB AC31 Programming

Software for operating the
MODBUS communication processor
07 KP 93

Order No.: GJP5 2072 00 R0102

Software Registration Form / Individual License
General License Conditions for the Supply of
Computer Software upon Payment of a Non-
Recurring License Fee (ALCN) / Floppy Disks **1**

Hardware 07 KP 93 R1163 **2**

Installation **3**

4

5

6

MODBUS communication / Connection elements **7**

8

9

24 mm

ABB	ABB	ABB	ABB	ABB	ABB
Programming Software	Programming Software	Programming Software	Programming Software	Programming Software	Programming Software
907 KP 93 AC31	907 KP 93 AC31	907 KP 93 AC31	907 KP 93 AC31	907 KP 93 AC31	907 KP 93 AC31
GJP5 2072 00	GJP5 2072 00	GJP5 2072 00	GJP5 2072 00	GJP5 2072 00	GJP5 2072 00

59 mm

ABB	ABB	ABB	ABB	ABB	ABB
Programming Software	Programming Software	Programming Software	Programming Software	Programming Software	Programming Software
907 KP 93 AC31	907 KP 93 AC31	907 KP 93 AC31	907 KP 93 AC31	907 KP 93 AC31	907 KP 93 AC31
GJP5 2072 00	GJP5 2072 00	GJP5 2072 00	GJP5 2072 00	GJP5 2072 00	GJP5 2072 00

ABB	ABB	ABB	ABB	ABB	ABB
Programming Software	Programming Software	Programming Software	Programming Software	Programming Software	Programming Software
907 KP 93 AC31	907 KP 93 AC31	907 KP 93 AC31	907 KP 93 AC31	907 KP 93 AC31	907 KP 93 AC31
GJP5 2072 00	GJP5 2072 00	GJP5 2072 00	GJP5 2072 00	GJP5 2072 00	GJP5 2072 00

ABB	ABB	ABB	ABB	ABB	ABB
Programming Software	Programming Software	Programming Software	Programming Software	Programming Software	Programming Software
907 KP 93 AC31	907 KP 93 AC31	907 KP 93 AC31	907 KP 93 AC31	907 KP 93 AC31	907 KP 93 AC31
GJP5 2072 00	GJP5 2072 00	GJP5 2072 00	GJP5 2072 00	GJP5 2072 00	GJP5 2072 00

Notes on completing the software registration form

Please complete the software registration forms in full and using a typewriter or in block capitals. Please return the "Double" to ABB. Do not forget to sign the software registration forms!

In order to prevent difficulties or delays in provision of software updates to you, the software registration form should contain the following information:

Licensee

Name or company: Full company name
Department/Contact person/Phone: Name of department, name and telephone No. of contact person
Address: Street/road and number of P.O. Box, country code, postal code, town/city
Date of delivery: Already completed (if you do not have this information, please
(as defined in ALCN 4.1) enter the day of reception)
Name/legally binding signature: Name in block capitals and signature

Customer Hardware (PC)

Hardware manufacturer: Manufacturer of the PC used (e.g. Compaq)
Type: Precise type designation of the PC (e.g. 80486DX, 33 MHz)

Software Product

Product name: Designation of the software (e.g. 907 PC 331; already completed)
Version: Version number (already completed)
Identification No.: Identification No. of the software (already completed)
Serial No.: Production date of the diskettes (e.g. 12.98 = December 1998; already completed)
ABB order No. or ABB office: ABB order No. or ABB field office which supplied the software (already completed)
New software version should be offered according to ALCN 6.2 State whether new software versions are to be offered in accordance with ALCN 6.2

Specification in accordance with item 5.2 ALCN

General description

The software 907 KP 93 contains all additional function blocks which are necessary to operate the 07 KP 93 module at the basic units 07 KT 92, 07 KT 93 and 07 KT 94.

Features of the 07 KP 93 module

The 07 KP 93 communication processor is an interface module with 2 serial MODBUS RTU interfaces.

The communication processor allows external units to be connected to the Advant Controller 31 system using the MODBUS RTU protocol.

The most important features of the communication processor are:

- 2 serial interfaces:
usable in accordance with EIA RS-232 or
EIA RS-485 (COM3, COM4)

Possible operating modes:

COM3 COM4

Master Slave (Master-master does not work)

Slave Master

Slave Slave

- The communication with AC 31 basic units is performed with function blocks / connection elements which are provided with the software diskette.

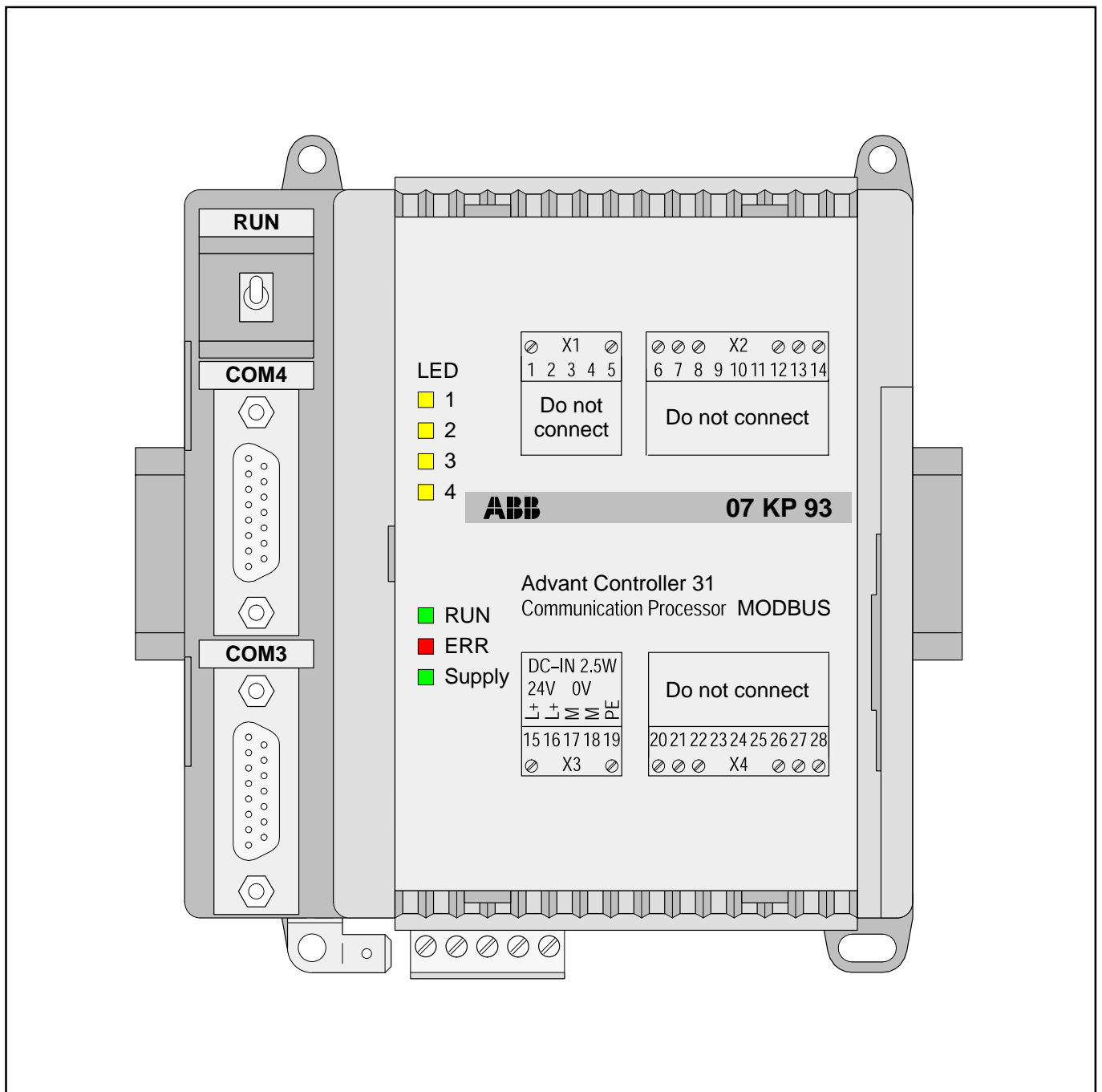

Regulations Concerning the Setting up of Installations

Apart from the basic "Regulations of the Setting up of Power Installations" DIN VDE 0100 and for "The Rating of Creepage Distances and Clearances" DIN VDE 0110 Part 1 and Part 2 the regulations "The Equipment of Power Installations with Electrical Components" DIN VDE 0160 in conjunction with DIN VDE 0660 Part 500 have to be taken into due consideration.

Further attention has to be paid to DIN VDE 0113 Part 1 and Part 200 in case of the control of working and processing machines. If operating elements are to be mounted near parts with dangerous contact voltage DIN VDE 0106 Part 100 is additionally relevant.

If the protection against direct contact according to DIN VDE 0160 is required, this has to be ensured by the user (e.g. by incorporating the elements in a switch-gear cabinet). The devices are designed for pollution severity 2 in accordance with DIN VDE 0110 Part 1. If higher pollution is expected, the devices must be installed in appropriate housings.

The user has to guarantee that the devices and the components belonging to them are mounted following these regulations. For operating the machines and installations, other national and international relevant regulations, concerning prevention of accidents and using technical working means, also have to be met.

Devices of Advant Controller 31 Series (AC31) are designed according to IEC 1131 Part 2. Meeting this regulation, they are classified in overvoltage category II which is in conformance with DIN VDE 0110 Part 2.

For the direct connection of AC31 devices, which are powered with or coupled to AC line voltages of overvoltage category III, appropriate protection measures corresponding to overvoltage category II according to IEC-Report 664/1980 and DIN VDE 0100 Part 1 are to install.

Equivalent standards:

DIN VDE 0110 Part 1 ↔ IEC 664

DIN VDE 0113 Part 1 ↔ EN 60204 Part 1

DIN VDE 0660 Part 500 ↔ EN 60439-1 ↔ IEC 439-1

All rights reserved to change design, size, weight, etc.

* VDE stands for "Association of German Electrical Engineers".

1 Communication processor 07 KP 93 R1161

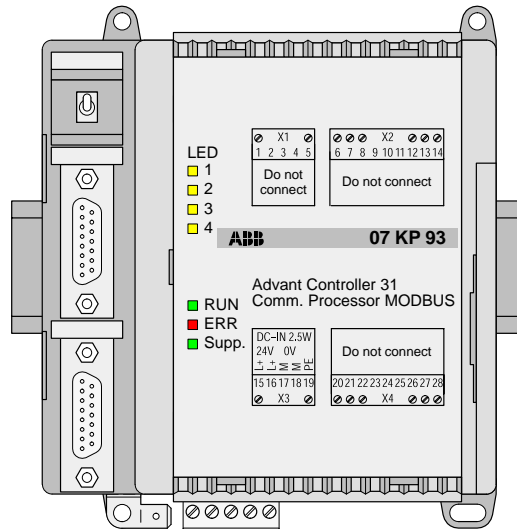

Fig. 1: Communication processor 07 KP 93 R1161

Contents

1.1	Brief description	1
1.2	Structure of the front panel elements	2
1.3	Electrical connection	2
1.3.1	Application example	3
1.3.2	Connecting the supply voltage	4
1.3.3	Electrical isolation and earthing instructions	4
1.3.4	Serial interfaces	6
1.3.5	Networking interface	7
1.4	Diagnosis	8
1.5	Technical data	9
1.6	System cables	12
1.7	MODBUS RTU	13
1.8	MODBUS protocol	16
1.9	Function blocks	18

1.1 Brief description

The 07 KP 93 communication processor is an interface module with 2 serial MODBUS RTU interfaces.

The communication processor allows external units to be connected to the Advant Controller 31 system using the MODBUS RTU protocol.

The most important features of the communication processor are:

- 2 serial interfaces: usable in accordance with EIA RS-232 or EIA RS-485 (COM3, COM4)

Possible operating modes:

COM3	COM4	
Master	Slave	(Master-master does not work)
Slave	Master	
Slave	Slave	

- Communication with AC 31 basic units is performed with 2 function blocks / connection elements (see also programming software 907 KP 93).

Contact person

If you have any questions concerning the use of MODBUS, please ask our helpline:

ABB Schalt- und Steuerungstechnik GmbH
SST/MPE
Eppelheimer Straße 82
D-69123 Heidelberg

Telephon: +49 6221 777-444
Telefax: +49 6221 777-361
EMail: desst.helpline@de.abb.com
Internet: http://www.abb-sst.de

1.2 Structure of the front panel

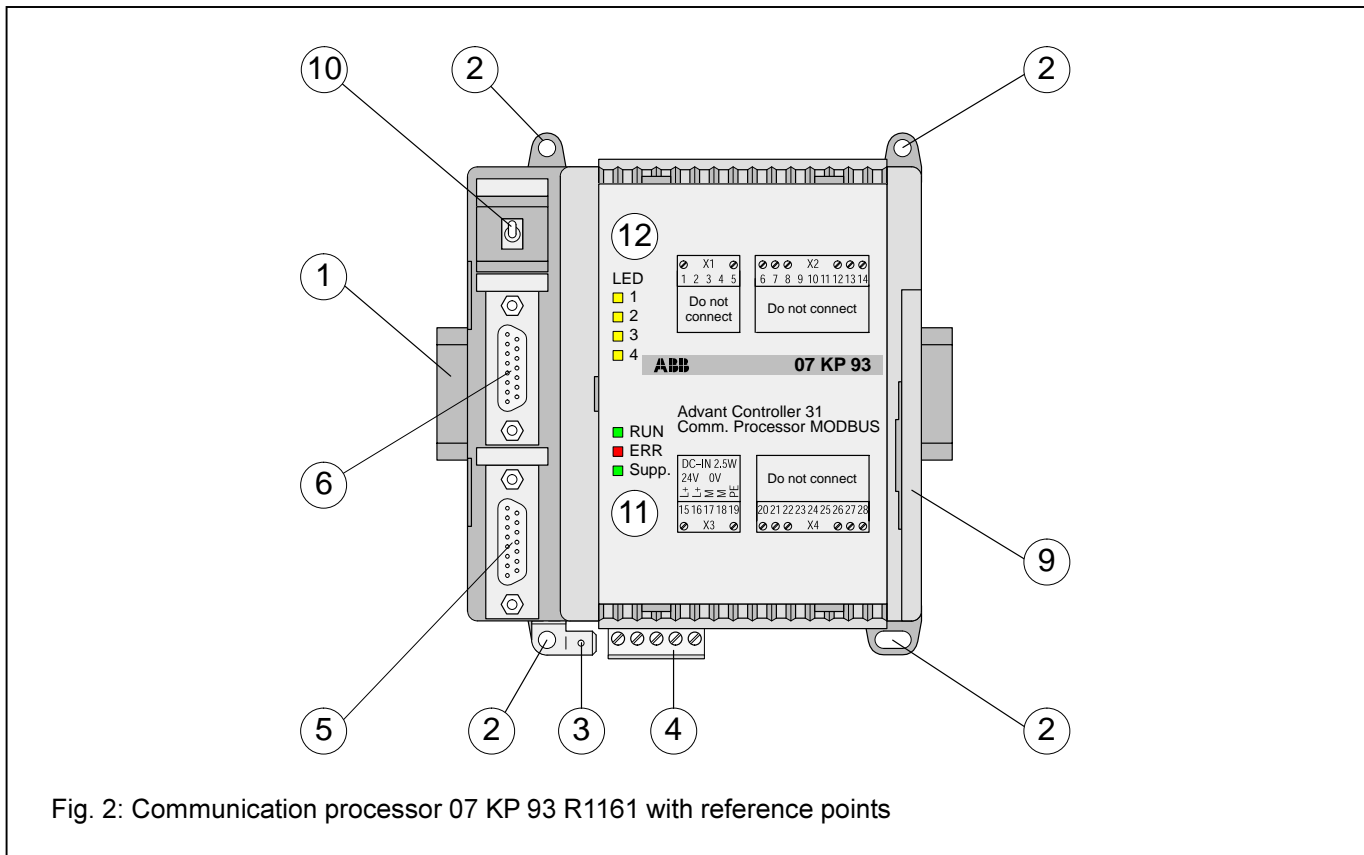

Fig. 2: Communication processor 07 KP 93 R1161 with reference points

1 Mounting the unit on a DIN rail

2 Mounting the unit with screws

3 6.3 mm Faston earthing terminal

4 24 V DC supply voltage

5 Serial interface COM3

6 Serial interface COM4

9 Networking interface for the Advant Controller 31 basic unit

10 Switch not used

11 LED displays for system messages

Refer to chapter 1.4 Diagnosis for further information

12 LED displays for system messages

Refer to chapter 1.4 Diagnosis for further information

12

yellow

yellow

yellow

yellow

11

green

red

green

LED1

LED2

LED3

LED4

RUN

ERR

Supply

1.3 Electrical connection

1.3.1 Application example

The following illustration shows an application example with the 07 KT 94 basic unit.

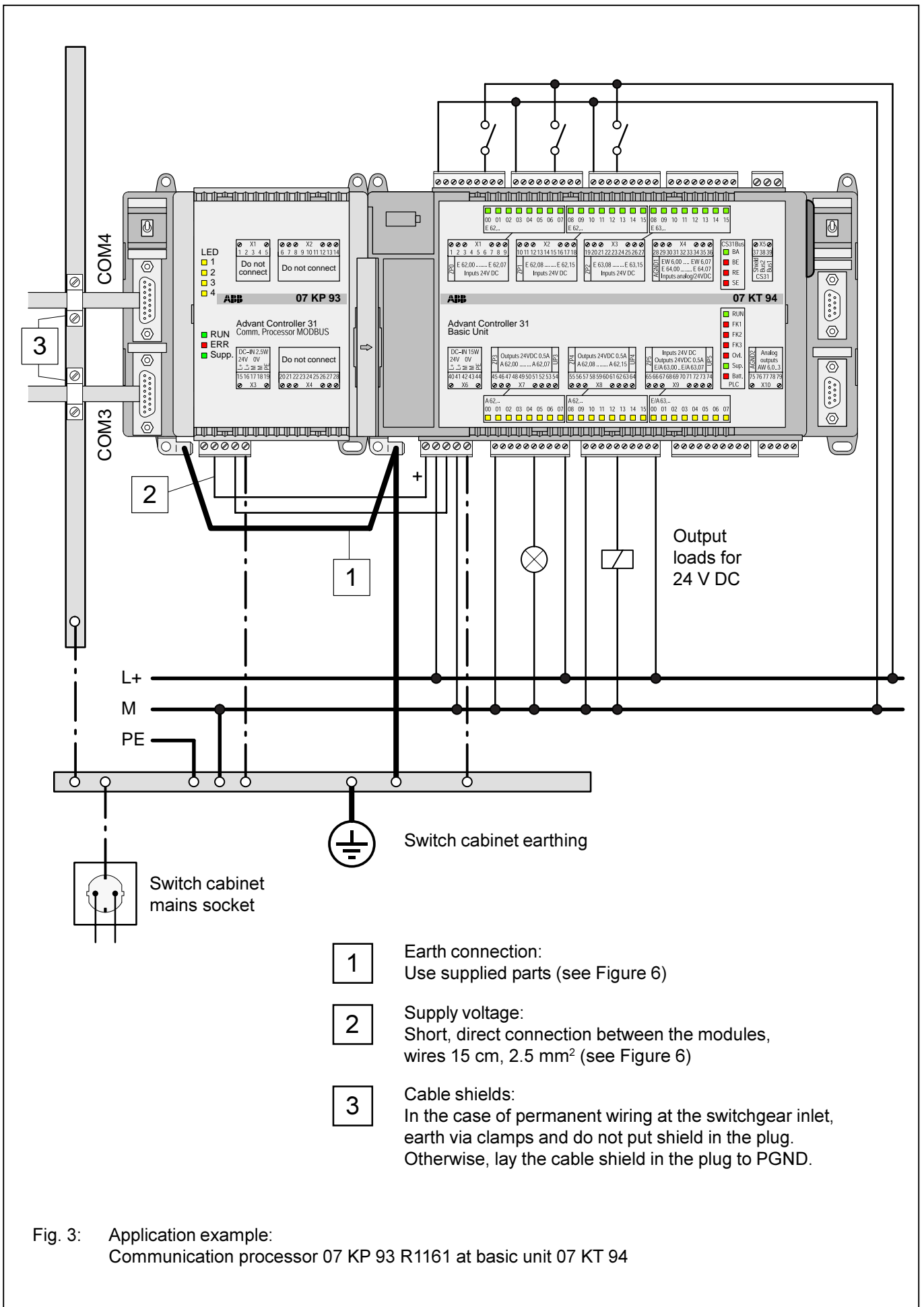

Fig. 3: Application example:
Communication processor 07 KP 93 R1161 at basic unit 07 KT 94

1.3.2 Connecting the 24 V DC supply voltage

The supply voltage is fed in via a 5-pole detachable terminal block.

Important:

Plug and unplug terminal block only with power is off!

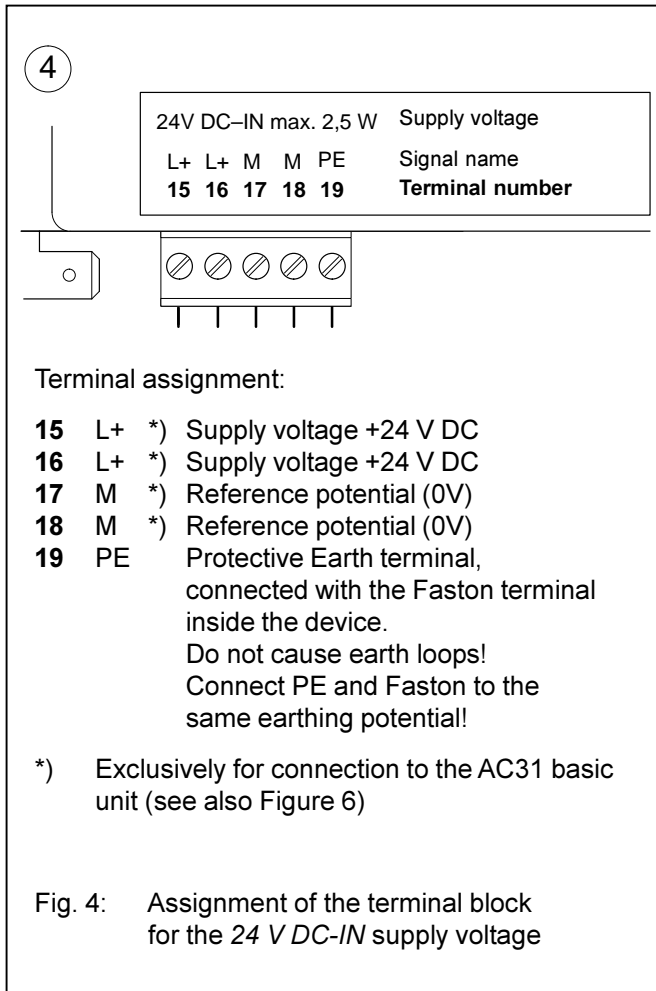

Fig. 4: Assignment of the terminal block for the 24 V DC-IN supply voltage

1.3.3 Electrical isolation and notes on earthing

The Protective Earth is connected to the 6.3 mm Faston terminal via a wire with a cross section of 6 mm² (maximum length 25 cm).

The signals of the interfaces COM3 and COM4 are electrically isolated from each other and also from the internal electronics of the unit.

The following illustration shows which parts of the unit are connected to PE/PGND.

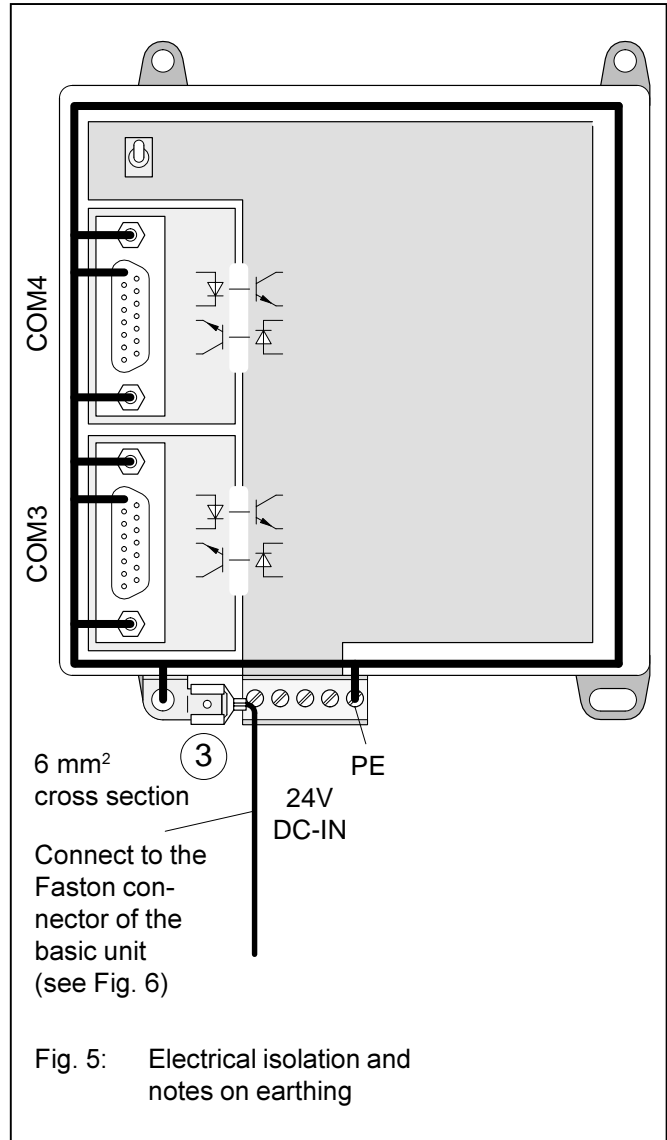
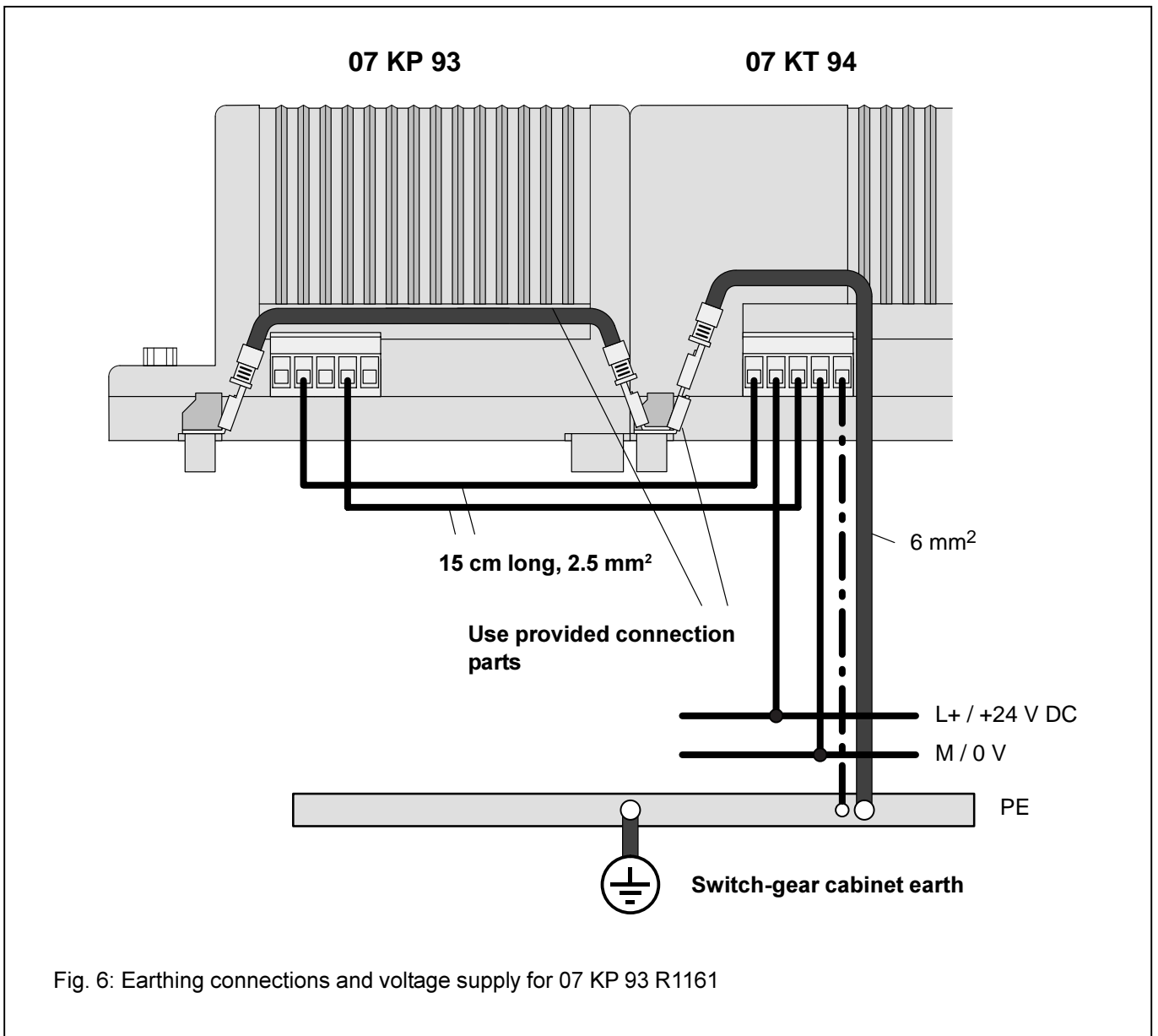
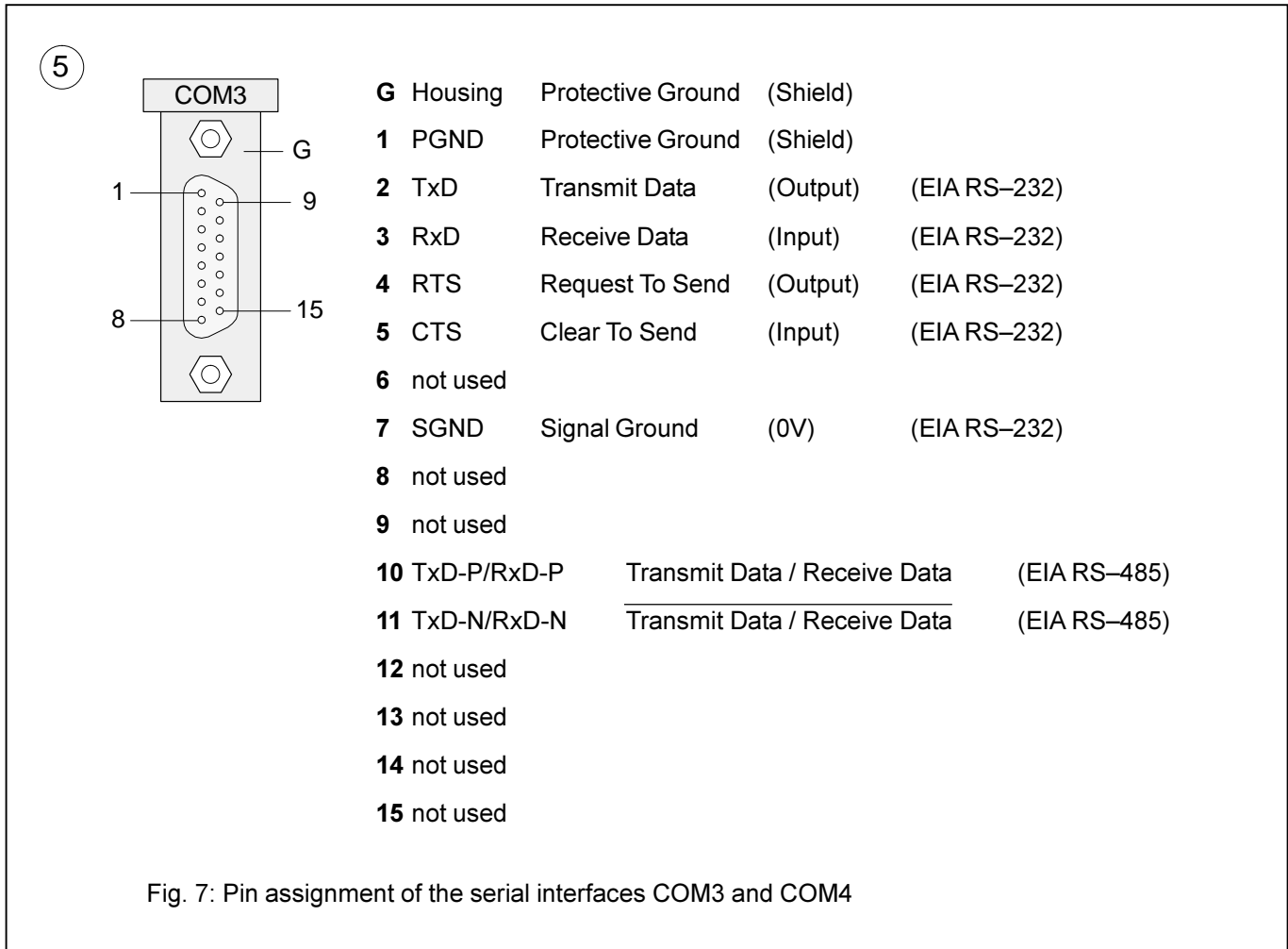

Fig. 5: Electrical isolation and notes on earthing



1.3.4 Serial interfaces COM3 and COM4: Pin assignment

Interface standard: EIA RS-232, EIA RS-422, EIA RS-485



1.3.5 Networking interface

9

The communication processor can be connected to AC31 basic units of the 90 series which have a networking interface. The housing of the communication processor is

connected to the housing of the AC31 basic unit by a snap-fit connection. The electrical connection is via a 40-pole ribbon cable with socket connector, soldered onto the 07 KP 93 side.

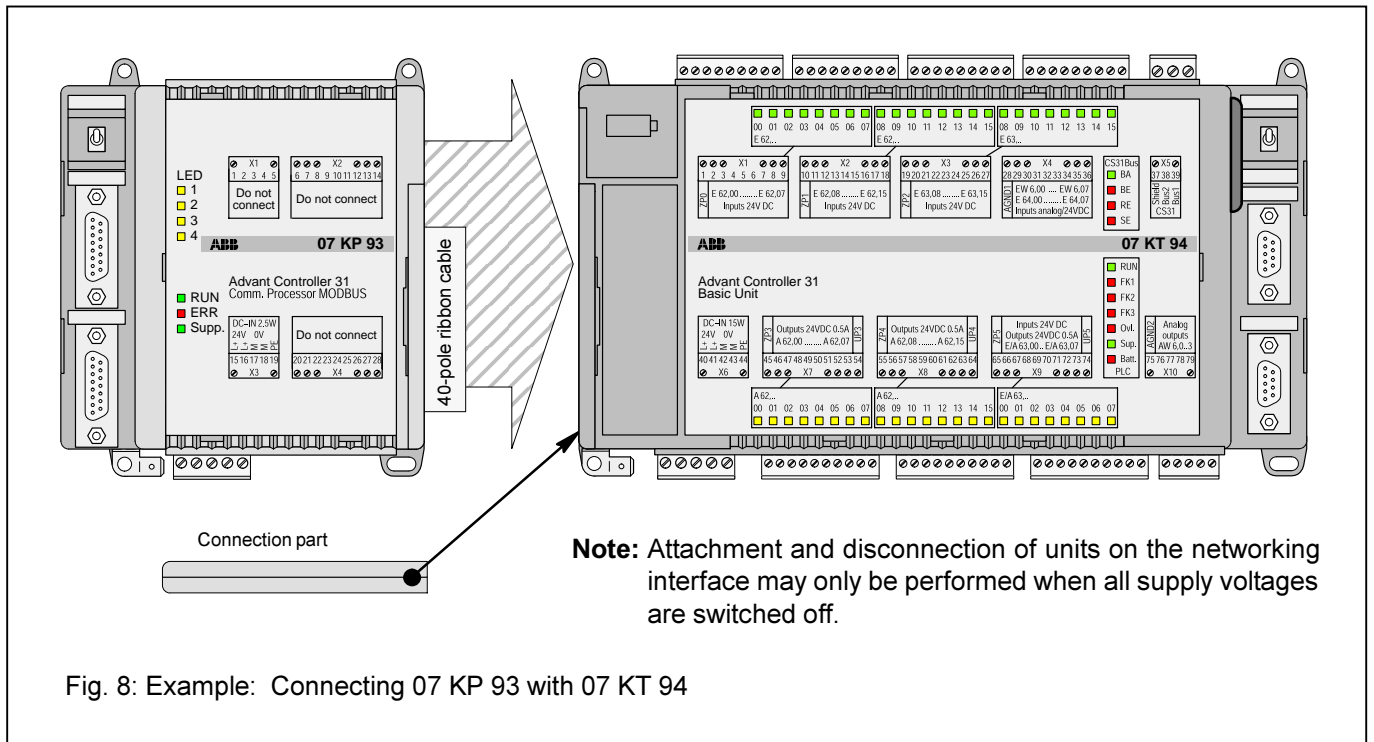

Fig. 8: Example: Connecting 07 KP 93 with 07 KT 94

Mounting the expansion housing

1. Detach the cover on unit 07 KT 94 from the networking interface.
2. Plug the socket strip of the 40-pole ribbon cable secured to the 07 KP 93 onto the networking connector of the 07 KT 94.
3. Place both units on a level surface and slide them together so that they engage.
4. Slide in the connection part to fix the housing in position.

1.4 Diagnosis

LED displays for system messages RUN, ERR, Supply

11

green	<input type="checkbox"/> RUN
red	<input type="checkbox"/> ERR
green	<input type="checkbox"/> Supply

Alternately flashing of the RUN LED and the ERR LED means that none of the interfaces was initialized.

The green LED "Supply" indicates the presence of the supply voltage.

Fig. 9: LED displays for system messages
RUN, ERR, Supply

LED displays LED1...LED4

12

yellow	<input type="checkbox"/> LED1
yellow	<input type="checkbox"/> LED2
yellow	<input type="checkbox"/> LED3
yellow	<input type="checkbox"/> LED4

LED1 on: Master operation: COM3 has received a valid and applicable answer message,
slave operation: COM3 has received a valid and applicable inquiry message.

LED2 on: same as LED1 on, but valid for COM4

LED3 on: COM3 initialized

LED4 on: COM4 initialized

Fig. 10: LED displays LED1...LED4

1.5 Technical data

In general, the details in section 1 "System data and system structure" of volume 2 of the system description "Advant Controller 31" apply as technical data. Supplementary and deviating data is listed below.

1.5.1 General data

Number of serial interfaces	2
Number of parallel interfaces	1 networking interface for connecting to the Advant Controller 31 basic unit
Diagnosis	4 LEDs: LED1...LED4
Operating and error displays	3 LEDs: RUN, ERR, Supply
Conductor cross section for the removable terminal blocks	max. 2.5 mm ²

1.5.2 Supply voltage for 07 KP 93 R1161

Rated supply voltage	24 V DC
Power dissipation	typ. 2.5 W (max. 5W)
Max. current consumption with rated voltage with supply voltage 30 V	210 mA 170 mA
Protection against reversed terminal connection	yes

1.5.3 Connection serial interface COM3, COM4

Interface standard	EIA RS-232 or EIA RS-485
Electrical isolation	yes, interfaces with respect to each other and with respect to the rest of the unit (also see Figure 5)
Terminal assignment and description of the interfaces COM3, COM4	see page 6

1.5.4 LED displays

– Supply	1 green LED
– ERR	1 red LED
– RUN	1 green LED
– LED1...LED4	4 yellow LEDs

description see chapter 1.4 Diagnosis

1.5.5 Mechanical data

Mounting on DIN rail

in accordance with DIN EN 50022–35, 15 mm deep.
The DIN rail is located in the middle between the upper and the lower edges of the module.

Fastening by screws

using 4 M4 screws.

Width x height x depth

140 x 120 x 85 mm

Wiring method

by removeable terminal blocks with screw-type terminals, max. 2.5 mm²

Weight

450 g

Dimensions for mounting

see the following drawing

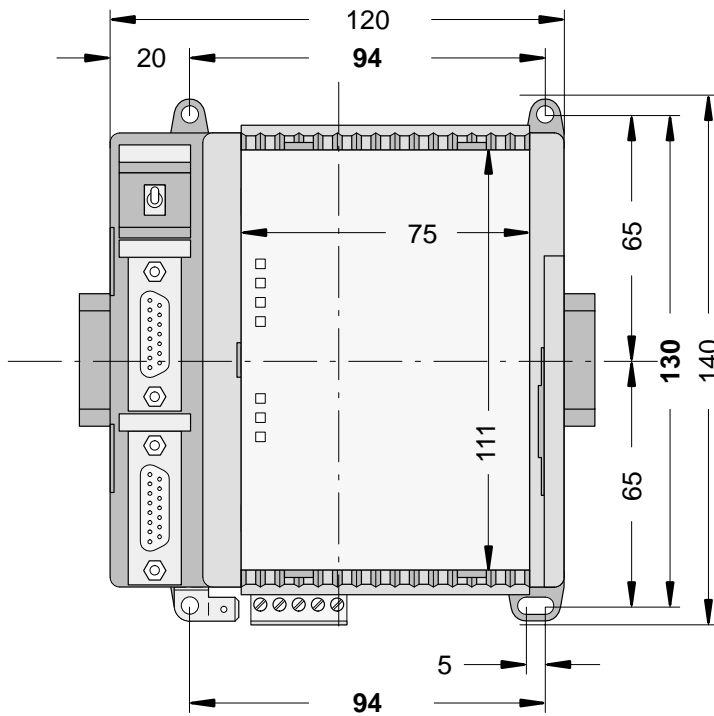

All dimensions in mm.

The device is 85 mm deep. The interface connectors COM3 and COM4 are set deeper so that the mounting depth required does not become any larger even with detachable interface cables. If, however, a DIN rail is used, the mounting depth is increased by the overall depth of the rail.

Fig. 11: Dimensions of the communication processor module 07 KP 93, front view, **the dimensions for assembly bore holes are printed in bold**

1.5.6 Mounting hints

Mounting position

vertical, terminals above and below

Cooling

The natural convection cooling must not hindered by cable ducts or other material mounted in the switch-gear cabinet.

1.5.7 Ordering data

Communication processor

07 KP 93 R1161 Order No. GJR5 2532 00 R1161

Scope of delivery

Communication processor 07 KP 93 R1161
1 5-pole terminal block (5.08 mm grid),
cable including terminals for making the
earth connection

Further literature

System description Advant Controller 31, English

Order No. 1SAC 1316 99 R0201

System description ABB Procontic T200

Order No. GATS 1314 99 R2001

Software

Software 907 KP 93

Order No. GJP5 2072 00 R0102

1.6 System cables

1.6.1 COM3, COM4 as EIA RS-232 interfaces

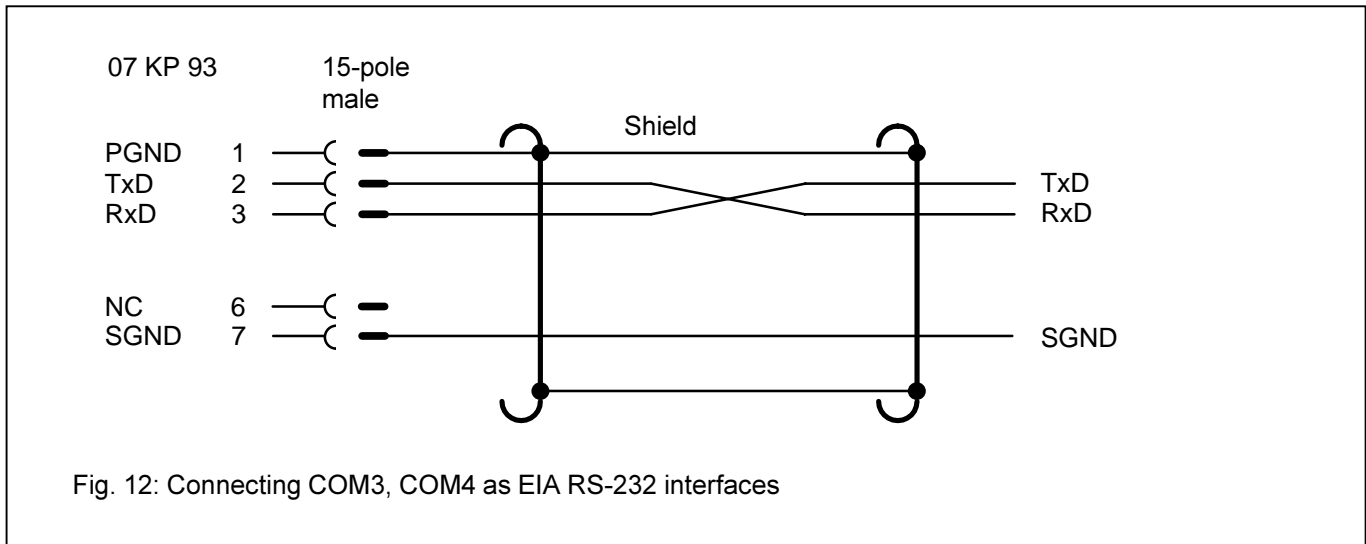

1.6.2 COM3, COM4 as EIA RS-485 interfaces

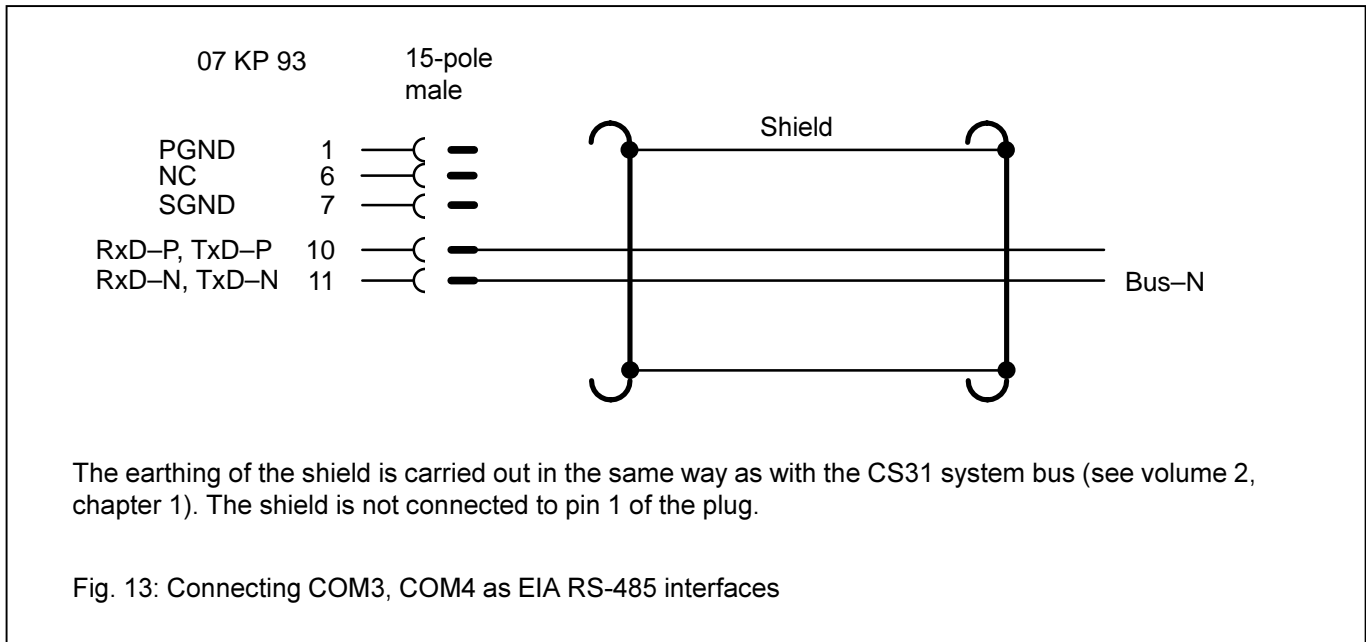

1.7 MODBUS-RTU

Overview

Brief description, field of application

MODBUS-RTU is an international widely known standard. The main application is the coupling in the local area for:

- Automation systems and PLCs,

- Operating terminals
- PC operating stations / master terminals

Short data

- Number of user stations with EIA RS-485: 32
- Distance with EIA RS-485: max. 1.2 km
- Connection of dedicated-line modems is possible

Networking alternatives

Multi-point line up to 1.2 km

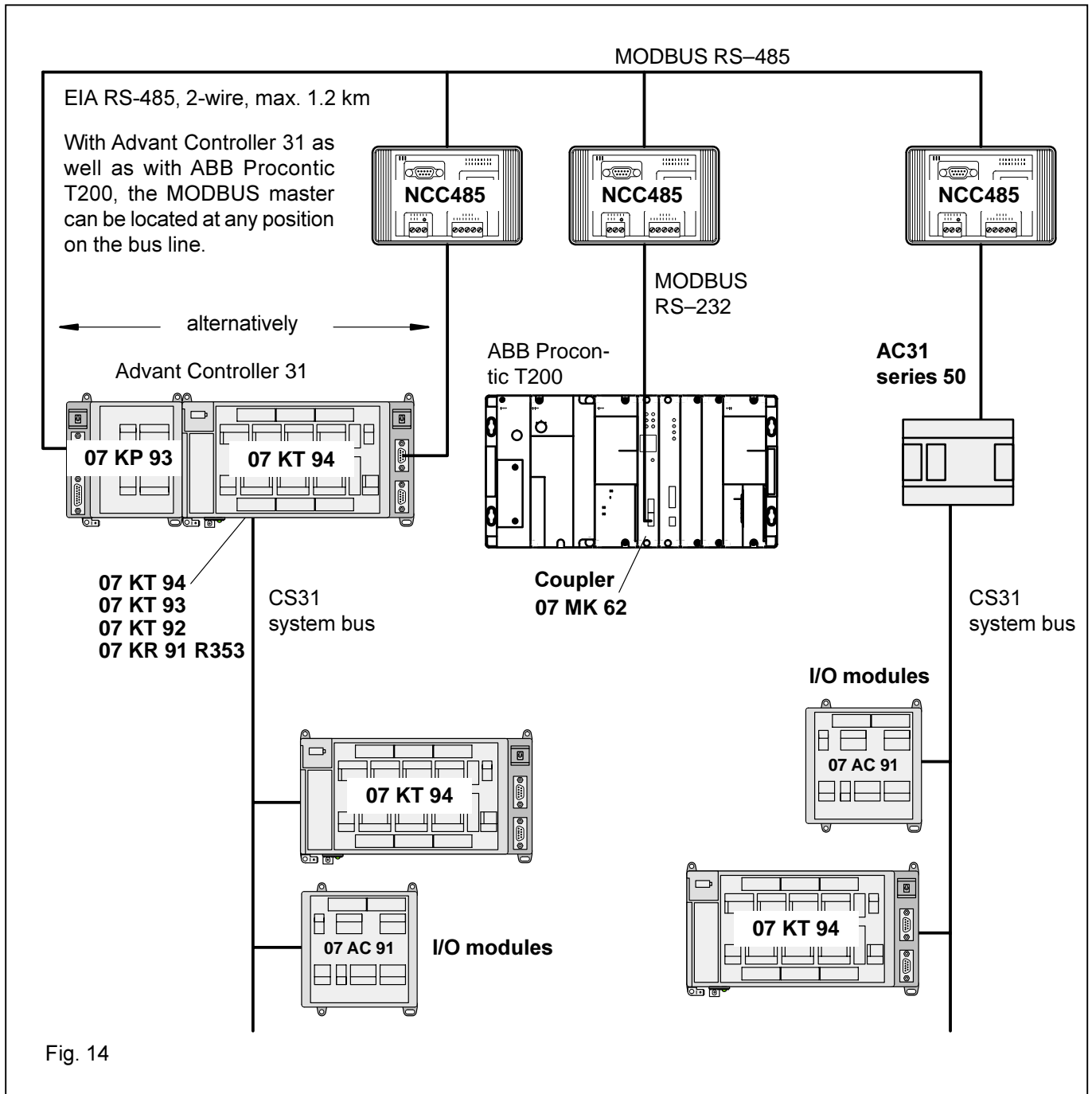

Installation example

Point-to-point without converter

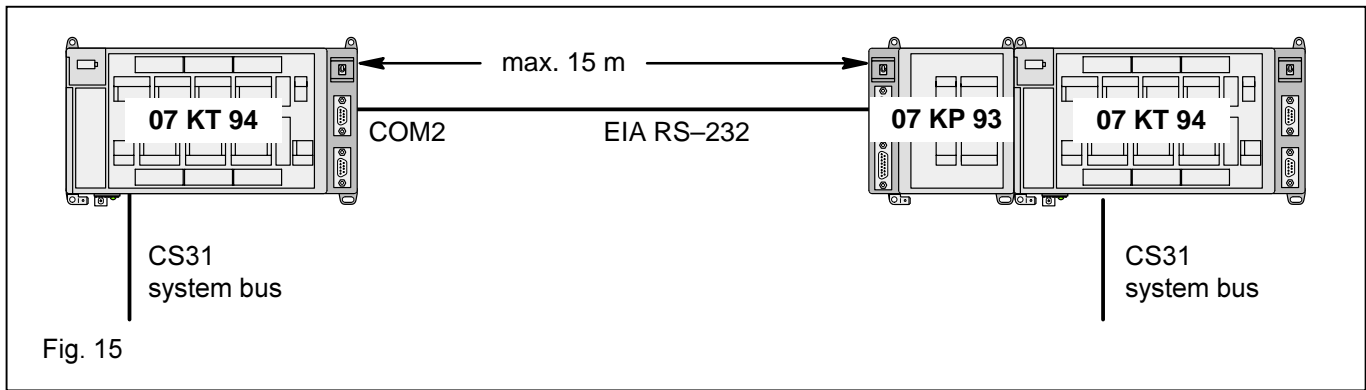

Multi-point line

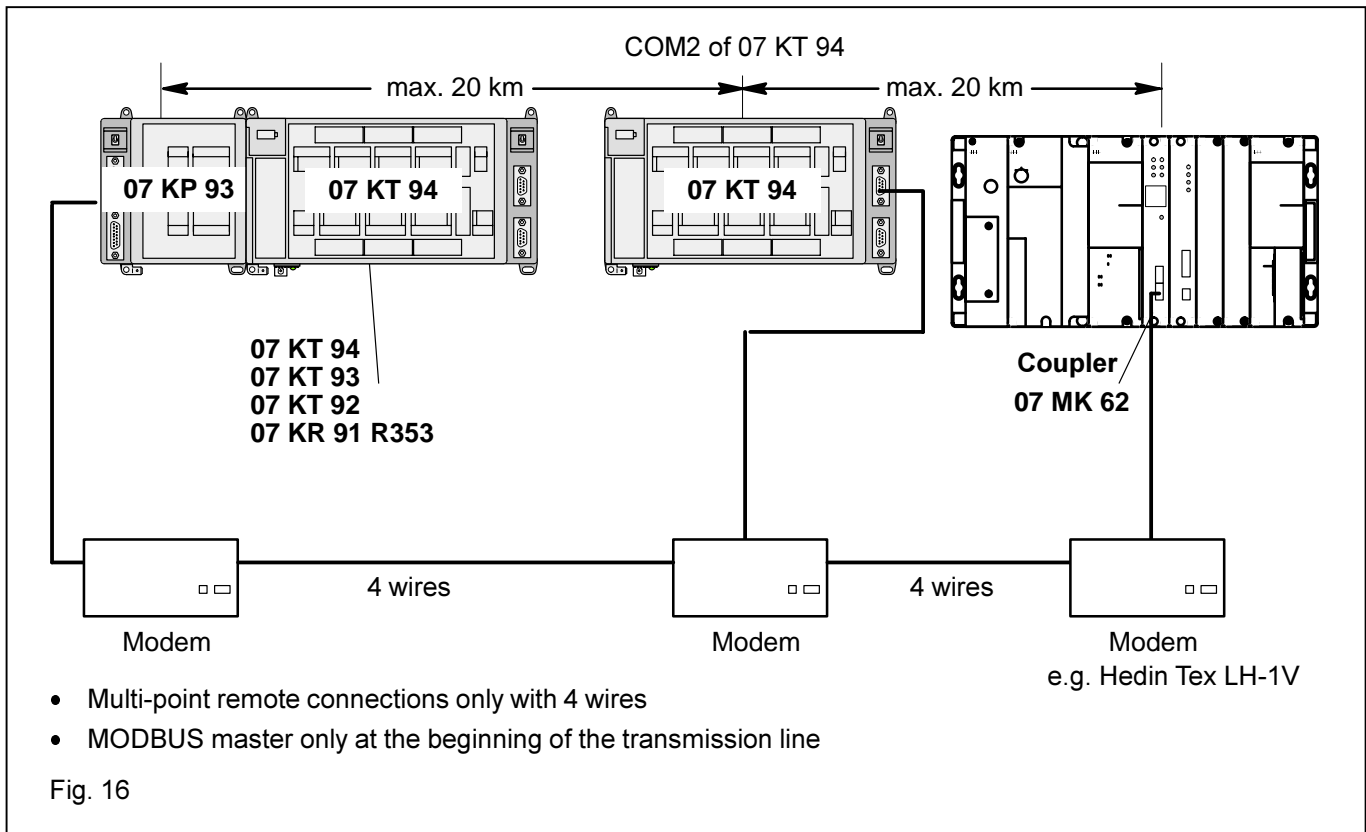

Point-to-point, max. 1200 bits/s, 4 wires

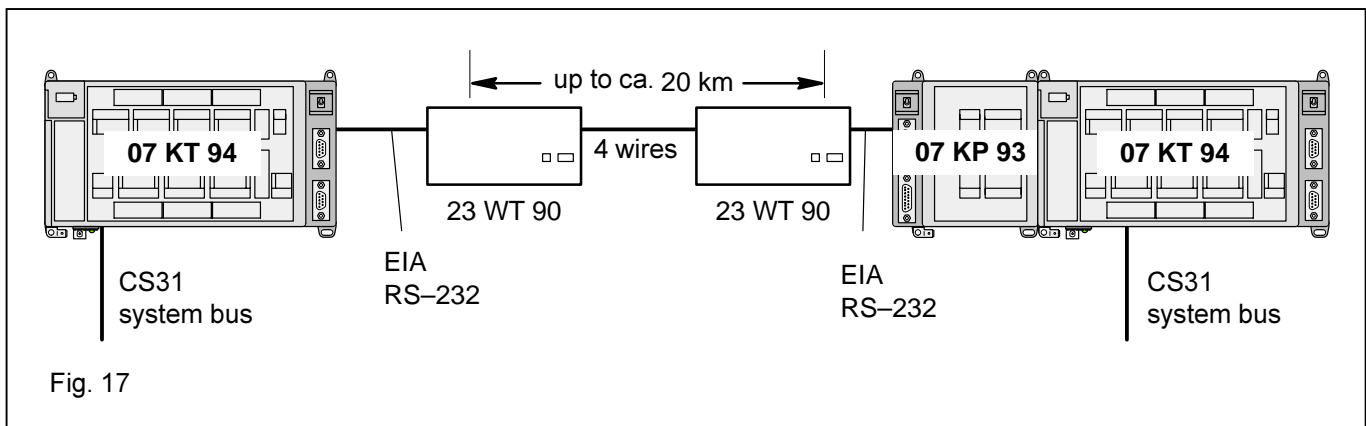

Separate connection of an operating terminal and an operating station via MODBUS

Use is made of the fact that the coupler 07 KP 93 R1161 has 2 MODBUS interfaces when used as slave (only as slave)

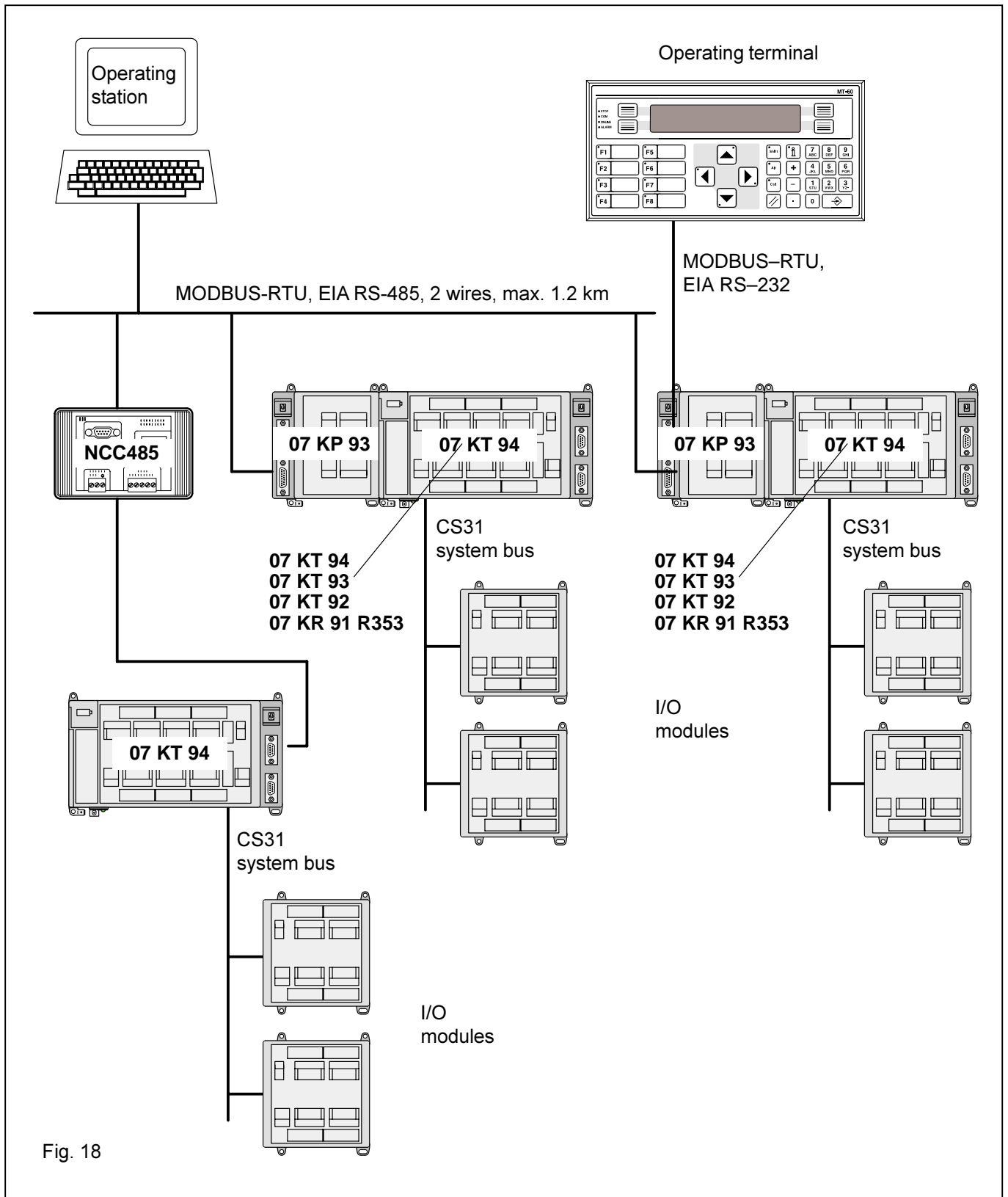

Fig. 18

The following connection elements are provided with the diskette in volume 1 of this binder. The CEs must be read-in into the 907 PC 331 library.

MOD_INI1	Initialization of the MODBUS master mode or slave mode (07 KP 93 at 07 KT 92 / 07 KT 93)
MOD_INI2	Initialization of the MODBUS master mode or slave mode (07 KP 93 at 07 KT 94)
MOD_MAS1	Realization of the MODBUS master function (07 KP 93 at 07 KT 92 / 07 KT 93)
MOD_MAS2	Realization of the MODBUS master function (07 KP 93 at 07 KT 94)

The description is in volume 7 of this binder.

MODBUS Communication
Connection Elements

Advant Controller 31
ABB Procontic CS31

Programming Software
907 KP 93 R0102

**ABB Schalt-
und Steuerungstechnik**



Table of Contents

- 1 Communication via the MODBUS interfaces COM3 and COM4** 1
- 2 Connection elements** 9
 - MOD_INI1 and MOD_INI2 10
 - MOD_MAS1 and MOD_MAS2 11
 - Example program with the connection elements 13

1 Communication via the MODBUS interfaces COM3 and COM4

1.1 Protocol description

The MODBUS protocol is used worldwide. The **MODICON MODBUS® RTU** protocol was integrated in the 07 KP 93 MODBUS coupler.

Numerous automation devices such as PLCs, displays, frequency converters or monitoring systems feature by default, or as an option, a MODBUS® RTU interface and can therefore easily communicate with the 07 KP 93 MODBUS coupler via the serial interfaces COM3 and COM4.

MODBUS® is a master-slave protocol. The master sends a request to the slave and then receives the reply from the slave.

Description of the MODBUS® protocol:

Supported standard	EIA RS-232 / RS-485
Use of the interfaces COM3 and COM4	master or slave
If the interface is a master, it can communicate with	max. 1 slave via the RS-232 interface or max. 31 slaves with RS-485 interface
Protocol	MODBUS® (master/slave)
Data transmission control	CRC 16
Data transmission speed	up to 9600 baud
Maximum length	on RS485: 1200 m with 9600 baud

The MODBUS® frames transmitted by the master contain the following information:

- the MODBUS® address of the interrogated slave (1 byte)
- the function code, defining the master request (1 byte)
- the data to be exchanged (N bytes)
- the CRC16 control code (2 bytes)

Only the following MODBUS® operation codes may be processed by the 07 KT 94 basic unit:

Function codes (hex)	Description
01 or 02	Read n bits
03 or 04	Read n words
05	Write a bit
06	Write a word
0F	Write n bits
10	Write n words

1.2 MODBUS operating modes of the interfaces COM3 and COM4:

The operating mode of the interfaces COM3 and COM4 has to be configured with the CEs MOD_INI1 or MOD_INI2.

a) MODBUS master

The message interchange with the slave(s) is handled by the CE MOD_MAS1 or MOD_MAS2. The CE sends the MODBUS request message to the slave via COM3/COM4 and receives the MODBUS reply from the slave via the interface.

The following has to be used:

- one MOD_MAS1/2 CE for bit operations
- one MOD_MAS1/2 CE for word operations and
- one MOD_MAS1/2 CE for double word operations

b) MODBUS slave

Configuration with the CE MOD_INI1 or MOD_INI2.

The interfaces are unchangeable set to **8 data bits, 1 stop bit, no parity**. The baud rate can be set to 1200, 2400, 4800 or 9600.

Possible configurations of the interfaces COM3/COM4:

- 2 x slave
- 1 x master, 1 x slave

1.3 MODBUS messages

The sending and receiving messages listed below are not visible in the PLC. However, if necessary, they can be made visible on the data line between master and slave with a serial data analyzer.

The number of user data depends on the features of the master **and** of the slave.

In the following examples the slave is a SST MODBUS device. If other devices are used, features can differ.

FCT 1 or 2: Read n bits

n = 1...96

Request

Slave number	Function code	Address		No. of bits		CRC	
		High	Low	High	Low	High	Low

Reply

Slave number	Function code	No. of bytes	...Data...	CRC	
				High	Low

Example: Master reads M 01,04 = 0; M 01,05 = 1; M 01,06 = 0 from the slave 1
 Source address in the slave M01,04: 2014_H = 8212_D
 The read data are stored in the master starting with M 10,01 (target address).

MODBUS request of the master

Slave number	Function code	Address		No. of bits		CRC	
		High	Low	High	Low	High	Low
01	01	20	14	00	03	37	CF

MODBUS reply of the slave

Slave number	Function code	No. of bytes	Data	CRC	
				High	Low
01	01	01	02	D0	49

Parametrization of the inputs of the MOD_MAS1/2 CE

FREI	COM	SLAV	FCT	ADDR	NB	DATA
0 → 1	2	1	1	8212	3	M 10,01

FCT 3 or 4: Read n words

n = 1...96

Request

Slave number	Function code	Address		No. of words		CRC	
		High	Low	High	Low	High	Low

Reply

Slave number	Function code	No. of bytes	...Data...	CRC	
				High	Low

Example: Master reads MW 00,04 = 4; MW 00,05 = 5; MW 00,06 = 6 from the slave 1
 Source address in the slave MW 00,04: 2004_H = 8196_D
 The read data are stored in the master starting with MW 10,01 (target address).

MODBUS request of the master

Slave number	Function code	Address		No. of words		CRC	
		High	Low	High	Low	High	Low
01	03	20	04	00	03	4F	CA

MODBUS reply of the slave

Slave number	Function code	No. of bytes	Data 1		Data 2		Data 3		CRC	
			High	Low	High	Low	High	Low	High	Low
01	03	06	00	04	00	05	00	06	40	B6

Parametrization of the inputs of the MOD_MAS1/2 CE

FREI	COM	SLAV	FCT	ADDR	NB	DATA
0 → 1	2	1	3	8196	3	MW 10,01

FCT 3 or 4: Read n double words

The function code "Read double words" is not defined in the MODBUS/RTV standard. Therefore the combination of the double word from Low Word and High Word (manufacturer-specific).

n = 1...48

Request

Slave number	Function code	Address		No. of words		CRC	
		High	Low	High	Low	High	Low

Reply

Slave number	Function code	No. of bytes	...Data...		CRC	
			High	Low	High	Low

Example: Master reads MD 00,02 = 32; MD 00,03 = 80000 from the slave 1
 Source address MD 00,02: $4002_H = 16386_D$
 The read data are stored in the master starting with MD 00,00 (target address).

MODBUS request of the master

Slave number	Function code	Address		No. of words		CRC	
		High	Low	High	Low	High	Low
01	03	40	02	00	04	F0	09

MODBUS reply of the slave

Slave number	Function code	No. of Bytes	Data 1		Data 2		Data 3		Data 4		CRC	
			High	Low	High	Low	High	Low	High	Low	High	Low
01	03	08	00	00	00	20	00	01	38	80	57	B0

Parametrization of the inputs of the MOD_MAS1/2 CE

NB = Number of MD * 2

FREI	COM	SLAV	FCT	ADDR	NB	DATA
0 → 1	2	1	3	16386	4	MD 00,00

FCT 5: Write 1 bit

n = 1

Data: Bit = 0: 00 00

Bit = 1: FF 00

Request

Slave number	Function code	Address		Data		CRC	
		High	Low	High	Low	High	Low

Reply

Slave number	Function code	Address		Data		CRC	
		High	Low	High	Low	High	Low

Example: Master writes M 01,07 = 1 in the slave 1
 Source address in the master: M10,01 = 1
 Target address in the slave: M 01,07 = 2017_H = 8215_D

MODBUS request of the master

Slave number	Function code	Address		Data		CRC	
		High	Low	High	Low	High	Low
01	05	20	17	FF	00	37	FE

MODBUS reply of the slave (reflection)

Slave number	Function code	Address		Data		CRC	
		High	Low	High	Low	High	Low
01	05	20	17	FF	00	37	FE

Parametrization of the inputs of the MOD_MAS1/2 CE

FREI	COM	SLAV	FCT	ADDR	NB	DATA
0 → 1	2	1	5	8215	1	M 10,01

FCT 6: Write 1 word

n = 1

Request

Slave number	Function code	Address		Data		CRC	
		High	Low	High	Low	High	Low

Reply

Slave number	Function code	Address		Data		CRC	
		High	Low	High	Low	High	Low

Example: Master writes to MW 00,07 in the slave 1 the value of 7
 Source address in the master: MW 10,01 = 7
 Target address in the slave: MW 00,07 = 7
 2007_H = 8199_D

MODBUS request of the master

Slave number	Function code	Address		Data		CRC	
		High	Low	High	Low	High	Low
01	06	20	07	00	07	72	09

MODBUS reply of the slave (reflection)

Slave number	Function code	Address		Data		CRC	
		High	Low	High	Low	High	Low
01	06	20	07	00	07	72	09

Parametrization of the inputs of the MOD_MAS1/2 CE

NB = Number of MD * 2

FREI	COM	SLAV	FCT	ADDR	NB	DATA
0 → 1	2	1	6	8199	1	MW 10,01

FCT 15: Write n bits

n = 1...192 (if 07 KT 94 is MODBUS slave)

Request

Slave number	Function code	Address		No. of bits		No. of bytes	...Data...	CRC	
		High	Low	High	Low			High	Low

Reply

Slave number	Function code	Address		No. of bits		CRC	
		High	Low	High	Low	High	Low

Example: Master writes the bit pattern M 01,01 = 1, M 01,02 = 0, M 01,03 = 1 to the slave 1
 Source address in the master: M 01,01 = 1, M 01,02 = 0, M 01,03 = 1
 Target address in the slave: 2011_H = 8209_D

MODBUS request of the master

Slave number	Function code	Address		No. of bits		No. of bytes	Data	CRC	
		High	Low	High	Low			High	Low
01	0F	20	11	00	03		05	B4	37

MODBUS reply of the slave

Slave number	Function code	Address		No. of bits		CRC	
		High	Low	High	Low	High	Low
01	0F	20	11	00	03	4E	0F

Parametrization of the inputs of the MOD_MAS1/2 CE

FREI	COM	SLAV	FCT	ADDR	NB	DATA
0 → 1	2	1	15	8209	3	M 01,01...

FCT 16: Write n words

n = 1...96 (if 07 KT 94 is MODBUS slave)

Request

Slave number	Function code	Address		No. of words		No. of bytes	...Data...		CRC	
		High	Low	High	Low		High	Low	High	Low

Reply

Slave number	Function code	Address		No. of bits		CRC	
		High	Low	High	Low	High	Low

Example: Master writes the values of 1,2,3 to MW 00,01, MW 00,02, MW 00,03 in the slave 1
 Source address in the master: MW 01,01 = 1, MW 01,02 = 2, MW 01,03 = 3
 Target address in the slave : $2001_H = 8193_D$

MODBUS request of the master

Slave number	Function code	Address		No. of words		No. of bytes	Data 1		Data 2		Data 3		CRC	
		High	Low	High	Low		High	Low	High	Low	High	Low	High	Low
01	10	20	01	00	03	06	00	01	00	02	00	03	C0	84

MODBUS reply of the slave

Slave number	Function code	Address		No. of words		CRC	
		High	Low	High	Low	High	Low
01	10	20	01	00	03	DA	08

Parametrization of the inputs of the MOD_MAS1/2 CE

FREI	COM	SLAV	FCT	ADDR	NB	DATA
0 → 1	2	1	16	8193	3	MW 01,01

FCT 16: Write n double words

The function code "Write double words" is not defined in the MODBUS/RTV standard. Therefore the combination of the double word from Low Word and High Word (manufacturer-specific).

n = 1...48

Request

Slave number	Function code	Address		No. of words		No. of bytes	...Data...		CRC	
		High	Low	High	Low		High	Low	High	Low

Reply

Slave number	Function code	Address		No. of bits		CRC	
		High	Low	High	Low	High	Low

Example: Master writes the values of 18 and 65561 to MD 00,00 and MD 00,01 in the slave 1
 Source address in the master: MD 00,00 = 18, MD 00,01 = 65561
 Target address in the slave: $4000_H = 16384_D$

MODBUS request of the master

Slave No.	Func. code	Address		No. of words		No. of bytes	Data 1		Data 2		Data 3		Data 4		CRC	
		High	Low	High	Low		High	Low	High	Low	High	Low	High	Low		
01	10	40	00	00	04	08	00	00	00	12	00	01	00	19	60	B3

MODBUS reply of the slave

Slave number	Function code	Address		No. of words		CRC	
		High	Low	High	Low	High	Low
01	10	40	00	00	04	D4	0A

Parametrization of the inputs of the MOD_MAS1/2 CE

NB = Number of MD * 2

FREI	COM	SLAV	FCT	ADDR	NB	DATA
0 → 1	2	1	16	16384	4	MD 00,00

Error codes

Send:

SLAVE	FCT v 80H	ERR	CRCL	CRCH
-------	-----------	-----	------	------

Error code 0 = No error is present

Error code 1 = Function is not supported by the slave

Error code 2 = Address error, slave does not have the required data at the given address

Error code 3 = Data error

Error code 9 = Timeout error, slave does not respond within the timeout period

Error code 10 = Checksum error

Error code 16 = Initialization error (interface is not initialized as a master or coupler is initialized by another module)

Error code 17 = Parameter has an error

Example: Address error

Received after reading n words (code 03_H):

01 83 02 C0 C0

with 83_H = 80_H + 03_H

2 Connection elements

The following connection elements are provided with the diskette in volume 1 of this binder. The CEs must be read-in into the 907 PC 331 library.

- MOD_INI1 Initialization of the MODBUS master mode or slave mode (07 KP 93 at 07 KT 92 / 07 KT 93)
- MOD_INI2 Initialization of the MODBUS master mode or slave mode (07 KP 93 at 07 KT 94)
- MOD_MAS1 Realization of the MODBUS master function (07 KP 93 at 07 KT 92 / 07 KT 93)
- MOD_MAS2 Realization of the MODBUS master function (07 KP 93 at 07 KT 94)

The description is on the following pages.

MOD_INI1 Initialization of the MODBUS master mode or slave mode (07 KP 93 at 07 KT **92** / 07 KT **93**)

MOD_INI2 Initialization of the MODBUS master mode or slave mode (07 KP 93 at 07 KT **94**)

The function block MOD_INI1/2 initializes the MODBUS coupler to the operating mode **master** or **slave**.

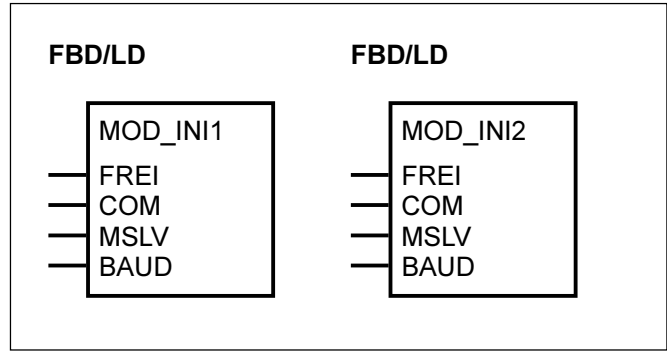

Parameters

FREI	BINARY	A, E, S, M, K	Enable for block processing
COM	WORD	KW	Interface identifier (3 or 4)
MSLV	WORD	KW	0 = Master, 1...254 = Slave address
BAUD	WORD	KW	Baud rate (1200, 2400, 4800, 9600)

CE data

Runtime:
 Basic runtime:
 Additional runtime: ---
 Updating of the outputs: ---
 Number of historical values: none
 Available as of:

Description

The function block MOD_INI1 (MOD_INI2) is processed with a signal 1 at the FREI input.

The CE then initializes the serial interface of the MODBUS coupler defined at the COM input.

The CE MOD_INI1 (MOD_INI2) may be called in the slave operating mode for both COM3 and COM 4, but in the master mode only for one of the interfaces COM 3 or COM4.

The inputs can neither be doubled nor inverted.

FREI BINARY

With a signal 1 at the FREI input the CE is processed.

COM WORD

The number of the interface to be initialized is defined at the COM input.

MSLV WORD

With a 0 at the MSLV input, the MODBUS coupler is initialized as a master. With a number different from 0, the coupler is initialized as a slave with the station address given in MSLV.

BAUD WORD

Setting the baud rate. If a baud rate is specified different from 1200, 2400, 4800 or 9600, 9600 is set.

MOD_MAS1 Realization of the MODBUS master function (07 KP 93 at 07 KT 92 / 07 KT 93)

MOD_MAS2 Realization of the MODBUS master function (07 KP 93 at 07 KT 94)

Dependent on the transaction mode (M, MW or MD) a separate CE has to be used.

The function block is triggered with a 0→1 edge at the FREI input.

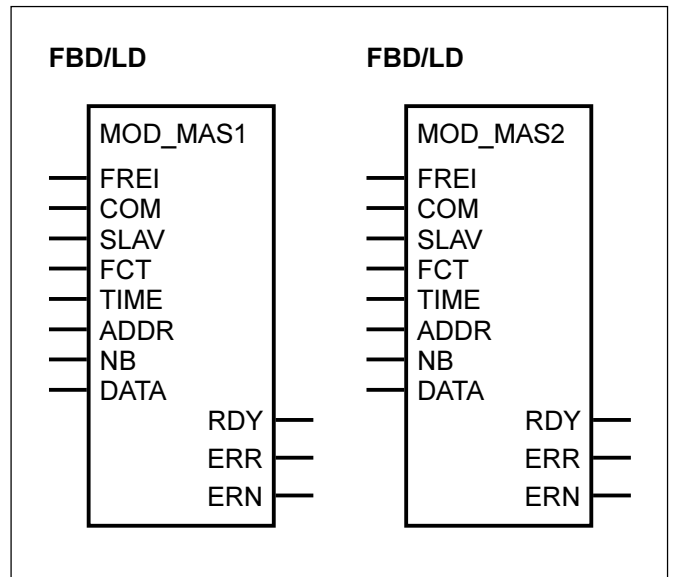

Parameters

FREI	BINARY	M	Enable for block processing
COM	WORD	KW	Interface identifier (3 or 4)
SLAV	WORD	MW, KW	Slave number (1...254)
FCT	WORD	MW, KW	Function number
TIME	WORD	MW, KW	Timeout in ms
ADDR	WORD	MW, KW	Register address in the slave
NB	WORD	MW, KW	Number of data for read/write operations
DATA	WORD DOUBLE WORD	AW, EW, MW, KW MD, KD	The first value of a data field, from which data is written to the slave (write operation) or to which data is stored after reading from the slave (read operation).
RDY	BIN	M	Ready
ERR	BIN	M	Communication error ERR = 0: Communication without error ERR = 1: Communication with error
ERN	WORD	AW, MW	Error number

Description

FREI BINARY

A 0→1 edge at the FREI input starts a master request. If several MODMASTK CEs are used, it has to be made sure that only one of them is enabled at the FREI input at the same time.

COM WORD

The number of the selected COM interface is assigned to the COM input. This number is 3 or 4.

TIME WORD

Timeout in ms. If no response is received from the slave within the period defined at the TIME input, ERR = 1 and ERN = 9 is generated (for the duration of one PLC cycle, see example program).

ADDR WORD

Register address in the slave.

The access to AC31 operands in the slave mode is defined by the following MODBUS cross reference list.

Complete cross reference list

MODBUS address hexadecimal	Operand identifier	
0000	E 00,00	Binary inputs
:	:	
03FF	E 63,15	
1000	A 00,00	Binary outputs
:	:	
13FF	A 63,15	
2000	M 00,00	Binary flags
:	:	
2FFF	M 255,15	
3000	S 00,00	Step chains
:	:	
30FF	S 15,15	
0000	EW 00,00	Word inputs
:	:	
007F	EW 07,15	
1000	AW 00,00	Word outputs
:	:	
107F	AW 07,15	
2000	MW 00,00	Word flags
:	:	
2FFF	MW 255,15	
3000	KW 00,00	Word constants
:	:	
327F	KW 39,15	
4000	MD 00,00	Double word flags
:	:	
41FF	MD 31,15	
5000	KD 00,00	Double word constants
:	:	
507F	KD 07,15	

NB WORD

Number of data which are written to the slave or read from it.

ERR BIN

The ERR output shows errors occurred during processing the MODMASTK CE.

ERN WORD

- 0: No error occurred
- 1: Function is not supported by the slave
- 2: Address error, slave does not have the required data at the given address
- 3: Data error
- 9: Timeout error, slave does not respond within the timeout period
- 10: Checksum error
- 16: Initialization error (interface is not initialized as a master or coupler is occupied by another module)
- 17: Parameter with error

Controlling the inputs and outputs of the CE

The FREI input and the outputs RDY (ready), ERR (error) and ERN (error number) have to be considered together.

FREI: 0→1 edge triggers the task

RDY = 1: MODBUS master is ready for the task

RDY = 0: MODBUS master is busy

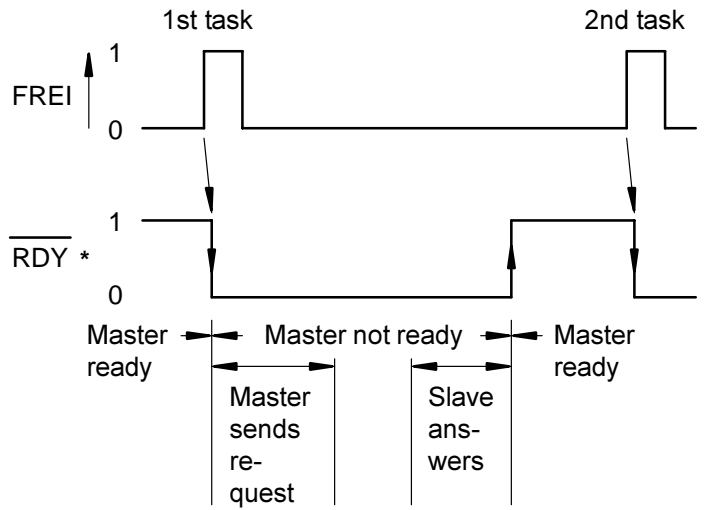

* RDY = M 15,01 (ready inverted)
see the following example

Example program:
07 KP 93 (master) + 07 KT 94 ↔ 07 KT 94 (slave)

Task: Read bits M 01,04, M 01,05 and M 01,06 in the slave 1 (07 KT 94) with maximum frequency (high polling). The data are stored in the master in M 15,00, M 15,01 and M 15,02.

PLC program

INITIALIZATION

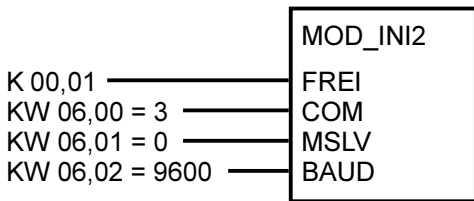

Step chain written against the cycle (head first)

REPLY ARRIVED → M 15,01 = 1

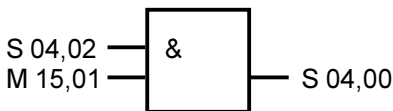

COM2 SENDS REQUEST (M 15,01 = 0) → FREI = 0

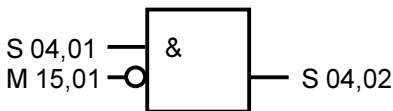

COM3 READY (M 15,01 = 1) → FREI = 1

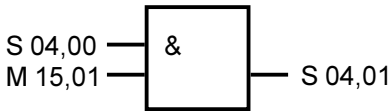

MODBUS master CE

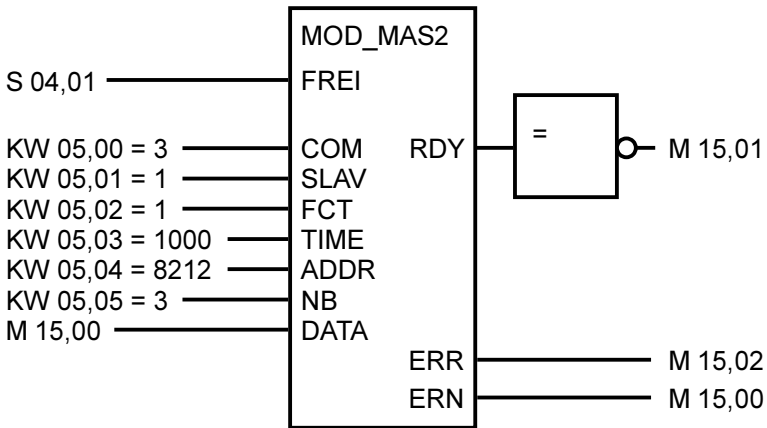

Store ERN: The occurred error number is stored in MW 15,01

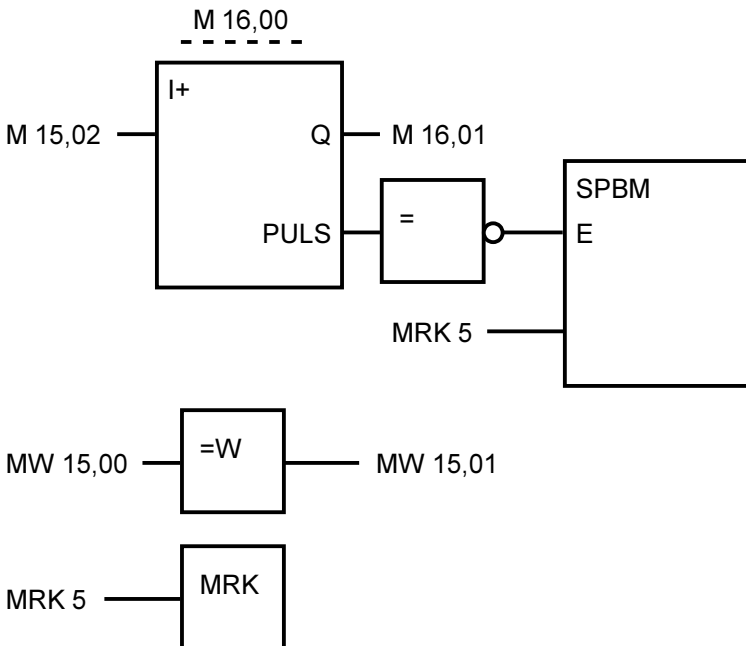

Parametrization for several MODBUS tasks: Use **one** separate CE for M, MW, MD and perform the control from step chains interlocked to each other.

A detailed example program can be requested from our helpline.



Printed on chlorine-free bleached paper

ABB Schalt- und Steuerungstechnik GmbH
Eppelheimer Straße 82 Postfach 10 50 09
D-69123 Heidelberg D-69040 Heidelberg

Telephone +49 6221 777-0
Telefax +49 6221 777-111
E-Mail desst.help@de.abb.com
Internet <http://www.abb-sst.de>

Printed in the Federal Republic of Germany (07.99)