

# ABB Procontic Programming System

907 KP 95  
CE definitions for the  
communication module 07 KP 95

Software Registration Form / Individual License  
General License Conditions for the Supply of  
Computer Software upon Payment of a Non-  
Recurring License Fee (ALCN) / Floppy Disks **1**

---

Hardware 07 KP 95 **2**

---

Order No.: GJP5 2066 00 R0102

Installation **3**

---

Examples **4**

---

**5**

---

**6**

---

Connection element library **7**

---

**8**

---

**9**

---

24 mm

**ABB Procontic Programming System**   **ABB Procontic Programming System**   **ABB Procontic Programming System**   **ABB Procontic Programming System**   **ABB Procontic Programming System**   **ABB Procontic Programming System**

**907 KP 95 CS31**   **907 KP 95 CS31**   **907 KP 95 CS31**   **907 KP 95 CS31**   **907 KP 95 CS31**   **907 KP 95 CS31**

**GJP5 2066 00 GJP5 2066 00 GJP5 2066 00 GJP5 2066 00 GJP5 2066 00 GJP5 2066 00**

59 mm

**ABB Procontic Programming System**   **ABB Procontic Programming System**   **ABB Procontic Programming System**   **ABB Procontic Programming System**   **ABB Procontic Programming System**   **ABB Procontic Programming System**

**907 KP 95 CS31**   **907 KP 95 CS31**   **907 KP 95 CS31**   **907 KP 95 CS31**   **907 KP 95 CS31**   **907 KP 95 CS31**

**GJP5 2066 00 GJP5 2066 00 GJP5 2066 00 GJP5 2066 00 GJP5 2066 00 GJP5 2066 00**

**ABB Procontic Programming System**   **ABB Procontic Programming System**   **ABB Procontic Programming System**   **ABB Procontic Programming System**   **ABB Procontic Programming System**   **ABB Procontic Programming System**

**907 KP 95 CS31**   **907 KP 95 CS31**   **907 KP 95 CS31**   **907 KP 95 CS31**   **907 KP 95 CS31**   **907 KP 95 CS31**

**GJP5 2066 00 GJP5 2066 00 GJP5 2066 00 GJP5 2066 00 GJP5 2066 00 GJP5 2066 00**

**ABB Procontic Programming System**   **ABB Procontic Programming System**   **ABB Procontic Programming System**   **ABB Procontic Programming System**   **ABB Procontic Programming System**   **ABB Procontic Programming System**

**907 KP 95 CS31**   **907 KP 95 CS31**   **907 KP 95 CS31**   **907 KP 95 CS31**   **907 KP 95 CS31**   **907 KP 95 CS31**

**GJP5 2066 00 GJP5 2066 00 GJP5 2066 00 GJP5 2066 00 GJP5 2066 00 GJP5 2066 00**

## Notes on completing the software registration forms

---

***Please complete the software registration forms in full and using a typewriter or in block capitals. Please return the "Double" to ABB. Do not forget to sign the software registration forms!***

The software registration form should contain the following information in order to prevent difficulties or delays in provision of software updates for you:

### **Licensee**

Name or company:	Full company name
Department/Contact person/Phone:	Name of department, name and telephone number of the contact person
Address:	Street/road and number or P.O.Box, country code, postal code, town/city
Date of delivery: (as defined in ALCN 4.1)	Already completed (if you do not have this information, please enter the date of receipt)
Name/legally binding signature:	Name in block capitals and signature

### **Customer Hardware (PC)**

Hardware manufacturer:	Manufacturer of the PC used (e.g. Compaq)
Type:	Precise type designation of the PC used (e.g. 80486DX)

### **Software Product**

Product name:	Designation of the software (e.g. 907 PC 331; already completed)
Version:	Version number (already completed)
Identification No.:	Identification No. of the software (already completed)
Serial No.:	Diskette creation date (e.g. 12.92 = Dec. 92; already completed)
ABB order No. or ABB office:	ABB order No. or ABB field office which supplied the software (already completed)
New software version should be offered according to ALCN 6.2:	State whether new software versions are to be offered in accordance with ALCN 6.2

# Specification in accordance with Item 5.2 ALCN

---

## General

The programming of the communication processor is carried out in the PLC program with a PC using the programming and test system 907 PC 331.

The programming software 907 KP 95 provides all connection elements necessary for operating the communication processor 07 KP 95:

- AF100
- DSPIN
- DSPOUT
- DWREAL
- REALDW

The communication processor 07 KP 95 allows interfacing of ABB Procontic CS31 to the AF100 (Advant Fieldbus 100). The communication processor 07 KP 95 **needs** additionally a communication interface **CI520** and an appropriate bus modem. The 07 KP 95 contains the carrier board for the CI520 (similar to the Submodule Carrier Board with the Advant Controller 450, but the 07 KP 95 has only one slot for **one** CI520).

## Features of the unit 07 KP 95

The following functions are supported by the 07 KP 95:

- master or slave at the AF100 (function block AF100)
- single-channel or redundant configuration of the AF100 (selectable via the function block AF100)
- transmission of cyclic data using the function blocks DSPIN and DSPOUT (max. 475 DSPs with 8 DATs, max. 250 DSPIN and 249 DSPOUT)
- service data: station, type, version, status
- no event handling
- no time-sync
- no program-load

## Survey of Advant Fieldbus (AF100), 07 KP 95 and ABB Procontic CS31

- The AF100 is a field bus, to which a maximum of 80 AF100 stations (nodes) can be connected. Each station can be a master or a slave. At least one master must be connected to an AF100, several masters are possible.
- The AF100 distinguishes between **process data**, which are transmitted cyclically (Cyclic Data Packages) and **messages** (diagnosis data, events), which are only transmitted if necessary.
- The AF100 can be configured in single-channel mode or redundant. In the redundant configuration, the data are always sent via both busses. The data, however, are only received from one bus. The switch-over to the bus, from which the data is received, is performed automatically by the hardware.
- The transmission medium for the AF100 can be a twisted pair, a coaxial cable or an optical fiber. For the connection between the coupler and the AF100 bus, an appropriate modem must be selected.
- For the transmission of cyclic data on the Advant Controller side, the data base element DSP (Data Set Peripheral) is available. Each DSP can contain up to 8 data elements (DATs) of the types boolean, integer, long integer or real. In the data base element, the following is given: the number of DATs, the transmission interval, the direction (sending or receiving DSP), the identification and the station number.
- Analog to that, on the CS31 side there are the function blocks DSPIN (receiving DSP) and DSPOUT (sending DSP). As a maximum, a number of 475 DSPs with 8 DATs each can be configured. The max. number of function blocks is 250 DSPINs and 249 DSPOUTs.
- For initialization, the function block AF100 is available (station number, master/slave, AF100 bus single/redundant).

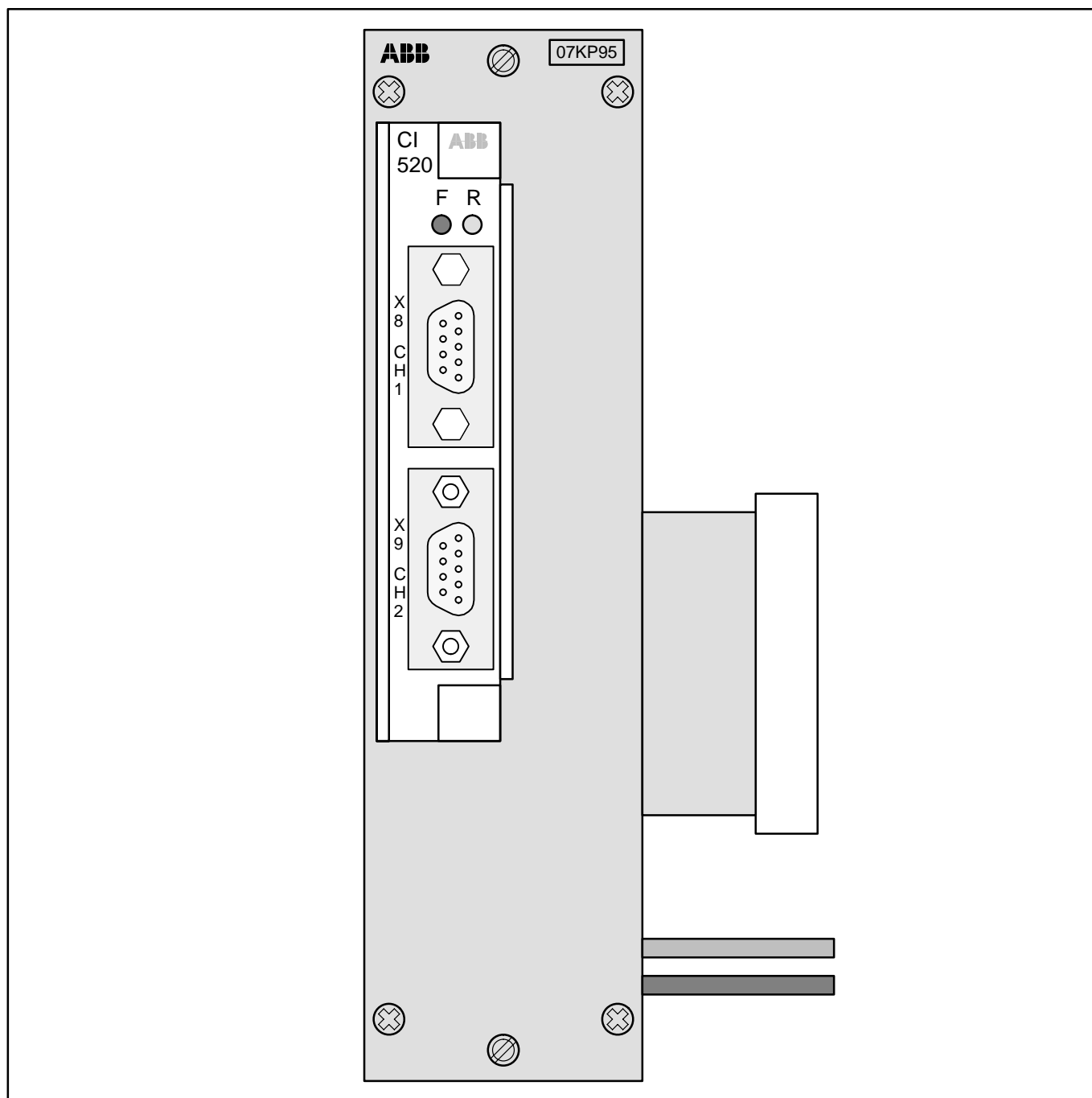

## **Regulations Concerning the Setting up of Installations**

Apart from the basic "Regulations for the Setting up of Power Installations" DIN VDE\* 0100 and for "The Rating of Creepage Distances and Clearances" DIN VDE 0110 Part 1 and Part 2 the regulations "The Equipment of Power Installations with Electrical Components" DIN VDE 0160 in conjunction with DIN VDE 0660 Part 500 have to be taken into due consideration.

Further attention has to be paid to DIN VDE 0113 Part 1 and Part 200 in case of the control of working and processing machines. If operating elements are to be mounted near parts with dangerous contact voltage DIN VDE 0106 Part 100 is additionally relevant.

If the protection against direct contact according to DIN VDE 0160 is required, this has to be ensured by the user (e.g. by incorporating the elements in a switch-gear cabinet). The devices are designed for pollution severity 2 in accordance with DIN VDE 0110 Part 1. If higher pollution is expected, the devices must be installed in appropriate housings.

The user has to guarantee that the devices and the components belonging to them are mounted following these regulations. For operating the machines and installations, other national and international relevant regulations, concerning prevention of accidents and using technical working means, also have to be met.

The ABB Procontic devices are designed according to IEC 1131 Part 2. Meeting this regulation, they are classified in overvoltage category II which is in conformance with DIN VDE 0110 Part 2.

For the direct connection of ABB Procontic devices, which are powered with or coupled to AC line voltages of overvoltage category III, appropriate protection measures corresponding to overvoltage category II according to IEC-Report 664/1980 and DIN VDE 0110 Part 1 are to install.

Equivalent standards:

DIN VDE 0110 Part 1  $\cong$  IEC 664

DIN VDE 0113 Part 1  $\cong$  EN 60204 Part 1

DIN VDE 0660 Part 500  $\cong$  EN 60439-1  $\cong$  IEC 439-1

All rights reserved to change design, size, weight, etc.

\* VDE stands for "Association of German Electrical Engineers".

ABB Schalt- und Steuerungstechnik GmbH Heidelberg

# 1 Communication processor 07 KP 95 R101

## Communication over the Advant Fieldbus 100

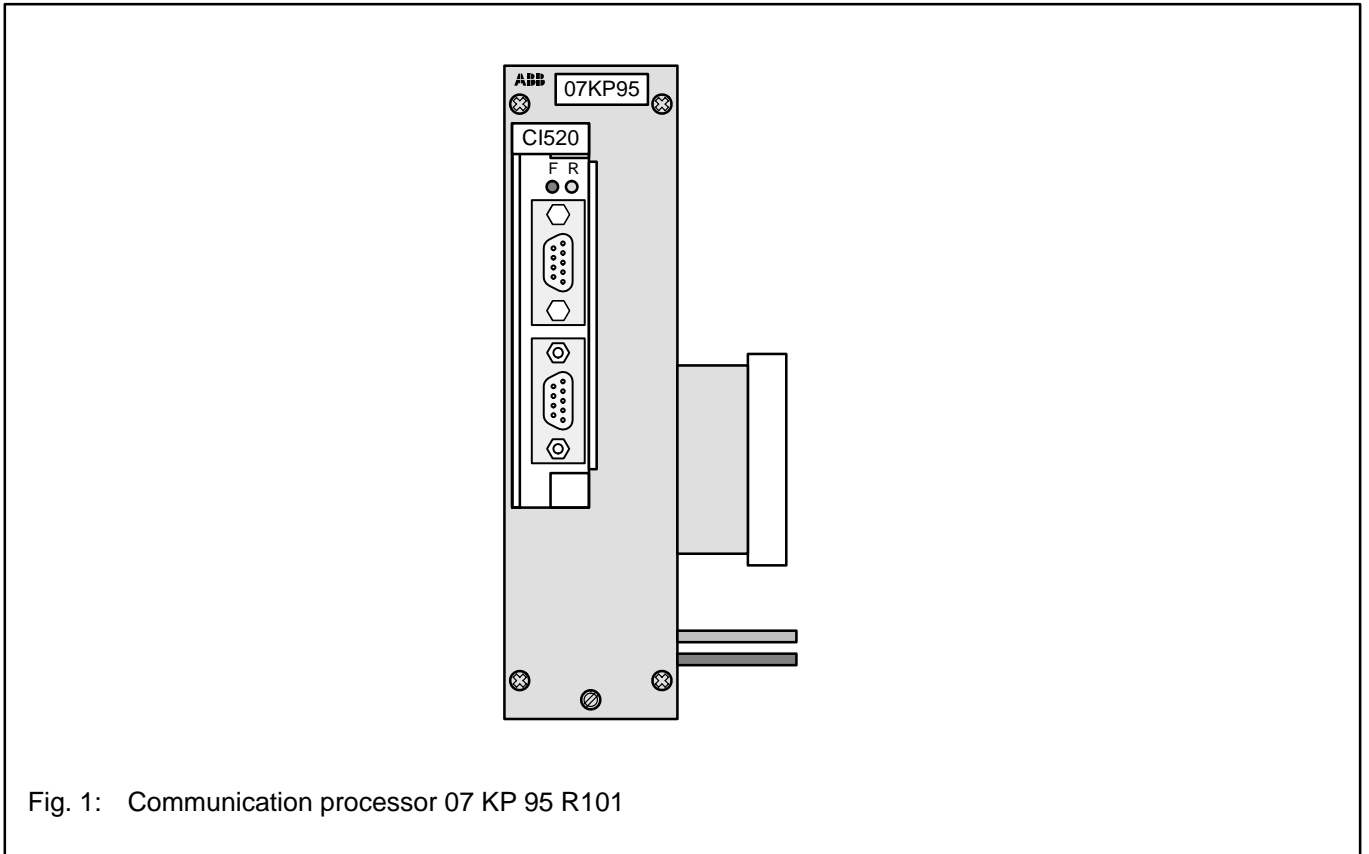

Fig. 1: Communication processor 07 KP 95 R101

### Contents

1.1	Brief description .....	1
1.2	Features of the unit 07 KP 95 .....	1
1.3	Survey of Advant Fieldbus (AF100), 07 KP 95 and ABB Procontic CS31 .....	2
1.4	Structure of the front panel .....	2
1.5	Electrical connection .....	2
1.5.1	Application examples for AF100 coupling with modem, coupler 07 KP 95 and central unit .....	2
1.5.2	Connection of the supply voltage .....	5
1.5.3	Networking interface .....	5
1.5.4	Measures for RFI .....	5
1.7	Technical data .....	6
1.8	Ordering data .....	8

### 1.1 Brief description

The communication processor 07 KP 95 allows interfacing of ABB Procontic CS31 to the AF100 (Advant Fieldbus 100). The communication processor 07 KP 95 **needs** additionally a communication interface **CI520** and an appropriate bus modem. The 07 KP 95 contains the carrier board for the CI520 (similar to the Submodule Carrier Board with the Advant Controller 450, but the 07 KP 95 has only one slot for **one** CI520).

The programming of the communication processor is carried out in the PLC program with a PC using the programming and test system 907 PC 331.

The programming software 907 KP 95 provides all connection elements necessary for operating the communication processor 07 KP 95:

- AF100
- DSPIN
- DSPOUT
- DWREAL
- REALDW

### 1.2 Features of the unit 07 KP 95

The following functions are supported by the 07 KP 95:

- master or slave at the AF100 (function block AF100)
- single-channel or redundant configuration of the AF100 (selectable via the function block AF100)
- transmission of cyclic data using the function blocks DSPIN and DSPOUT (max. 475 DSPs with 8 DATs, max. 250 DSPIN and 249 DSPOUT)
- service data: station, type, version, status
- no event handling
- no time-sync
- no program-load

### 1.3 Survey of Advant Fieldbus (AF100), 07 KP 95 and ABB Procontic CS31

- The AF100 is a field bus, to which a maximum of 80 AF100 stations (nodes) can be connected. Each station can be a master or a slave. At least one master must be connected to an AF100, several masters are possible.
- The AF100 distinguishes between **process data**, which are transmitted cyclically (Cyclic Data Packages) and **messages** (diagnosis data, events), which are only transmitted if necessary.
- The AF100 can be configured in single-channel mode or redundant. In the redundant configuration, the data are always sent via both busses. The data, however, are only received from one bus. The switch-over to the bus, from which the data is received, is performed automatically by the hardware.
- The transmission medium for the AF100 can be a twisted pair, a coaxial cable or an optical fiber. For the connection between the coupler and the AF100 bus, an appropriate modem must be selected.
- For the transmission of cyclic data on the Advant Controller side, the data base element DSP (Data Set Peripheral) is available. Each DSP can contain up to 8 data elements (DATs) of the types boolean, integer, long integer or real. In the data base element, the following is given: the number of DATs, the transmission interval, the direction (sending or receiving DSP), the identification and the station number.
- Analog to that, on the CS31 side there are the function blocks DSPIN (receiving DSP) and DSPOUT (sending DSP). As a maximum, a number of 475 DSPs with 8 DATs each can be configured. The max. number of function blocks is 250 DSPINs and 249 DSPOUTs.
- For initialization, the function block AF100 is available (station number, master/slave, AF100 bus single/redundant).

### 1.4 Structure of the front panel

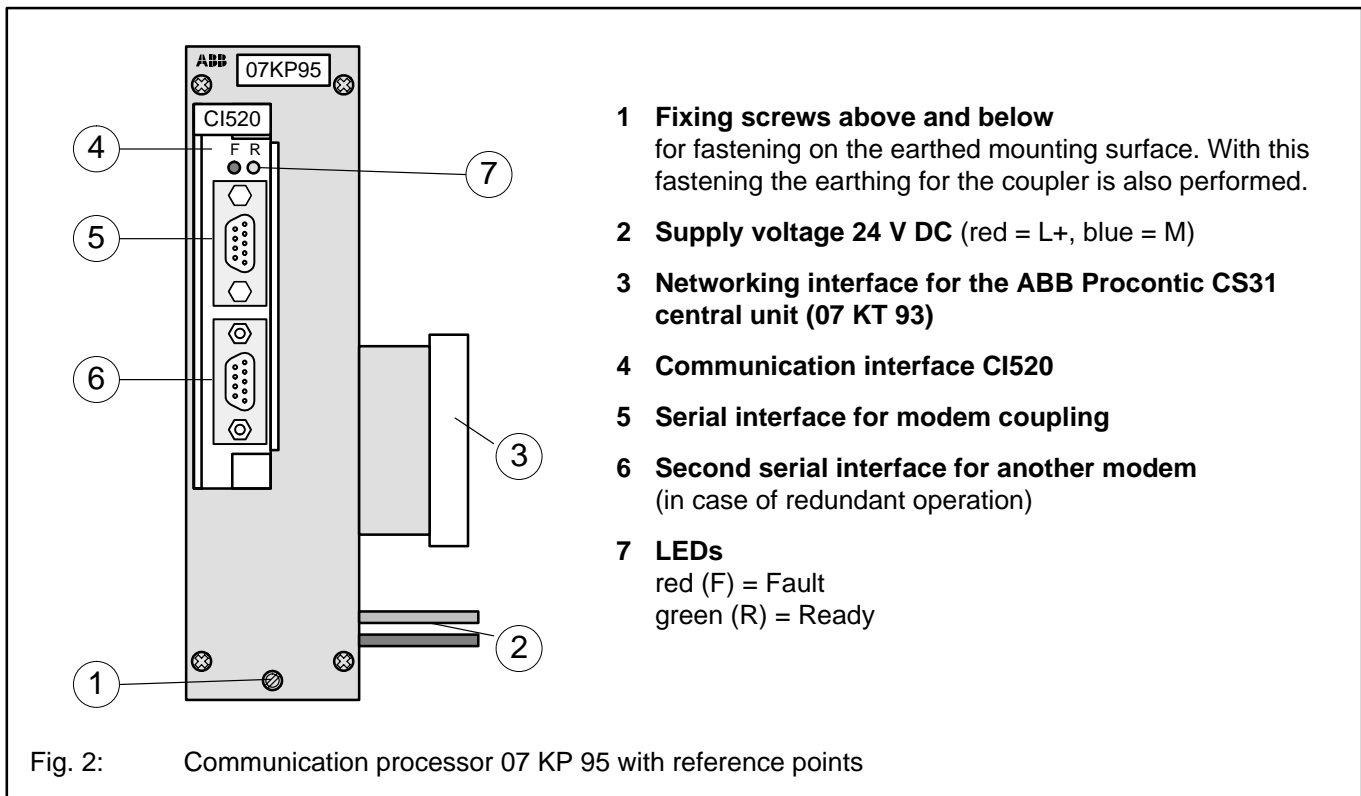

### 1.5 Electrical connection

#### 1.5.1 Application examples for AF100 coupling with modem, coupler 07 KP 95 and central unit

The following figures show two application examples for single-channel and redundant configuration. Attention must be paid to the following in detail:

- The earthing measures
- The connection of the communication processor 07 KP 95 to the modem(s).
- Looping through the supply voltage (24 V DC) from the 07 KT 93 to the 07 KP 95 R101
- Earthing the switch cabinet mains sockets
- Using the AF100 bus with coaxial cable

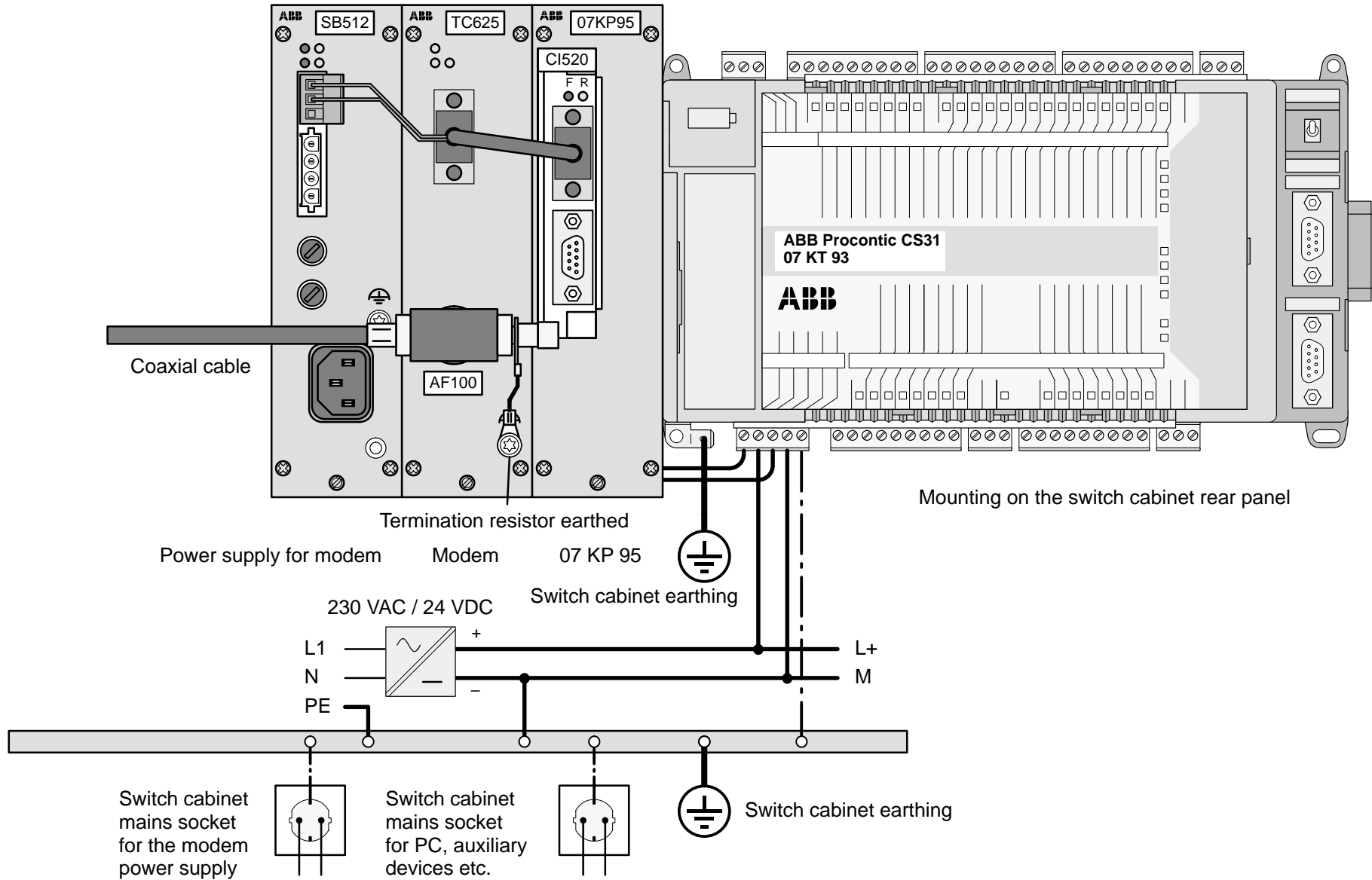
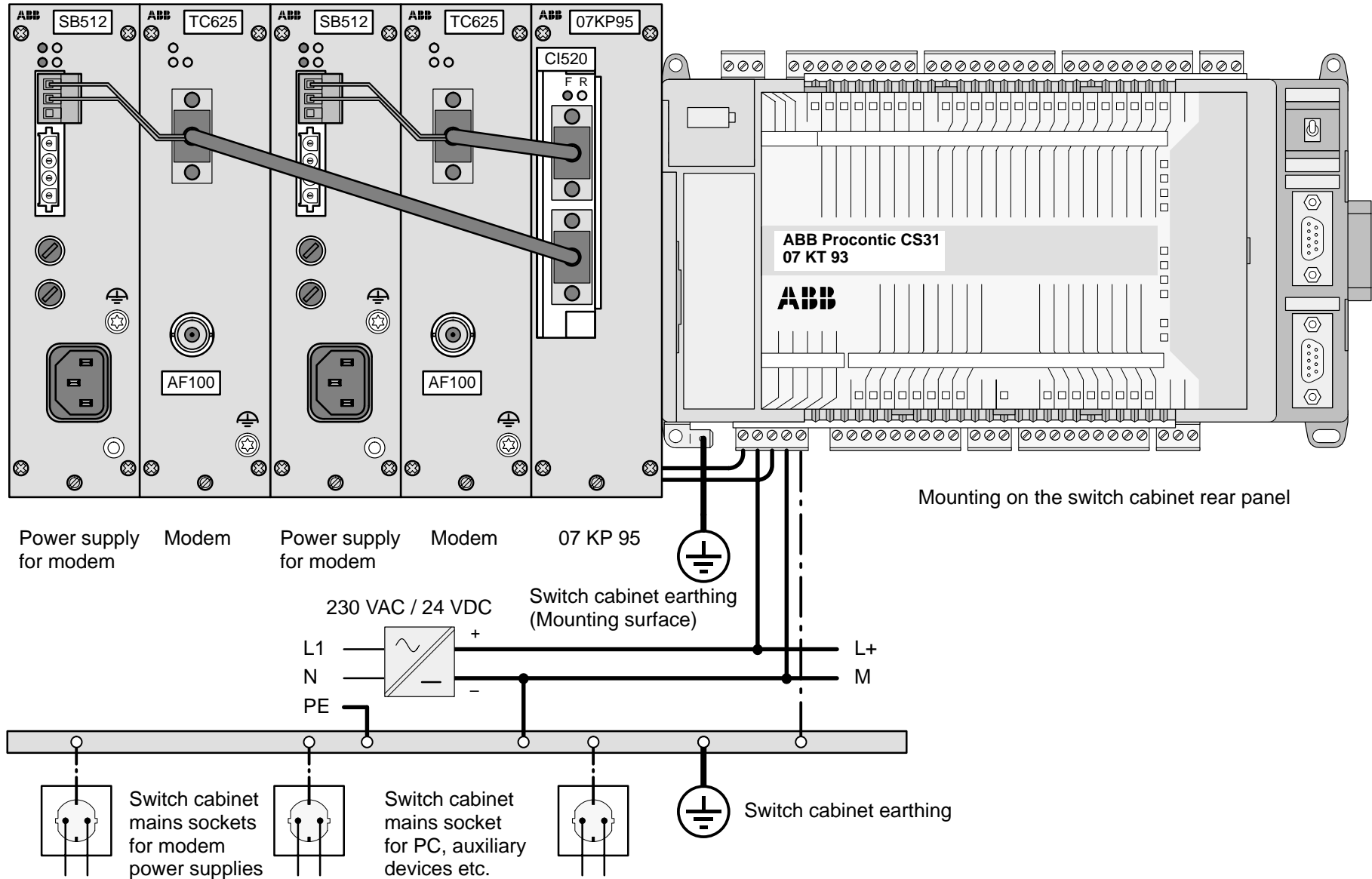

Fig. 3: Application example of an AF100 coupling with modem, coupler and central unit (typical switch cabinet configuration)



Mounting on the switch cabinet rear panel

Power supply for modem

Modem

Power supply for modem

Modem

07 KP 95

230 VAC / 24 VDC

Switch cabinet earthing (Mounting surface)

L1

N

PE

L+

M

Switch cabinet mains sockets for modem power supplies

Switch cabinet mains socket for PC, auxiliary devices etc.

Switch cabinet earthing

Fig. 4: Application example of an AF100 coupling with modems, coupler and central unit, redundant configuration (typical switch cabinet configuration)

### 1.5.2 Connection of the supply voltage 24 V DC

As shown in Fig. 3 and Fig. 4, the supply voltage for the 07 KP 95 is looped through from the CS31 central unit (red wire = L+, blue wire = M).

### 1.5.3 Networking interface

The networking interface, a special parallel interface, allows the 07 KP 95 communication processor to be connected to ABB Procontic CS31 central units 07 KT 93. The housing of the communication processor is connected to the housing of the ABB Procontic central unit by a snap-fit connection. The electrical connection is via a 40-pole ribbon cable with socket connector, soldered onto the 07 KP 95 R101 side.

**Note:** Attachment and disconnection of units on the networking interface may only be performed when all supply voltages are switched off.

### Mounting the communication processor at the networking interface

1. Detach the cover on the central unit (e.g. 07 KT 93) from the networking interface.
2. Plug the socket strip of the 40-pole ribbon cable secured to the 07 KP 95 R101 onto the networking connector of the CS31 central unit.
3. Slide both units together.
4. Slide the replacement cover provided with the 07 KP 95 unit with its cut-out onto the networking interface.

### 1.5.4 Measures for RFI (Radio Frequency Interference)

- Installation in a metallic switch-gear cabinet
- Mains filters

## 1.7 Technical data

In general, the details in Section 1 "System data and system structure" of volume 2 of the system description "ABB Procontic CS31" apply as technical data. Supplementary and deviating data is listed below.

### 1.7.1 General data

Number of parallel interfaces

1 networking interface for connecting to the  
ABB Procontic CS31 central unit

1 interface for communication interface CI520

Note: The communication interface CI520 must be ordered separately and is not supplied together with the 07 KP 95

### 1.7.2 Supply voltage 07 KP 95 R101

Rated supply voltage

24 V DC

Power dissipation

typ. 6 W

max. current consumption

with rated voltage

250 mA

with supply voltage 30 V

200 mA

Protection against reversed terminal connection

yes

### 1.7.5 Mechanical data

Fastening on a mounting surface

by screws, distance 163 mm  
height of mounting surface 180 mm

Width x height x depth

46 x 180 x 170 mm

Weight

1.2 kg

Dimensions for mounting

see following drawing

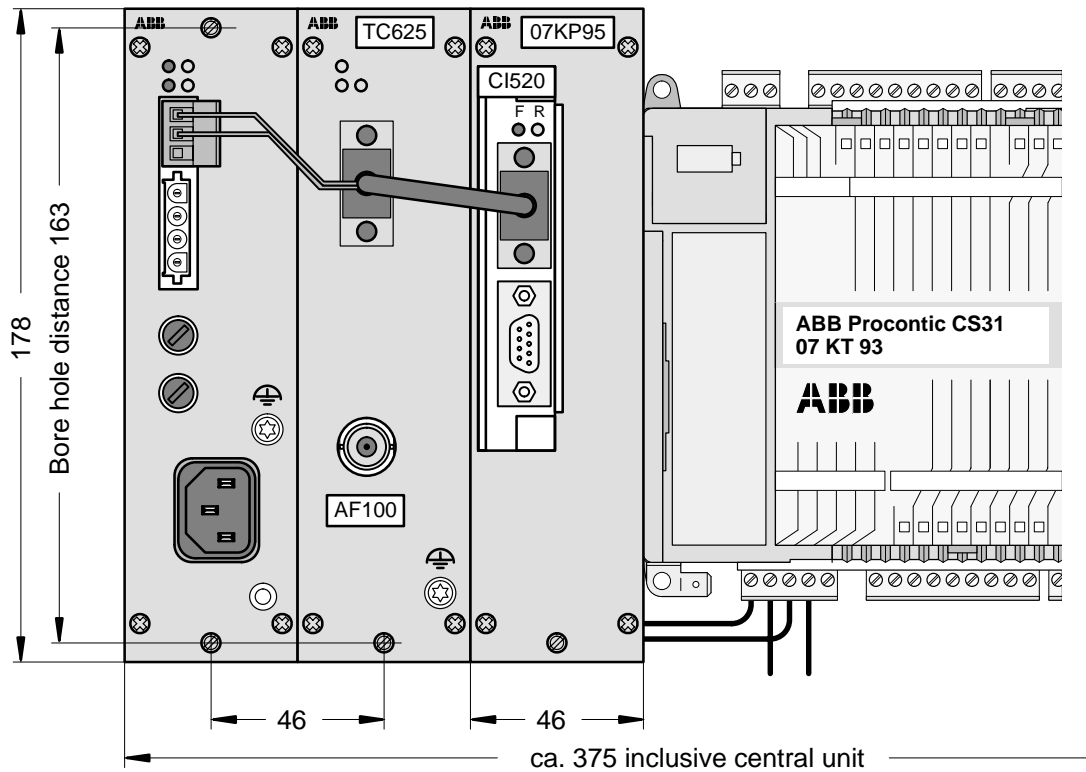

All dimensions in mm.

The device is 170 mm deep without C1520 inserted. The depth is 191 mm with C1520 inserted. There must be enough space for interface connectors and cables.

Fig. 6: Outline dimensions of the communication processor 07 KP 95 R101, front view

### 1.7.6 Mounting hints

Mounting position

fastening on the switch cabinet rear panel

Cooling

The natural convection must not be hindered by cable ducts or other material mounted in the switch cabinet.

## 1.8 Ordering data

Communication processor 07 KP 95 R101

Order No. GJR5 2520 00 R0101

Scope of delivery

Communication processor 07 KP 95 R0101  
Earthing instructions  
Replacement cover for the networking interface

### Further literature

System description ABB Procontic CS31, English

FPTN 4400 04 R2001

Operating manual 07 KR 91 / 07 KT 92 / 07 KT 93, Eng.

GATS 1316 23 R2001

### Software

907 KP 95 R0102, Documentation, CE library

GJP5 2065 00 R0102 (German documentation)  
GJP5 2066 00 R0102 (English documentation)

### Additional components (see also Figures 3 and 4)

CI520 Communication interface

TC625 AF100 modem for coaxial cable (contains interface cable CI520 <-> TC625)

TC512 AF100 modem for twisted pair (contains interface cable CI520 <-> TC512)

SB512 Power supply unit for modem

These components can be ordered under the following address:

ABB Industrietechnik AG  
Abteilung IND / OM  
Dudenstraße 44–46  
D–68167 Mannheim  
Tel.: +49 621 381 1847 (Mr. Bräuler)

### Additional literature

User's Guide Advant Fieldbus 100

Document 3BSE 000 506R0101 (English)

Installation Rules

Document 3BSE 009 178R0001 (English)

Installation

**ABB Procontic CS31**  
Intelligent Decentralized  
Automation System

907 KP 95  
CE definitions for the  
communication processor  
07 KP 95

---



# Contents

---

<b>1</b>	<b>Installation of the CE definitions 907 KP 95</b>	
1.1	Contents of the diskette .....	1-1
1.2	Installation of the CE definitions .....	1-1



# 1 Installation of the CE definitions 907 KP 95

---

Programming of the communication module 07 KP 95 is done via PC with the programming system 907 PC 331.

All connection elements, which are necessary for operation of the 07 KP 95 are delivered on a 3.5" diskette together with this description.

During installation, the write protection of the diskette must not be switched on.

## 1.1 Contents of the diskette

The diskette contains

- CE definitions AF100, DSPIN, DSPOUT, DWREAL and REALDW for 907 PC 331

## 1.2 Installation of the CE definitions

Proceed as follows to install the CE library:

- Select the directory of 907 PC 331 for CS31:

```
C:\>cd\abb-sps\cs31
C:\ABB-SPS\CS31> _
```

- Up to version 04/96 of the software 907 PC 331 R302 the following command must be entered:

```
COPY A:\MPST_KR1.TRS
```

In doing so, the mentioned file will be copied into the directory C:\ABB-SPS\CS31. With later versions of 907 PC 331 the file must not be copied.

- Start 907 PC 331 for CS31:  

```
C:\ABB-SPS\CS31> cs31
```
- Select any project:
- Enter the name of the library into which you wish to put the connection elements AF100, DSPIN, DSPOUT, DWREAL and REALDW as the library name, e.g.: BIB\CS31. Now leave the project data editor with <ESC>. The main menu of 907 PC 331 now appears.
- Select the menu point:  
'Library/Read manufacturer library'. The computer asks you about the path of the block to be read. Delete the statement for the path name and enter the following:  

```
A: 907KP95E
```
- The computer now reads in the library.

The necessary connection elements for the 07 KP 95 are now available in the library "BIB\CS31".



Examples

**ABB Procontic CS31**  
Intelligent Decentralized  
Automation System

907 KP 95  
CE definitions for the  
communication processor  
07 KP 95

---



# Table of Contents

---

<b>1</b>	<b>Examples</b>	
1.1	Communication between AC110 and 07 KT 93 R171 via AF100 .....	1



# 1 Examples for the 07 KP 95

---

## 1.1 Communication between AC110 and 07 KT 93 R171 via AF100

For the transmission of cyclic data on the Advant controller side the data bank element DSP (Data Set Peripheral) is available. Each DSP can contain up to 8 data elements (DATs) of the types boolean, integer, integer long or real. At the data bank element it is defined the number of DATs, the transmission interval, the direction (sending or receiving DSP), the identification and the station number. In the same way, there are on the CS31 side the function blocks DSPIN (receiving DSP) and DSPOUT (sending DSP).

The inputs IDENT and STATION of the DB element DSP (or #ID and #ST of the connection element DSPIN/DSPOUT) define the unambiguous identification of the DSP at the AF100 bus. At each bus, this identification may only be used by **one** DSPOUT block (or sending DSP for the Advant controller), but it can be used by **sev-**

**eral** DSPIN blocks (or receiving DSPs for the Advant controller).

In order to guarantee an error-free communication, the values for IDENT, STATION, CYCLETIM, NO\_BREC, NO\_INT, NO\_INTL and NO\_REAL of the DB element "sending DSP" must be equal to the values for #ID, #ST, #CT, #NB, #NI, #NIL and #NR of the corresponding function block DSPIN. For the same reason, the values for IDENT, STATION, CYCLETIM, NO\_BREC, NO\_INT, NO\_INTL and NO\_REAL of the DB element "receiving DSP" must be equal to the values for #ID, #ST, #CT, #NB, #NI, #NIL and #NR of the corresponding function block DSPOUT. The input SORT\_REF must be on "YES" at the DSPs.

At the DB element CI626, the value at the input BUSNO must be equal to the value of the input BUS at the corresponding DSP. On the CS31 side, the input #BUS of the connection element AF100 has no significance.

## AC110

DB element:

CI626

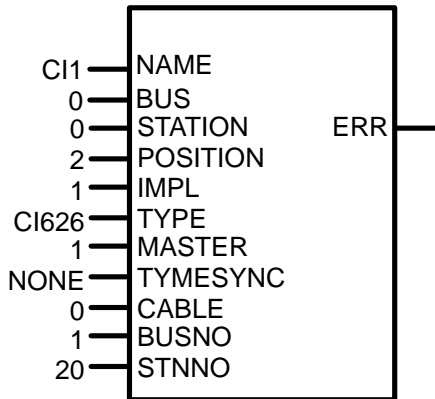

DSP10

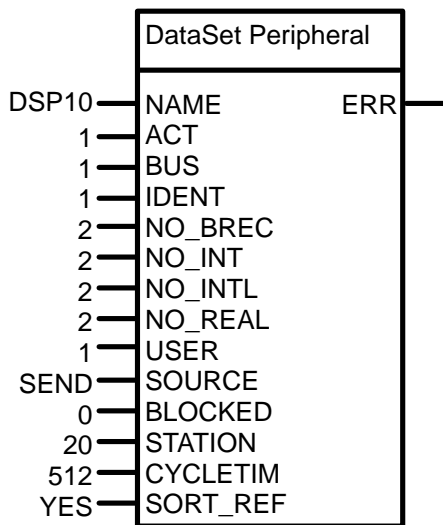

DSP11

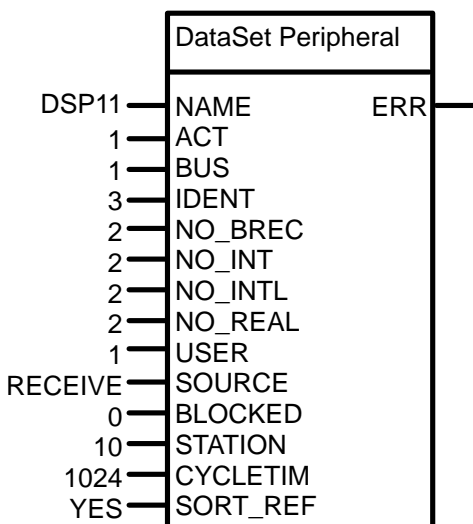

## ABB Procontic CS31

Function block:

K 00,01 = 1

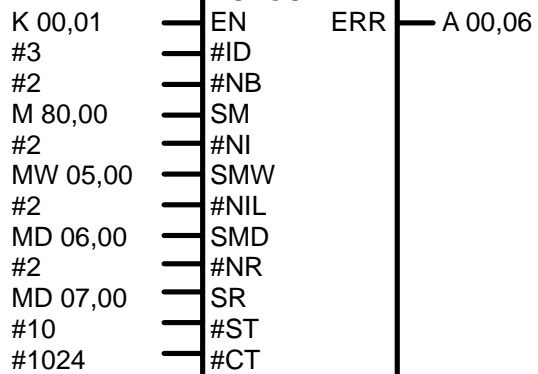
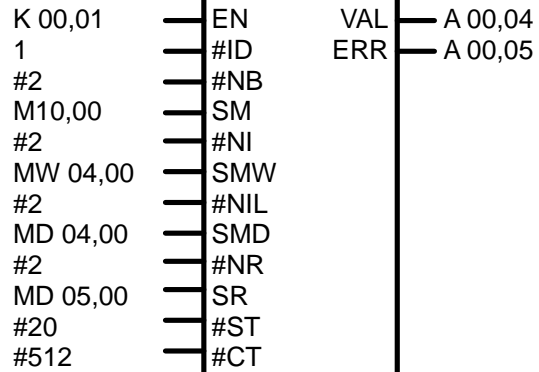
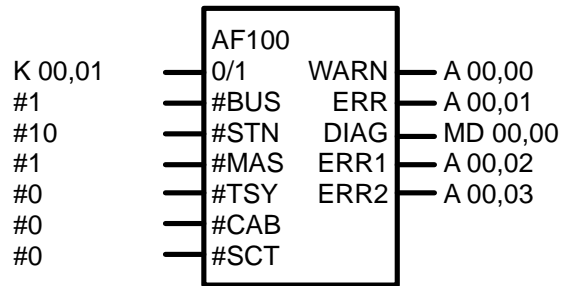

Connection elements

**ABB Procontic CS31**  
Intelligent Decentralized  
Automation System

907 KP 95  
CE definitions for the  
communication processor  
07 KP 95

---

**ABB Schalt-  
und Steuerungstechnik**





# Contents

---

## Connection elements

AF100	Initialization of the AF100 coupler 07 KP 95 .....	3
DSPIN	Read DSP from the AF100 coupler 07 KP 95 .....	5
DSPOUT	Write DSP to the AF100 coupler 07 KP 95 .....	8
DWREAL	Double word to Real conversion .....	11
REALDW	Real to double word conversion .....	12



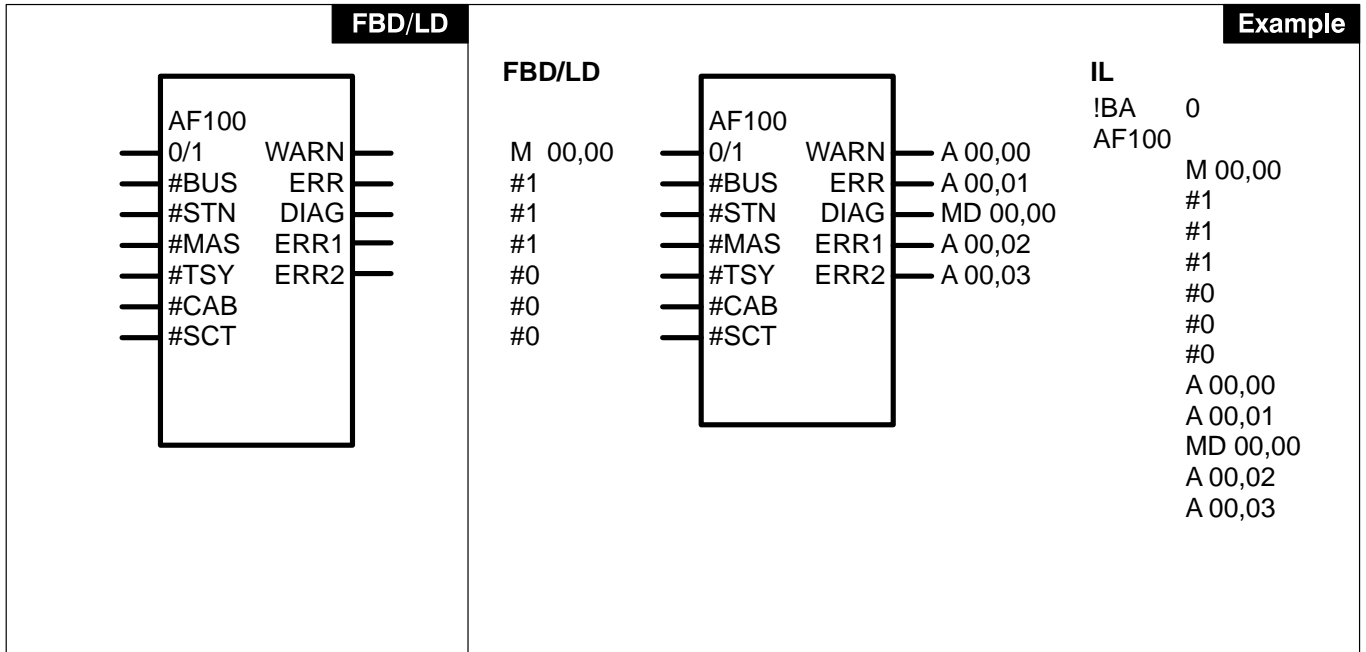

**Parameters**

0/1	BINARY	E, M, A, K, S	Enable block processing
#BUS	DIRECT CONSTANT	#, #H	Bus number; valid values: 1...255 insignificant for CS31
#STN	DIRECT CONSTANT	#, #H	Own station number; valid values: 1...80
#MAS	DIRECT CONSTANT	#, #H	AF100 bus master/slave: #0: bus slave, #1: bus master
#TSY	DIRECT CONSTANT	#, #H	Reserved; valid value: #0
#CAB	DIRECT CONSTANT	#, #H	#0: no redundant AF100 bus (1 cable) #1: redundant AF100 bus (2 cables)
#SCT	DIRECT CONSTANT	#, #H	Reserved; valid value: #0
WARN	BINARY	A, M	Warning (not a fatal error)
ERR	BINARY	A, M	An error has occurred (hardware or configuration)
DIAG	DOUBLE WORD	MD	Diagnosis
ERR1	BINARY	A, M	WARN = 1 and ERR1 = 1: redundant cable 1 failed
ERR2	BINARY	A, M	WARN = 1 and ERR2 = 1: redundant cable 2 failed

**Description**

The function block initializes the AF100 coupler 07 KP 95.

**Important note:**

During program modifications on running programs the AF100 function block must not be deleted, and the inputs of the AF100 function block must not be altered.

**0/1** BINARY  
After an 0/1 edge at the input 0/1 the AF100 coupler is initialized to the relevant values. After initialization, further 0/1 edges are ignored.

**#BUS** DIRECT CONSTANT  
At the input BUS, the number of the AF100 bus is defined. This input has no meaning in connection with CS31. The coupler can contain only 1 CI520. Valid values:  $1 \leq \text{BUS} \leq 255$

**#STN** DIRECT CONSTANT

At the input #STN, the own station number is given.

Valid values:  $1 \leq \#STN \leq 80$

**#MAS** DIRECT CONSTANT

At the input #MAS it is given whether the coupler is a bus master or a bus slave.

Values: #0: bus slave, #1: bus master

**#TSY** DIRECT CONSTANT

The input #TSY is a reserved input.

Valid value: #0

**#CAB** DIRECT CONSTANT

At the input #CAB it is defined, whether the AF100 bus is configured redundant or not.

Values: #0: single-channel, #1: redundant

**#SCT** DIRECT CONSTANT

The input #SCT is a reserved input.

Valid value: #0

**WARN** BINARY

At the output WARN it is indicated, whether a warning has appeared during operation (see DIAG).

**ERR** BINARY

At the output ERR it is indicated, whether an error has appeared during operation (see DIAG).

**DIAG** DOUBLE WORD

At the output DIAG, the diagnosis information is indicated. The output is coded binary. It is possible that several bits are set to 1 in the diagnosis double word (DIAG = 65, i.e. ACT = 1 and CRA = 1 (bit 0 and bit 6)).

Meaning of the bits in the double word:

- DIAG = 1: the coupler is active (ACT);  
if the coupler is not active, WARN is set to 1 (bit 0 of DIAG = 1).
- DIAG = 2: severe error (SE);  
a SE causes ERR = 1  
(bit 1 of DIAG = 1).
- DIAG = 4: hardware error (HWE);  
a HWE causes WARN = 1  
(bit 2 of DIAG = 1).

DIAG = 8: software error (SWE);  
an SWE causes ERR = 1  
(bit 3 of DIAG = 1).

DIAG = 16: peripheral hardware error (PHE);  
a PHE causes WARN = 1  
(bit 4 of DIAG = 1).

DIAG = 32: process errors (PRE);  
a PRE causes WARN = 1  
(bit 5 of DIAG = 1).

DIAG = 64: cable redundancy available (CRA)  
(bit 6 of DIAG = 1).

DIAG = 128: redundant cable 1 failed (RC1);  
an RC1 causes WARN = 1  
(bit 7 of DIAG = 1).

DIAG = 256: redundant cable 2 failed (RC2);  
an RC2 causes WARN = 1  
(bit 8 of DIAG = 1).

DIAG = 512: redundant power A failure (RPA);  
an RPA causes WARN = 1  
(bit 9 of DIAG = 1).

DIAG = 1024: redundant power B failure (RPB);  
an RPB causes WARN = 1  
(bit 10 of DIAG = 1).

DIAG = 16384: general error (GE);  
a GE causes ERR = 1  
(bit 14 of DIAG = 1).

DIAG = -32768: general warning (GW);  
a GW causes WARN = 1  
(bit 15 of DIAG = 1).

**ERR1** BINARY

The output ERR1 indicates, that the redundant cable 1 is defective (WARN = 1 and ERR1 = 1).

**ERR2** BINARY

The output ERR2 indicates, that the redundant cable 2 is defective (WARN = 1 and ERR2 = 1).

The inputs and outputs can neither be doubled nor inverted.

**CE data**

Runtime:

Basic runtime:

Additional runtime:

Updating of the outputs:

Number of historical values:

Available as of:

07 KR 91/07 KT 92/07 KT 93

µs

yes

1 word

ABB Procontic CS31 07 KR 91 R202/R252 index c

07 KT 92 R202/R262 index c

07 KT 93 R101 index f

07 KT 93 R171 index f

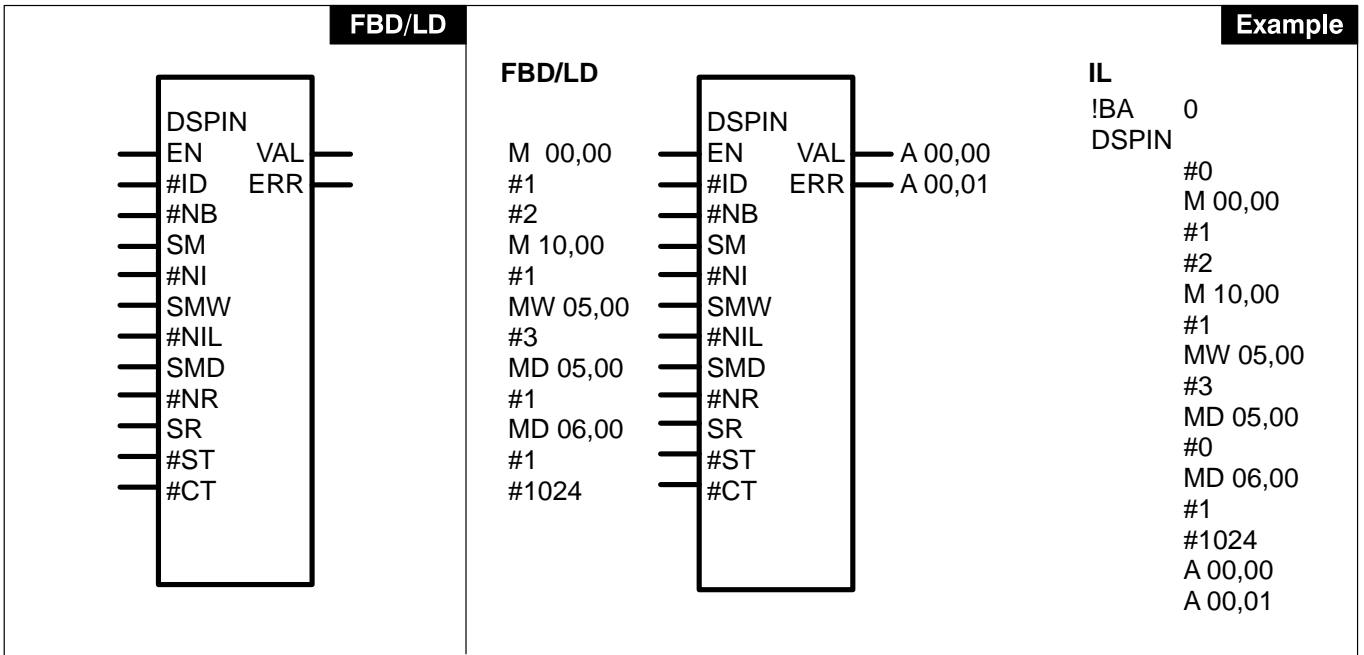

**Parameters**

EN	BINARY	E, M, A, K, S	Enable block processing
#ID	DIRECT CONSTANT	#, #H	Identifier, results together with #ST into the definite identification of the DSP on the AF100 bus; valid values: 1...50 *)
#NB	DIRECT CONSTANT	#, #H	Number of the packed binary values (32 values) of the DSP; valid values: 0...8
SM	BINARY	E, M, A	First flag of the binary range
#NI	DIRECT CONSTANT	#, #H	Number of the word values; valid values: 0...8
SMW	WORD	MW	First word flag of the word range
#NIL	DIRECT CONSTANT	#, #H	Number of the double words of the DSP; valid values: 0...8
SMD	DOUBLE WORD	MD	First double word flag of the double word range
#NR	DIRECT CONSTANT	#, #H	Number of real values; valid values: 0...8
SR	DOUBLE WORD	MD	First double word flag of the real range
		valid values for #NB, #NI, #NIL and #NR: #NB + #NI + #NIL + #NR ≤ 8 and #NB + #NI + #NIL + #NR ≥ 1	
#ST	DIRECT CONSTANT	#, #H	Station address; valid values: 1...80 *) (128 for the status of an other station)
#CT	DIRECT CONSTANT	#, #H	Transmission interval (cycle time) in ms; valid values: 1, 2, 4, 8, 16, 32, 64, 128, 256, 512, 1024, 2048, 4096
VAL	BINARY	A, M	Data are valid
ERR	BINARY	A, M	An error has occurred

\*) With #ST = 128, #ID = station address of the desired station (valid values 1...80), #NB = #NI = #NR = 0 and #NIL = 1 it is possible, to interrogate the status of the station using the address #ID. The status (32 bits) is then available under SMD. The status is coded binary and equals the DIAG output of the AF100 function block.

**Description**

The function block DSPIN reads a DSP (data set peripheral) from the AF100 coupler 07 KP 95 (Advant Fieldbus 100 coupler). An other station sends this DSP over the AF100 bus. The function block DSPIN is similar to the Element Receiving DSP of the Advant controllers.

The inputs #NB, SM through #NR, SR define the composition of the DSP. The inputs #ID and #ST define the definite identification of the DSP on the AF100 bus. For each bus, this identification may be used only by **one** DSPOUT block (or Sending DSP for the Advant controller), but by **several** DSPIN blocks (or Receiving DSPs for the Advant Controllers).

The DSP, which is read by the DSPIN function block, is written by an other station with the DSPOUT function block (or sending DSP element). The values #ID, #ST, #NB, #NI, #NIL, #NR of the DSPIN function block must be equal to the values #ID, #ST, #NB, #NI, #NIL, #NR of the corresponding DSPOUT function block (sending DSP element).

**Important note:**

During program modifications on running programs the DSPIN function block must neither be deleted nor added, and the inputs of the DSPIN function block must not be altered.

The enabled function block (input EN = 1) reads a DSP from the AF100 coupler 07 KP 95.

**EN** BINARY

Enable block processing. Values:  
 EN = 0: The block is not processed.  
 The outputs VAL and ERR are reset to zero.  
 EN = 1: The block is processed.

**#ID** DIRECT CONSTANT

At the input #ID the identifier of the DSP is defined. This identifier results together with the input #ST into the definite identification of the DSP on the AF100 bus (for status of an other station see input #ST).  
 Valid values:  $1 \leq ID \leq 50$

**Important note:**

The values #ID, #ST, #NB, #NI, #NIL, #NR must be equal to the values #ID, #ST, #NB, #NI, #NIL, #NR of the corresponding DSPOUT function block or the corresponding sending DSP element  
 Valid values:  $\#NB + \#NI + \#NIL + \#NR \leq 8$  and  $\#NB + \#NI + \#NIL + \#NR \geq 1$

**#NB** DIRECT CONSTANT

At the input #NB (number of booleans), the number of packed binary values (32 values) of the DSP is defined.  
 Valid values:  $0 \leq \#NB \leq 8$

**SM** BINARY

At the input SM, the first flag of the binary flag range is given, where the block stores the packed binary values.  
 Example: #NI = 2 and SM = M 01,00  
 the packed binary values (64 values) are stored in the flag range from M 01,00 to M 04,15.

**#NI** DIRECT CONSTANT

At the input #NI (number of integer), the number of words of the DSP is given.  
 Valid values:  $0 \leq \#NI \leq 8$

**SMW** WORD

At the input SMW, the first flag of the word flag range is given, where the block stores the word values.

**#NIL** DIRECT CONSTANT

At the input #NIL (number of integer long), the number of double words of the DSP is given.  
 Valid values:  $0 \leq \#NIL \leq 8$

**SMD** DOUBLE WORD

At the input SMD, the first flag of the double word flag range is given, where the block stores the double word values.

**#NR** DIRECT CONSTANT

At the input #NR (number of real), the number of real values of the DSP is given.  
 Valid values:  $0 \leq \#NR \leq 8$

**SR** DOUBLE WORD

At the input SR, the first flag of the double word flag range is given, where the function block stores the real values. For further processing of the real values (IEEE 754), they must be converted into double word values with the **REALDW** function block.

**#ST** DIRECT CONSTANT

At the input #ST the station address is defined. This address results together with the input #ID into the definite identification of the DSP on the AF100 bus.  
 Valid values:  $1 \leq \#ST \leq 80$   
 With #ST = 128, #ID = station address of the desired station (valid values 1...80), #NB = #NI = #NR = 0 and #NIL = 1 it is possible, to interrogate the status of the station using the address #ID. The status (32 bits) is then available under SMD. The status is coded binary and equals the DIAG output of the AF100 function block.

**#CT** DIRECT CONSTANT

At the input #CT the transmission interval (cycle time) is defined in **ms**. This input defines, how many times a DSP is transmitted on the bus.

Valid values: 1, 2, 4, 8, 16, 32, 64, 128, 256, 512, 1024, 2048, 4096

**VAL** BINARY

At the output VAL it is indicated, that the data of the configured flag ranges are valid. The output VAL is reset to

zero, if within (3 \* #CT) no valid data has been received.

**ERR** BINARY

At the ERR output it is indicated, whether an error has occurred.

In case of an error (partner is no 07 KP 95 or the AF100 coupler 07 KP 95 disables the dual-port RAM), the output ERR is set to 1.

The inputs and outputs can neither be doubled nor inverted.

**CE data**

Runtime:

Basic runtime:

Additional runtime:

Updating of the outputs:

Number of historical values:

Available as of:

07 KR 91/07 KT 92/07 KT 93

µs

yes

0 words

ABB Procontic CS31 07 KR 91 R202/R252 index c  
 07 KT 92 R202/R262 index c  
 07 KT 93 R101 index f  
 07 KT 93 R171 index f

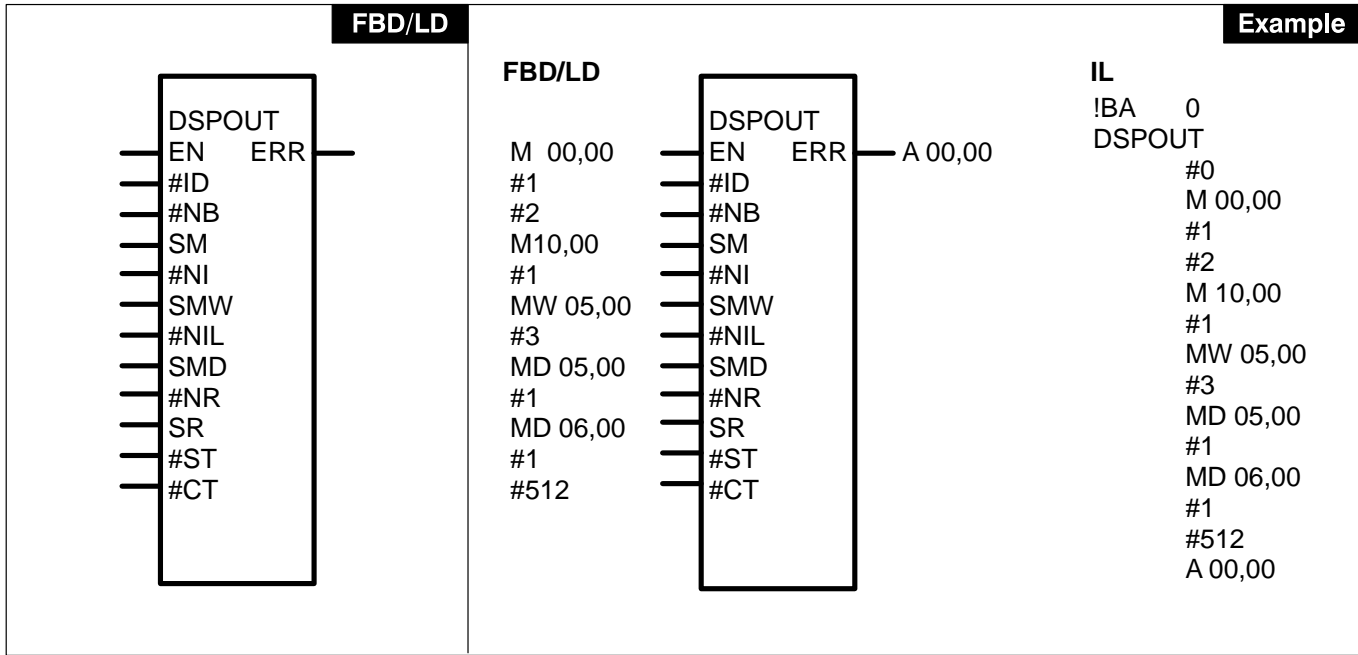

**Parameters**

EN	BINARY	E, M, A, K, S	Enable block processing
#ID	DIRECT CONSTANT	#, #H	Identifier, results together with #ST into the definite identification of the DSP on the AF100 bus; valid values: 1...50
#NB	DIRECT CONSTANT	#, #H	Number of the packed binary values (32 values) of the DSP; valid values: 0...8
SM	BINARY	E, M, A	First flag of the binary range
#NI	DIRECT CONSTANT	#, #H	Number of the word values; valid values: 0...8
SMW	WORD	MW	First word flag of the word range
#NIL	DIRECT CONSTANT	#, #H	Number of the double words of the DSP; valid values: 0...8
SMD	DOUBLE WORD	MD	First double word flag of the double word range
#NR	DIRECT CONSTANT	#, #H	Number of real values; valid values: 0...8
SR	DOUBLE WORD	MD	First double word flag of the real range
		valid values for #NB, #NI, #NIL and #NR: #NB + #NI + #NIL + #NR ≤ 8 and #NB + #NI + #NIL + #NR ≥ 1	
#ST	DIRECT CONSTANT	#, #H	Station address; valid values: 1...80
#CT	DIRECT CONSTANT	#, #H	Transmission interval (cycle time) in ms; valid values: 1, 2, 4, 8, 16, 32, 64, 128, 256, 512, 1024, 2048, 4096
ERR	BINARY	A, M	An error has occurred

## Description

The function block DSPOUT writes a DSP (data set peripheral) to the AF100 coupler 07 KP 95 (Advant Fieldbus 100 coupler). This DSP can be received from other stations over the AF100 bus. The function block DSPOUT is similar to the Element Sending DSP of the Advant controllers.

The inputs #NB, SM through #NR, SR define the composition of the DSP. The inputs #ID and #ST define the definite identification of the DSP on the AF100 bus. For each bus, this identification may be used only by **one** DSPOUT block (or Sending DSP for the Advant controller), but by **several** DSPIN blocks (or Receiving DSPs for the Advant Controllers).

The DSP, which is written by the DSPOUT function block, is read by an other station with the DSPIN function block (or receiving DSP element). The values #ID, #ST, #NB, #NI, #NIL, #NR of the DSPIN function block (receiving DSP element) must be equal to the values #ID, #ST, #NB, #NI, #NIL, #NR of the corresponding DSPOUT function block.

### Important note:

During program modifications on running programs the DSPOUT function block must neither be deleted nor added, and the inputs of the DSPOUT function block must not be altered.

The enabled function block (input EN = 1) writes a DSP to the AF100 coupler 07 KP 95.

### EN BINARY

Enable block processing. Values:

EN = 0: The block is not processed.  
The output ERR is reset to zero.

EN = 1: The block is processed.

### #ID DIRECT CONSTANT

At the input #ID the identifier of the DSP is defined. This identifier results together with the input #ST into the definite identification of the DSP on the AF100 bus.

Valid values:  $1 \leq \#ID \leq 50$

### Important note:

The values #ID, #ST, #NB, #NI, #NIL, #NR must be equal to the values #ID, #ST, #NB, #NI, #NIL, #NR of the corresponding DSPIN function block or the corresponding receiving DSP element

Valid values:  $\#NB + \#NI + \#NIL + \#NR \leq 8$  and  
 $\#NB + \#NI + \#NIL + \#NR \geq 1$

### #NB DIRECT CONSTANT

At the input #NB (number of booleans), the number of packed binary values (32 values) of the DSP is defined, which are to be sent.

Valid values:  $0 \leq \#NB \leq 8$

### SM BINARY

At the input SM, the first flag of the binary flag range is given, which are to be sent.

Example: #NI = 2 and SM = M 01,00  
the packed binary values from  
M 01,00 to M 04,15 (64 values)  
are sent within the DSP.

### #NI DIRECT CONSTANT

At the input #NI (number of integer), the number of words of the DSP is given, which are to be sent.

Valid values:  $0 \leq \#NI \leq 8$

### SMW WORD

At the input SMW, the first flag of the word flag range is given, which is to be sent.

### #NIL DIRECT CONSTANT

At the input #NIL (number of integer long), the number of double words of the DSP is given, which are to be sent.

Valid values:  $0 \leq \#NIL \leq 8$

### SMD DOUBLE WORD

At the input SMD, the first flag of the double word flag range is given, which is to be sent.

### #NR DIRECT CONSTANT

At the input #NR (number of real), the number of real values of the DSP is given, which are to be sent.

Valid values:  $0 \leq \#NR \leq 8$

### SR DOUBLE WORD

At the input SR, the first flag of the double word flag range is given, which is to be sent. Previously, the processed double words must be converted into the corresponding real values (IEEE 754), using the **DWREAL** function block.

### #ST DIRECT CONSTANT

At the input #ST the station address is defined. This address results together with the input #ID into the definite identification of the DSP on the AF100 bus.

Valid values:  $1 \leq \#ST \leq 80$

### #CT DIRECT CONSTANT

At the input #CT the transmission interval (cycle time) is defined in **ms**. This input defines, how many times a DSP is transmitted on the bus.

Valid values: 1, 2, 4, 8, 16, 32, 64, 128, 256, 512,  
1024, 2048, 4096

### ERR BINARY

At the ERR output it is indicated, whether an error has occurred.

In case of an error (partner is no 07 KP 95 or the AF100 coupler 07 KP 95 disables the dual-port RAM), the output ERR is set to 1.

The inputs and outputs can neither be doubled nor inverted.

---

**CE data**

Runtime:	07 KR 91/07 KT 92/07 KT 93
Basic runtime:	μs
Additional runtime:	
Updating of the outputs:	yes
Number of historical values:	0 words
Available as of:	ABB Procontic CS31
	07 KR 91 R202/R252 index c
	07 KT 92 R202/R262 index c
	07 KT 93 R101 index f
	07 KT 93 R171 index f

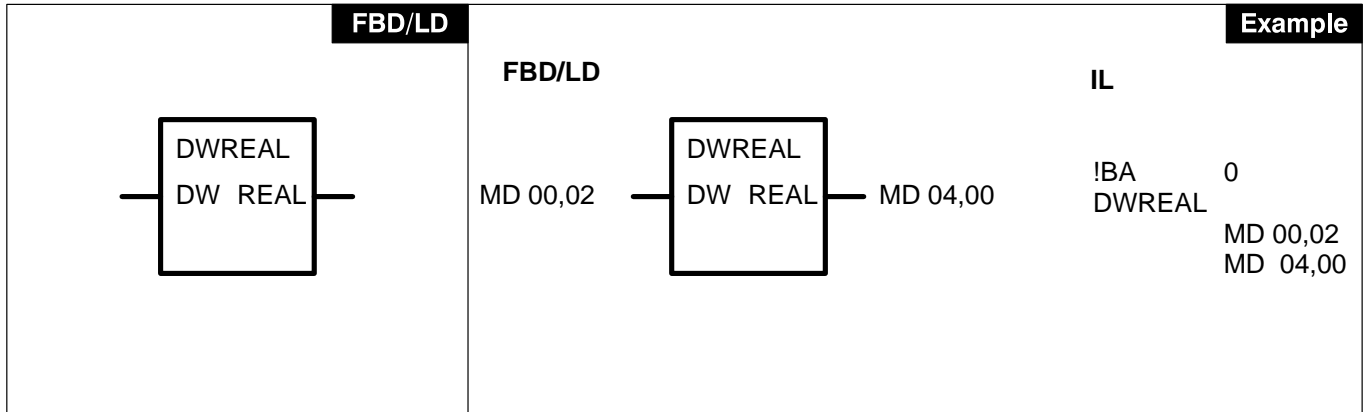

**Parameter**

E1 DOUBLE WORD KD, MD double word to be converted  
 A1 DOUBLE WORD MD result of the conversion, double word

**Description**

The value of the double word operand E1 is converted into a real value (IEEE 754). The result is allocated to the double word operand at the output A1. This function module is appropriate in conjunction with the function module **DSPOUT** only. With that it is possible to transmit real values via the Advant Fieldbus 100.

**E1 DOUBLE WORD**

The value of the double word operand at E1 input is converted into a real value (IEEE 754). The result is available as value of the output operand A1.

**A1 DOUBLE WORD**

The real value (IEEE 754) of E1 is available at output A1.

The inputs and outputs can neither be doubled nor inverted.

**Data formats in accordance with IEEE754**

31	30	23	22	0
s		e		f

s: sign (1 bit)  
 e: biased exponent (8 bits)  
 f: significant (23 bits)

e	f	represented value
255	!0	Not a Number, NaN
255	0	$(-1)^s * \text{infinite}$
1...254		$(-1)^s * 2^{e-127} * (1.f)$
0	!0	$(-1)^s * 2^{-126} * (0.f)$
0	0	$(-1)^s * 0$ , zero

**CE Data**

Run time: 07 KR 91 / 07 KT 92 / 07 KT 93  
 Basic run time: 27 to 65 μs  
 Additional run time: -  
 Output updating: yes  
 Number of historical values: 0 words  
 Available as of: ABB Procontic CS31 07 KR 91 R202/R252 index b  
 07 KT 92 R202/R262  
 07 KT 93 R101 index d  
 07 KT 93 R171 index c

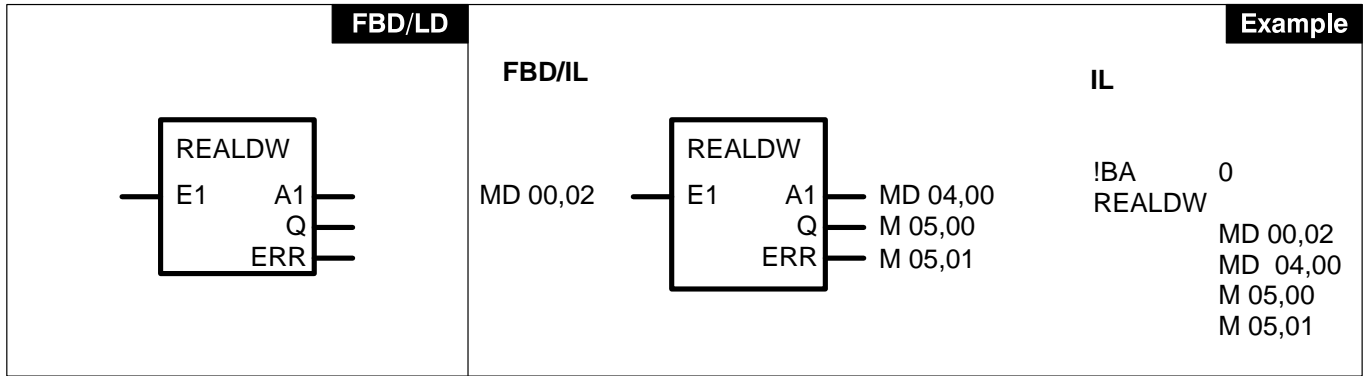

**Parameter**

<p><b>E1</b>     DOUBLE WORD KD, MD</p> <p><b>A1</b>     DOUBLE WORD MD</p> <p><b>Q</b>      BINARY            A, M</p> <p><b>ERR</b>    BINARY            A, M</p>	<p>double word to be converted</p> <p>result of the conversion, double word</p> <p>result limited</p> <p>error occurred (Not a Number)</p>
---	--

**Description**

The real value (IEEE 754) at input E1 is converted into a double word value. The result is allocated to the double word operand at the output A1. This function module is appropriate in conjunction with the function module **DSPIN** only. With that it is possible to transmit real values via the Advant Fieldbus 100.

The result is limited to maximum or minimum number range.

max. number range: + 2 147 483 647 (7FFF FFFF<sub>H</sub>)  
 min. number range: - 2 147 483 647 (8000 0001<sub>H</sub>)

**E1**     DOUBLE WORD

The real value (IEEE 754) at input E1 is converted into a double word value. The result is available as value of the output A1.

**A1**     DOUBLE WORD

The double word value of E1 is available at output A1.

**Q**      BINARY

If a limitation took place, a 1 signal is allocated to the binary operand at output Q.

If no limitation took place, a 0 signal is allocated to the binary operand at output Q.

**ERR**     BINARY

If the real value represents 'Not a Number', the following is valid:

A1 = 0 and Q = 0 and ERR = 1.

The inputs and outputs can neither be doubled nor inverted.

**Data formats in accordance with IEEE754**

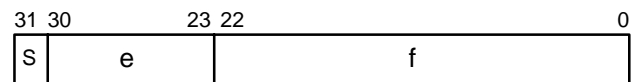

- s: sign (1 bit)
- e: biased exponent (8 bits)
- f: significant (23 bits)

e	f	represented value
255	!0	Not a Number, NaN
255	0	$(-1)^s * \text{infinite}$
1...254		$(-1)^s * 2^{e-127} * (1.f)$
0	!0	$(-1)^s * 2^{-126} * (0.f)$
0	0	$(-1)^s * 0$ , zero

**CE Data**

Run time: 07 KR 91 / 07 KT 92 / 07 KT 93  
Basic run time: 35 to 66  $\mu$ s  
Additional run time: –  
Output updating: yes  
Number of historical values: 0 words  
Available as of: ABB Procontic CS31 07 KR 91 R202/R252 index b  
07 KT 92 R202/R262  
07 KT 93 R101 index d  
07 KT 93 R171 index c







Printed on chlorine-free bleached paper

---

**ABB Schalt- und Steuerungstechnik GmbH**  
Eppelheimer Straße 82 Postfach 10 50 09  
D-69123 Heidelberg D-69040 Heidelberg

Telephone +49 6221 777-0  
Telefax +49 6221 777-111  
E-Mail [desst.help@de.abb.com](mailto:desst.help@de.abb.com)  
Internet <http://www.abb-sst.de>

Printed in the Federal Republic of Germany (09.97)