



Accessories - Marking

Summary

E1 - Accessories	181
E2 - Marking	193

Range of plugs

ABB Entelec offers a wide range of Interfast plugs.

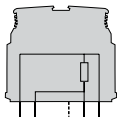

Converter plug

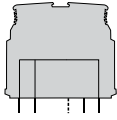

Strap 2 plug

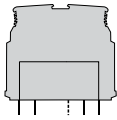

Strap 1 plug

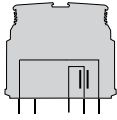

Input fuse plug

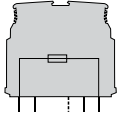

Output fuse plug

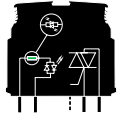

AC output optocoupler plug

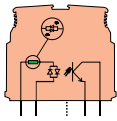

DC output optocoupler plug

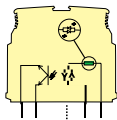

AC input optocoupler plug

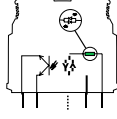

DC input optocoupler plug

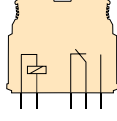

Relay plug

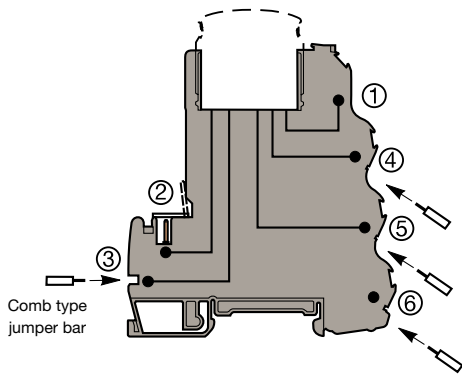
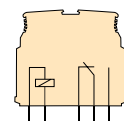
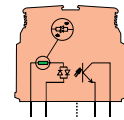
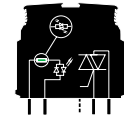
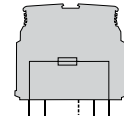
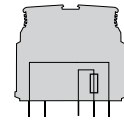
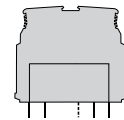
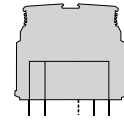

Terminal block without LED

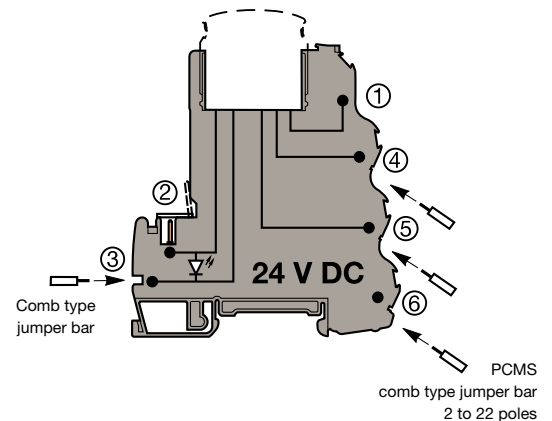

Terminal block with LED

ACCESSORIES

BNMS

Model 1plugs

Input optocoupler plugs (See Characteristics on the next pages)

125 V DC	BNMS T125V-1	White	0031 831.03
24 V DC	BNMS T24V-1	White	0031 800.21
48 V DC	BNMS T48V-1	White	0031 801.16
5 V DC	BNMS T5V-1	White	0031 845.11
24 V AC	BNMS T24V-1	Yellow	0031 802.17
48 V AC	BNMS T48V-1	Yellow	0031 803.10
115 V AC	BNMS T115V-1	Yellow	0031 804.11
230 V AC	BNMS T230V-1	Yellow	0031 805.12

Output optocoupler plugs (See Characteristics on the next pages)

24 V DC 100 mA	BNMS N24V-3	Red	0031 807.14
24 V DC 100 mA	BNMS P24V-3	Red	0031 810.12
24 V DC 2 A	BNMS N24V-1	Red	0031 813.01
24 V DC 2 A	BNMS P24V-1	Red	0031 815.03
24 V DC 1 A	BNMS N24V-2	Red	0031 817.05
24 V DC 1 A	BNMS P24V-2	Red	0031 819.17

Relay plug (See Characteristics on the next pages)

1 RT	BNMS R24V-1	Ivory	0031 820.14
------	-------------	-------	-------------

Fuse plug

125 V / 125 mA	BNMS F125mA-1	Grey	0031 821.01
125 V / 500 mA	BNMS F250mA-1	Grey	0031 838.12
125 V / 2 A	BNMS F2A-1	Grey	0031 822.02
125 V / 5 A	BNMS F5A-1	Grey	0031 823.03
250 V / 125 mA	BNMS F125mA-2	Grey	0031 824.04
250 V / 2 A	BNMS F2A-2	Grey	0031 825.05
250 V / 5 A	BNMS F5A-2	Grey	0031 826.06

Fuse plug

125 V / 125 mA	BNMS F125mA-3	Grey	0031 827.07
250 V / 125 mA	BNMS F125mA-4	Grey	0031 828.10

Strap plug

BNMS ST1	Grey	0031 829.11
BNMS ST2	Grey	0031 830.16

Model 2 plugs

Output optocoupler plugs (See Characteristics on the next pages)

5 V DC 100 mA	BNMS N5V-3	Red	0031 806.13
5 V DC 100 mA	BNMS P5V-3	Red	0031 809.26
48 V DC 100 mA	BNMS N48V-3	Red	0031 808.25
48 V DC 100 mA	BNMS P48V-3	Red	0031 811.07
5 V DC 2 A	BNMS N5V-1	Red	0031 812.00
5 V DC 2 A	BNMS P5V-1	Red	0031 814.02
5 V DC 1 A	BNMS N5V-2	Red	0031 816.04
5 V DC 1 A	BNMS P5V-2	Red	0031 818.16

Converter plug (See Characteristics on the next pages)

0 - 20 mA 0 - 10 V	BNMS CAI/U-500	Grey	0031 832.04
4 - 20 mA 2 - 10 V	BNMS CAI/U-500	Grey	0031 832.04
0 - 20 mA 0 - 5 V	BNMS CAI/U-250	Grey	0031 833.05
4 - 20 mA 1 - 5 V	BNMS CAI/U-250	Grey	0031 833.05

interfast MS

Fuse and strap plugs

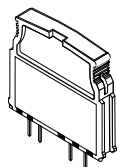

Output fuse plug

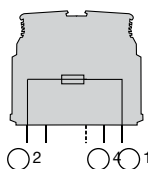

Input fuse plug

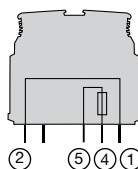

Strap plug

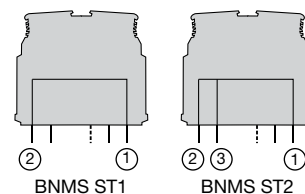

Part numbers

Type

P/N

BNMS F125mA-1	125 V / 125 mA	0031 821.01
BNMS F500mA-1	125 V / 500 mA	0031 838.12
BNMS F2A-1	125 V / 2 A	0031 822.02
BNMS F5A-1	125 V / 5 A	0031 823.03
BNMS F125mA-2	250 V / 125 mA	0031 824.04
BNMS F2A-2	250 V / 2 A	0031 825.05
BNMS F5A-2	250 V / 5 A	0031 826.06

Type

P/N

BNMS F125mA-3	125 V / 125 mA	0031 827.07
BNMS F125mA-4	250 V / 125 mA	0031 828.10

Type

P/N

BNMS ST1	0031 829.11
BNMS ST2	0031 830.16

interfast MS

Input optocoupler plugs

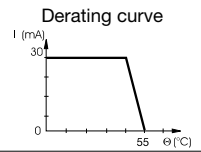
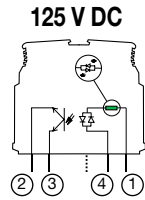
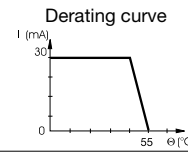
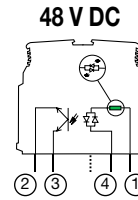
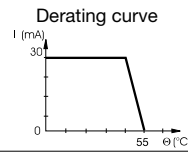
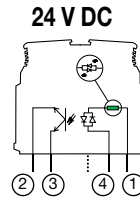
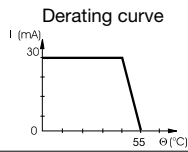
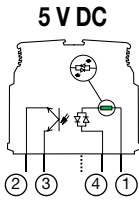
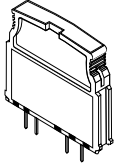

Part number	Type	P/N	Type	P/N	Type	P/N	Type	P/N
		BNMS T5V-1	0031 831.03	BNMS T24V-1	0031 800.21	BNMS T48V-1	0031 801.16	BNMS T125V-1
Characteristics								
INPUT								
Voltage	4,5 V to 5,5 V DC		19,2 V to 27,6 V DC		38,4 V to 55,2 V DC		93,5 V to 140 V DC	
Max. current	6 mA		5 mA		4,1 mA			
Typical triggering threshold at $I_s = 100\%$	3,5 V		12 V DC		21 V DC			
Switching time	20 μ s / 1,3 ms		20 μ s / 1,3 ms		20 μ s / 1,3 ms			
Leakage current	C/O		1 mA		0,8 mA			
OUTPUT	58 V / 30 mA		58 V / 30 mA		58 V / 30 mA		58 V / 30 mA	
Max. voltage. / Max. current	2,3 V DC		2,3 V DC		2,3 V DC		2,3 V DC	
Residual voltage max. I and rated U standard max.	2,7 V DC		2,7 V DC		2,7 V DC		2,7 V DC	
Input / Output isolation	2,5 kV		2,5 kV		2,5 kV		2,5 kV	
TEMPERATURE	- 30°C to + 80°C		- 30°C to + 80°C		- 30°C to + 80°C		- 30°C to + 80°C	
Storage	- 20°C to + 55°C		- 20°C to + 55°C		- 20°C to + 55°C		- 20°C to + 55°C	
Operating								

interfast MS

Input optocoupler plugs

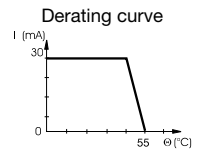
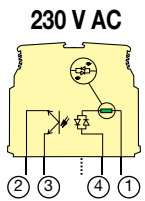
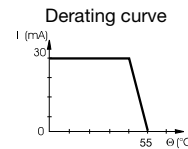
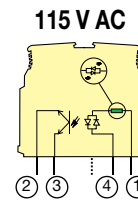
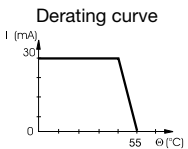
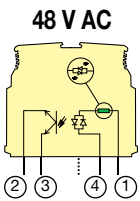
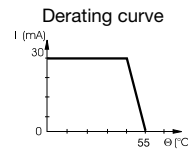
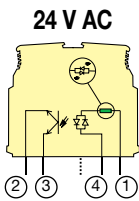
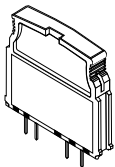

Part number	Type	P/N	Type	P/N	Type	P/N	Type	P/N
		BNMS T24V-1	0031 802.17	BNMS T48V-1	0031 803.10	BNMS T115V-1	0031 804.11	BNMS T230V-1
Charateristics								
INPUT								
Voltage	20,4 V to 26,4 V AC		40,8 V to 52,8 V AC		98 V to 126,5 V AC		195,5 V to 253 V AC	
Max. current	8,5 mA		4,5 mA		8 mA		7 mA	
Typical triggering threshold at $I_s = 100\%$	13 V AC		22 V AC		50 V AC		95 V AC	
Switching time	6 ms / 10 ms		6 ms / 10 ms		6 ms / 10 ms		6 ms / 10 ms	
Leakage current	C/O		1 mA		2 mA			
OUPUT	58 V / 30 mA		58 V / 30 mA		58 V / 30 mA		58 V / 30 mA	
Max. voltage / Max. current	2,3 V DC		2,3 V		2,3 V		2,3 V	
Residual voltage max. I and rated U standard max.	2,7 V DC		2,7 V		2,7 V		2,7 V	
Input / Output isolation	2,5 kV		2,5 kV		2,5 kV		2,5 kV	
TEMPERATURE	- 30°C to + 80°C		- 30°C to + 80°C		- 30°C to + 80°C		- 30°C to + 80°C	
Storage	- 20°C to + 55°C		- 20°C to + 55°C		- 20°C to + 55°C		- 20°C to + 55°C	
Operating								

interfast MS

Transistor output optocoupler plugs

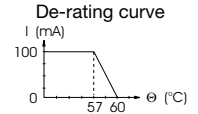
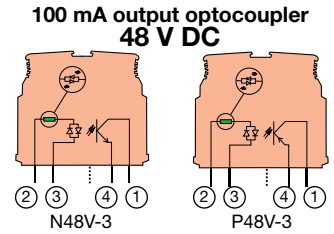
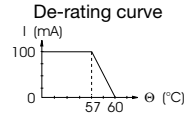
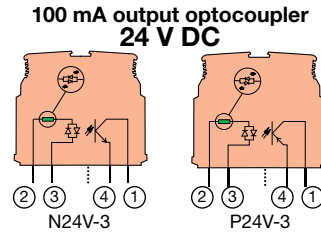
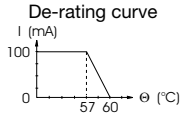
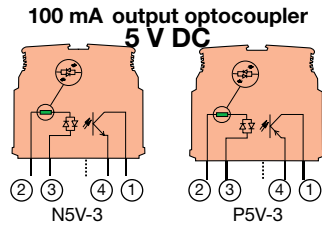
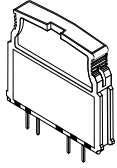

Part numbers	Type	P/N	Type	P/N	Type	P/N
	BNMS N5V-3	0031 806.13	BNMS N24V-3	0031 807.14	BNMS N48V-3	0031 808.25
	BNMS P5V-3	0031 809.26	BNMS P24V-3	0031 810.12	BNMS P48V-3	0031 811.07
Characteristics						
INPUT						
Voltage	4,5 V to 5,5 V DC		20,4 V to 28,8 V DC		40,8 V to 57,6 V DC	
Max. current	8,5 mA		4,8 mA		3,9 mA	
Typical triggering threshold at Is = 100 %	2,9 V DC		16 V DC		26 V DC	
Switching time C/O	20 µs / 1,3 ms		20 µs / 1,3 ms		20 µs / 1,3 ms	
Leakage current	1 mA		1 mA		1 mA	
OUTPUT						
Max. voltage / Max. current	58 V / 100 mA		58 V / 100 mA		58 V / 100 mA	
Residual voltage max. I and rated U standard U max.	1 V DC 1,3 V DC		1 V DC 1,3 V DC		1 V DC 1,3 V DC	
Frequency on inductive load	See Note 1		See Note 1		See Note 1	
Input / Output isolation	2,5 kV		2,5 kV		2,5 kV	
TEMPERATURE						
Storage	- 30°C to + 80°C		- 30°C to + 80°C		- 30°C to + 80°C	
Operating	- 20°C to + 60°C		- 20°C to + 60°C		- 20°C to + 60°C	

interfast MS

MOS output optocoupler plugs

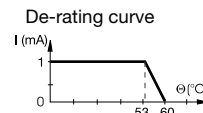
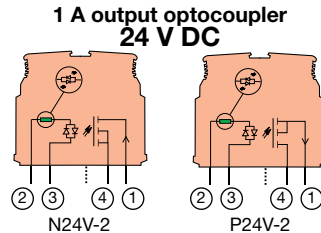
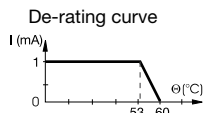
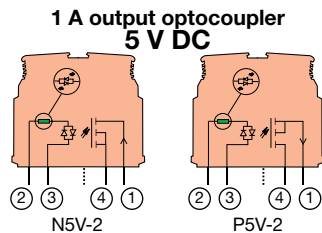
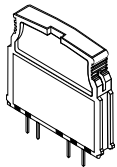

Part numbers	Type	P/N	Type	P/N
	BNMS N5V-2	0031 816.04	BNMS N24V-2	0031 817.05
	BNMS P5V-2	0031 818.16	BNMS P24V-2	0031 819.17
Characteristics				
INPUT				
Voltage	4,5 V to 5,5 V DC		20,4 V to 28,8 V DC	
Max. current	12,5 mA		6,7 mA	
Typical triggering threshold at Is=100%	3,5 V DC		10 V DC	
Switching time C/O	20 µs / 250 µs		50 µs / 350 µs	
Leakage current	1 mA		1 mA	
OUTPUT				
Max. voltage / Max. current	58 V / See graphs		58 V / See graphs	
Residual voltage max. I and rated U standard U max.	1 V DC 1,3 V DC		1 V DC 1,3 V DC	
Frequency on inductive load	See Note 1		See Note 1	
Input / Output isolation	2,5 kV		2,5 kV	
TEMPERATURE				
Storage	- 30°C to + 80°C		- 30°C to + 80°C	
Operating	- 20°C to + 60°C		- 20°C to + 60°C	

Note 1 :

$$F_{max} = (1 - 0,007 \times U_s) / (L \times I_s^2)$$

or

$$F_{max} = (1 - 0,007 \times U_s) / (P \times \frac{L}{R})$$

Us = Output voltage supply
Is = Output current
L = Inductive load
P = Load power
R = Load resistance

interfast MS 

MOS output optocoupler plug

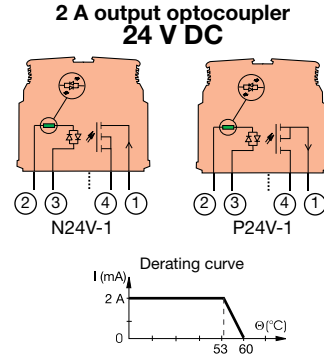
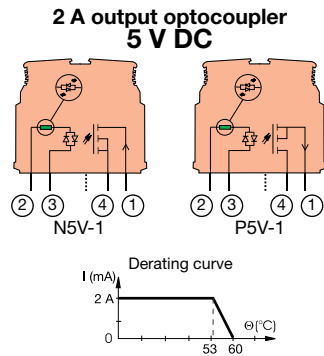
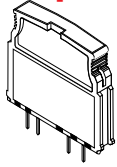

Note 2 :

$$F_{max} = (1 - 0,012 \times U_s) / (L \times I_s^2)$$

or

$$F_{max} = (1 - 0,012 \times U_s) / (P \times \frac{L}{R})$$

U_s = Output voltage supply
 I_s = Output current
 L = Inductive load
 P = Load power
 R = Load resistance

Part numbers	Type	P/N	Type	P/N
	BNMS N5V-1	0031 812.00	BNMS N24V-1	0031 813.01
	BNMS P5V-1	0031 814.02	BNMS P24V-1	0031 815.03
Characteristics				
INPUT				
Voltage	4,5 V to 5,5 V DC		20,4 V to 28,8 V DC	
Max. current	12,5 mA		6,7 mA	
Typical triggering threshold	3,5 V DC		10 V DC	
Switching time	C/O	20 μs / 250 μs	50 μs / 350 μs	
Leakage current	1 mA		1 mA	
OUTPUT				
Max. voltage / Max. current	30 V DC / See graphs		30 V / See graphs	
Residual voltage max. I and rated U				
standard U	1 V DC		1 V DC	
max.	1,3 V DC		1,3 V DC	
Frequency on inductive load	See Note 2		See Note 2	
Input / Output isolation	2,5 kV		2,5 kV	
TEMPERATURE				
Storage	- 30°C to + 80°C		- 30°C to + 80°C	
Operating	- 20°C to + 60°C		- 20°C to + 60°C	

interfast MS 

Triac output optocoupler plug

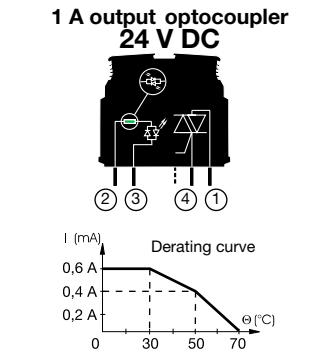
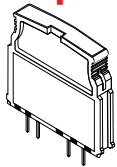

Part numbers	Type	P/N
	BNMS A24V-4	0031 839.13
Characteristics		
INPUT		
Voltage	20,4 V to 28,8 V DC	
Max. current	3,8 mA	
Typical triggering threshold	10 V DC	
Switching time	C/O	9,5 ms / 12 ms
Leakage current		
OUTPUT		
Max. voltage / Max. current	24 V to 253 V AC / See derating curve	
Residual voltage max. I and rated U		
standard U	1 V AC	
max.	1,3 V AC	
Input / Output isolation	2,5 kV	
TEMPERATURE		
Storage	- 30°C to + 80°C	
Operating	- 20°C to + 70°C	

omnicconnect P.C.B. connectors

Screw-clamp connection
Spacing 5.08 mm
Body : UL94 V0



CPFT2 / ...

Plugs,
wires parallel to connection
Spacing 5,08 mm .200"

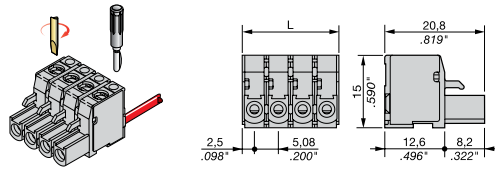

CPFT2 / R-...

Plugs,
wires perpendicular to connection
Spacing 5,08 mm .200"

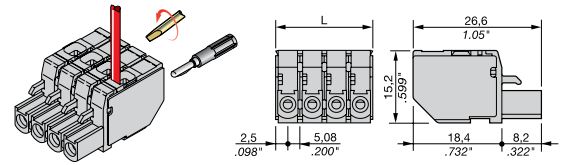

Characteristics

Wire size

	IEC	UL	CSA
Solid*	0-2,5 mm ²	24-12 AWG	24-12 AWG
Stranded*	0-2,5 mm ²		

Voltage

V	250	300	300

Current

A	12	15	15

Rated wire size

	2,5 mm ²	12 AWG	12 AWG

Other characteristics

Wire stripping length	Recomm. screwdriver	Recomm. torque	Protection
7,5 mm .295"	3,5 mm .137"	0,4 Nm 3.5 lb.in	IP 20 NEMA 1

Max. working temperature	100° C
Contact resistance	< 5 m Ω

Approvals			

Number of poles Type Part number

Spacing 5,08 mm .200" black body		
2	CPFT2 / 2	0094 302.21
3	CPFT2 / 3	0094 303.22
4	CPFT2 / 4	0094 304.23
5	CPFT2 / 5	0094 305.24
6	CPFT2 / 6	0094 306.25
7	CPFT2 / 7	0094 307.26
8	CPFT2 / 8	0094 308.07
9	CPFT2 / 9	0094 309.00
10	CPFT2 / 10	0094 310.24
11	CPFT2 / 11	0094 311.11
12	CPFT2 / 12	0094 312.12
13	CPFT2 / 13	0094 313.13
14	CPFT2 / 14	0094 314.14
15	CPFT2 / 15	0094 315.15
16	CPFT2 / 16	0094 316.16
17	CPFT2 / 17	0094 317.17
18	CPFT2 / 18	0094 318.20
19	CPFT2 / 19	0094 319.21
20	CPFT2 / 20	0094 320.26
21	CPFT2 / 21	0094 321.13
22	CPFT2 / 22	0094 322.14
23	CPFT2 / 23	0094 323.15
24	CPFT2 / 24	0094 324.16

Number of poles Type Part number

Spacing 5,08 mm .200" black body		
2	CPFT2 / R-2	0094 352.22
3	CPFT2 / R-3	0094 353.23
4	CPFT2 / R-4	0094 354.24
5	CPFT2 / R-5	0094 355.25
6	CPFT2 / R-6	0094 356.26
7	CPFT2 / R-7	0094 357.27
8	CPFT2 / R-8	0094 358.00
9	CPFT2 / R-9	0094 359.01
10	CPFT2 / R-10	0094 360.06
11	CPFT2 / R-11	0094 361.23
12	CPFT2 / R-12	0094 362.24
13	CPFT2 / R-13	0094 363.25
14	CPFT2 / R-14	0094 364.26
15	CPFT2 / R-15	0094 365.27
16	CPFT2 / R-16	0094 366.20
17	CPFT2 / R-17	0094 367.21
18	CPFT2 / R-18	0094 368.02
19	CPFT2 / R-19	0094 369.03
20	CPFT2 / R-20	0094 370.00
21	CPFT2 / R-21	0094 371.25
22	CPFT2 / R-22	0094 372.26
23	CPFT2 / R-23	0094 373.27
24	CPFT2 / R-24	0094 374.20

Housing kits

Spacing 5.08 mm
Body : UL94 V0

CPFIC5 / ... Plug housings

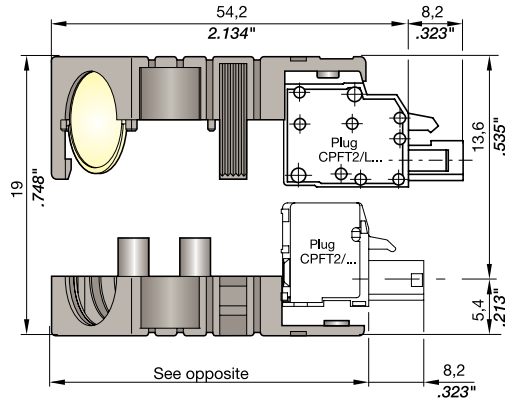
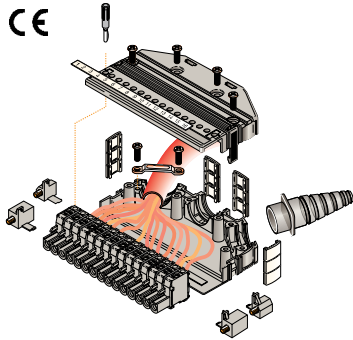

Number of poles	Type	Part number
-----------------	------	-------------

Spacing 5,08 mm .200" black body		
3	CPFIC5 / 3	0299 337.05
4	CPFIC5 / 4	0299 249.25
6	CPFIC5 / 6	0299 064.07
8	CPFIC5 / 8	0299 253.11
10	CPFIC5 / 10	0299 257.15
11	CPFIC5 / 11	0299 261.11
12	CPFIC5 / 12	0299 265.15
16	CPFIC5 / 16	0299 286.03
18	CPFIC5 / 18	0299 292.01
20	CPFIC5 / 20	0299 298.17
24	CPFIC5 / 24	0299 304.15

3 poles housing	cable Ø : 4 to 7 mm
4 poles housing	cable Ø : 4 to 9 mm
This kit includes: 1 separator + 1 cover + 1 strap	
6 poles housing	cable Ø : 3 to 12 mm
This kit includes: 1 separator + 1 cover + 1 flange + 2 self-tapping screws	
8 poles housing	cable Ø : 4 to 15 mm
10 to 12 poles housing	cable Ø : 4 to 15 mm
This kit includes: 1 separator + 1 cover + 1 flange + 2 self-tapping screws	
16 to 24 poles housing	cable Ø : 4 to 15 mm
This kit includes: 1 separator + 1 cover + 1 flange + 2 self-tapping screws	

Accessories

Type	Part number	P/N black	P/N grey
------	-------------	-----------	----------

1	Insert sleeve (8 to 24 poles cover)	0177 442.24	0179 518.02
2	Plastic strap	0179 507.00	
3	Tightening screw	0178 801.06	
4	Tightening flange	0176 192.11	

omniconnect CODING ACCESSORIES

Coding peg COPE

0199 322.22



RECOMMENDED SOLUTION
Efficient system with few parts.

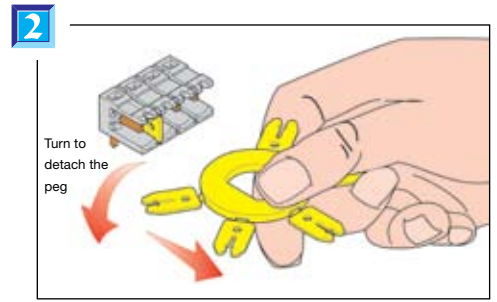
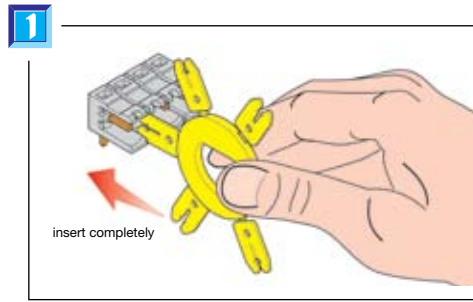

CODING EXAMPLES

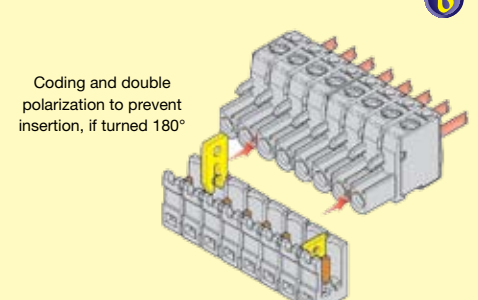
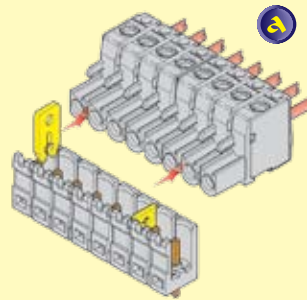
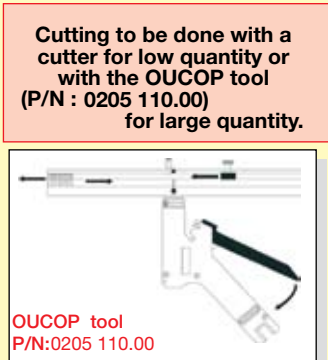
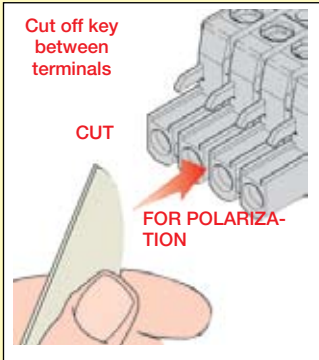

The plug of example **a** cannot be mounted on the socket **b** and vice versa

Terminal blocks MA 2,5/5 - CPE...

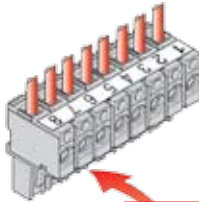

Coding peg for COC1

0299 777.16



Terminal blocks MA 2,5/5D2 ... - 2CPE...

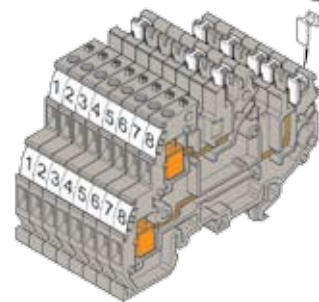
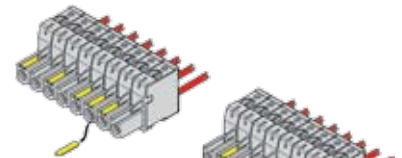

CAUTION !
The 2 outputs for plugs are inverted. **Blocking highly recommended.**

If one set is not used, mount blocking pegs to prevent a plug from being mounted on the output.

If both outputs are used, coding is highly recommended.

Blocking peg COCF 32

0173 660.16



Blocking peg to be mounted on the pins of the unused output (to be ordered separately).

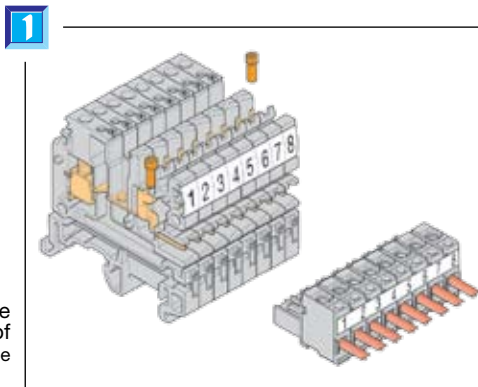

Detachable protection CPF 5,08

0199 323.23



Detachable protection to be mounted on the unused connection part of the plug (supplied with the terminal block).

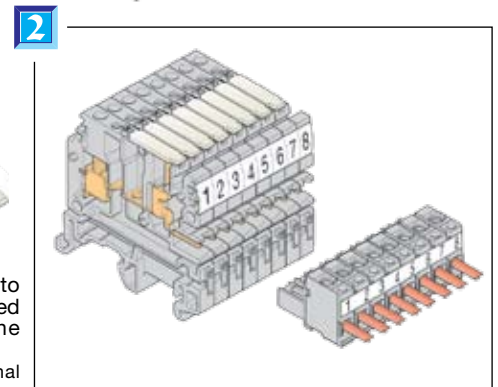

Accessories

PCMS

Comb-type jumper

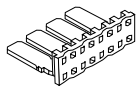

This accessory permits the electrical connection of 2 to 22 blocks.

No. of poles	Grey UL94V0	Red UL94V0	Blue UL94V0	Green/Yellow UL94V0
2	0205 491.23	0205 492.24	0205 493.25	0205 494.26
3	0205 495.27	0205 496.20	0205 497.21	0205 498.02
4	0205 499.03	0205 500.10	0205 501.05	0205 502.06
5	0205 503.07	0205 504.00	0205 505.01	0205 506.02
6	0205 507.03	0205 508.14	0205 509.15	0205 510.01
7	0205 511.26	0205 512.27	0205 513.20	0205 514.21
8	0205 515.22	0205 516.23	0205 517.24	0205 518.05
9	0205 519.06	0205 520.03	0205 521.20	0205 522.21
10	0205 523.22	0205 524.23	0205 525.24	0205 526.25
11	0205 527.26	0205 528.07	0205 529.00	0205 530.05
12	0205 531.22	0205 532.23	0205 533.24	0205 534.25
13	0205 535.26	0205 536.27	0205 537.20	0205 538.01
14	0205 539.02	0205 540.17	0205 541.04	0205 542.05
15	0205 543.06	0205 544.07	0205 545.00	0205 546.01
16	0205 547.02	0205 548.13	0205 549.14	0205 550.11
17	0205 551.06	0205 552.07	0205 553.00	0205 554.01
18	0205 555.02	0205 556.03	0205 557.04	0205 558.15
19	0205 559.16	0205 560.13	0205 561.00	0205 562.01
20	0205 563.02	0205 564.03	0205 565.04	0205 566.05
21	0205 567.06	0205 568.17	0205 569.10	0205 570.15
22	0205 571.02	0205 572.03	0205 573.04	0205 574.05

BFMS AUTO

Fuse plugs

32 V / 2 A	BFMS AUTO	0205 812.24
32 V / 3 A	BFMS AUTO	0205 813.25
32 V / 5 A	BFMS AUTO	0205 814.26



BF5 AUTO

Fuse plugs with extractor

32 V / 2 A	BF5 AUTO	0205 815.27
32 V / 3 A	BF5 AUTO	0205 816.20
32 V / 5 A	BF5 AUTO	0205 817.21



CPMS

Protective cover

12 or 20 poles protective cover	0205 227.01
34 poles protective cover	0206 163.02

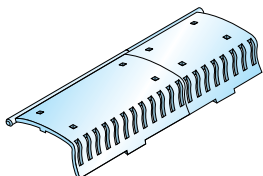

EL

Connector plate

This accessory is used for connecting electrically two assembled interconnections with 5 mm spacing.



EL6 0173 627.21

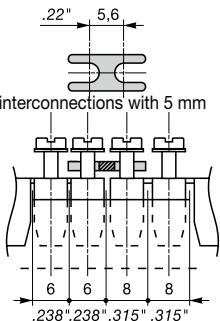

RTMS

Marking strip CPMS for protective cover

12 poles label	0206 530.06
20 poles label	0206 531.23
34 poles label	0206 532.24

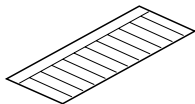

BJM...

Assembled jumper bar

Two versions of this accessory are available.

Fractionable model, composed of captive screws on a jumper bar system. This accessory can be used for connecting consecutive blocks only.

IP20 without protection



Current Capacity, Amps

BJM5 for MA 2,5/5 blocks

24 A	2 poles	0176 273.01
24 A	3 poles	0176 274.02
24 A	4 poles	0176 275.03
24 A	5 poles	0176 276.04
24 A	10 poles	0176 277.05

IP20 with protection



Current Capacity, Amps

BJM5 for MA 2,5/5 blocks

24 A	2 poles	0176 278.16
24 A	3 poles	0176 279.17
24 A	4 poles	0176 280.05
24 A	5 poles	0176 281.22
24 A	10 poles	0176 282.23

PEF

Identification label holders

Designed to hold RPEV label (see opposite).

PEF *	0020 568.04
-------	-------------

* Come with labels.

The label holders are removable and the labels can be changed easily. ● Mounted on PCB in a 3.7 mm diameter hole.

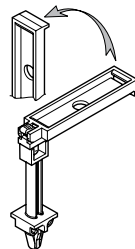

● For mounting on a PCB block in a 2 mm diameter hole (no support leg).

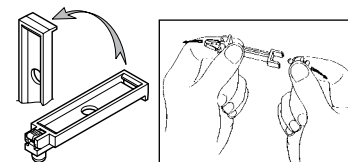

RPEV

Label for PEF 29 x 6 mm

Sheets of 99 pre-cut labels

✓ Blank

RPEV	0173 178.07
------	-------------



PC2MS

PC2MS shunt

10 poles	0400 169.17
12 poles	0400 215.05
20 poles	0400 170.14
34 poles	0400 171.01

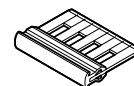

SCMS

Separator

SCMS	0400 172.02
------	-------------

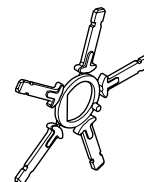

BNS5

Plug with solder tags

Compatible with electronic components and fuses.

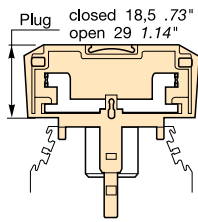

BNS5 **0116 702.24**

Max. diameter or thickness for component :
- Plug BNS5 : 3 mm / .118" maxi.

Soldered fuses 250 V

FUBS	0,5 A	0174 893.16
FUBS	1 A	0174 894.17
FUBS	2 A	0174 895.10
FUBS	3 A	0174 896.11
FUBS	5 A	0174 897.12

CB

Shield connector



Delivered separately, this bar of treated brass is mounted in the lower part of the terminal block. It ensures the continuity of the shield connection. The connection to the shield connector can be made either by soldering or by 2,8 x 0,5 mm or 2,8 x 0,8 mm quick connect tabs. Notch available for bridging all shieldings. This accessory overlaps on each side of the block by about 13,5 mm. Use of this bar reduces insulation between terminal and ground, working voltage must be derated (consult us if necessary).

CBM8	0178 746.15
CBM5	0178 745.14

AL

Test socket

This accessory is screwed into the tapped holes of the connector bar of the terminal blocks. Some blocks are delivered socket mounted. This socket receives an **FC** test plug.

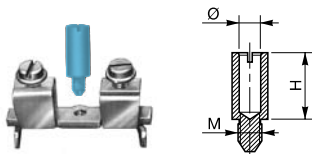

The test sockets are characterized by their internal diameter.

Ø 2 mm H = 11.7 mm .079" DIA. .461" H
M2,6 AL2 0163 046.24

SC

Circuit separator and separator end section

Snap-on end sections for blocks / separators

SCF

An SCF separator is snapped onto the terminal block before mounting on the rail. It can also be used as an end section.

✓ With possibility of mounting a protective cover CPM, and a marker-holder PEP.

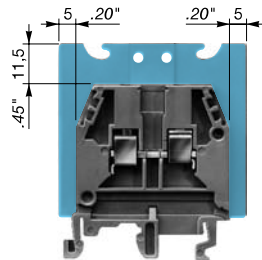

For blocks : **MA 2,5/5**

Thickness : 3 mm .118"

SCF6 grey **0118 707.03**

Snap-on end sections for rails / separators

SCFM6

✓ With possibility of mounting a protective cover CPM, and a marker-holder PEP. Mounting on **PR1, PR3, PR4** and **PR5** rails

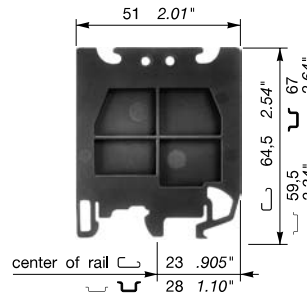

For blocks : **M 4/6**
M 6/8
M 10/10

Thickness : 3 mm .118"

SCFM6 grey **0114 825.05**

BJDL

Jumper bar for spring blocks with same spacing

For blocks spacing 5 mm .200"

BJDL5.2	2 points	0291 102.23
BJDL5.3	3 points	0291 103.24
BJDL5.4	4 points	0291 104.25
BJDL5.5	5 points	0291 105.26
BJDL5.6	6 points	0291 106.27
BJDL5.7	7 points	0291 107.20
BJDL5.8	8 points	0291 108.01
BJDL5.9	9 points	0291 109.02
BJDL5.10	10 points	0291 110.26

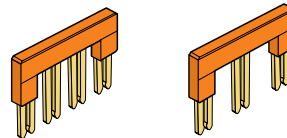

DC

Test device on screw head

This patented device is mounted on the round screwdriver opening. It is used for trouble shooting, measuring and control for monitoring and repairing an installation, on blocks without a test socket. For this, the device receives an **FC2** test plug.

The DC's are differentiated by their colour :

blue for **MA 2,5/5** blocks

DCB **0105 028.21**



SCFEX

Separator for use with explosive atmosphere terminal blocks.

It can also be used for blocks spacing 5 to 16 mm.

✓ Mounting on **PR3** and **PR5** rails

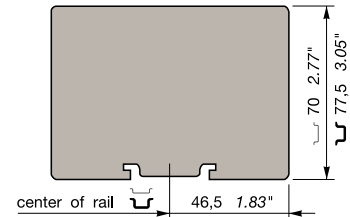

Thickness : 2,4 mm .094"

SCFEX3* grey **0103 620.01**

✓ Mounting on **PR1** rail only.

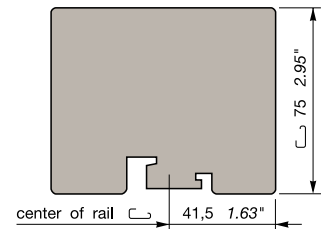

Thickness : 2,4 mm .094"

SCFEX1* grey **0103 619.04**

* When the block used has snap-on feature use circuit separator SCF.

FC

Test plug

These accessories, when used with measuring or control equipment, are used for trouble shooting or testing of a circuit, on the blocks equipped with a test socket or by use of a test device (for **FC2** only).

Test plug DIA. 2 mm .079"
(soldered connection : 1 mm² max. - 18 AWG)

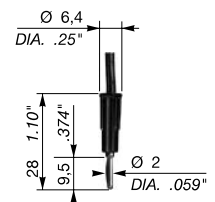

FC2 **0007 865.26**

Mounting rails

- Asymmetrical - DIN 1**
- Symmetrical - DIN 2**
- Symmetrical - DIN 3**

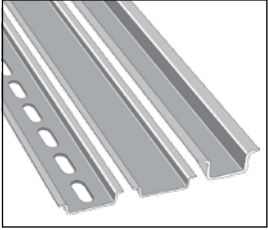
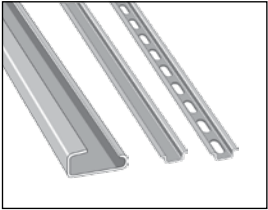

The "Series 5000" terminal blocks snap onto the PR1 asymmetrical DIN 1 rails described here.

The rails are often used as grounding bars. The current carrying capacity of the rails and the copper wire sizes required to carry that current are given below.

RAIL CURRENT CARRYING CAPACITY

Rail	Material	Current (A)	Wire size AWG	mm ²
TS 32	Steel	143	2	35
TS 32 ALU	Aluminium	265	000	95
TS 35/F6	Steel	65	8	10
TS 35	Steel	87	6	16
TS 35/C	Steel	125	4	25
TS 35/C1	Steel	143	2	35

TS 32 / TS 32 ALU

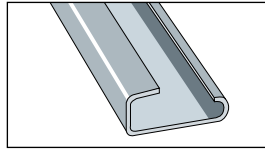
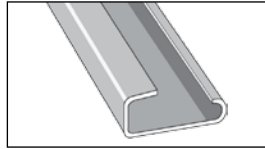

Asymmetrical 32 mm 1.26" G rail in compliance with EN 50035 standard (DIN 46277-1 - NFC 63018) DIN 1

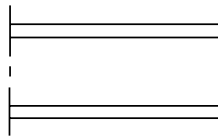
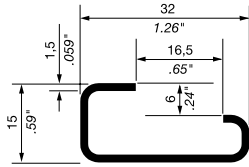

Type	P/N
PR1.Z2 (TS 32)	0163 050.04
White passivated galvanized steel, length 2 m 6'6" (78") approx.	
PR1.A2 (TS 32 ALU)	0167 120.23
Aluminum alloy length 3 m 9'9" (117") approx.	
PR1.Z3	0167 100.00
White passivated galvanized steel, length 3 m 9'9" (117") approx.	

TS 35/C

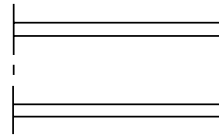
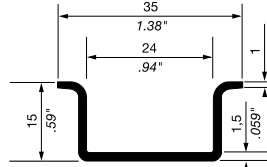
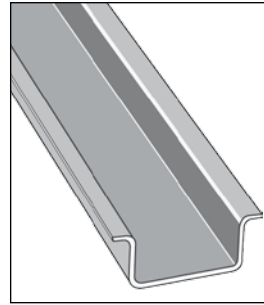

Type	P/N
PR5 (TS 35/C)	0168 700.22
White passivated galvanized steel, length 2 m 6'6" (78") approx.	

TS 35/C1

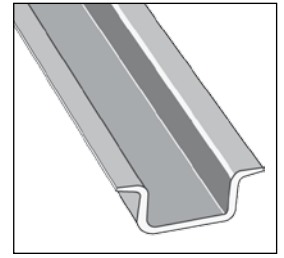

rail in compliance with EN 50022 (NFC 63015) DIN 3

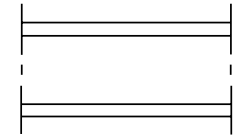
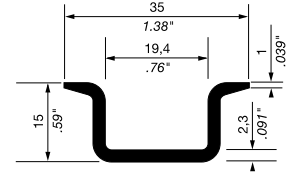

Type	P/N
PR4 (TS 35/C1)	0168 500.12
White passivated galvanized steel, length 2 m 6'6" (78") approx.	

EM

Rail offset brackets

These accessories are available with all rail describes on this page.

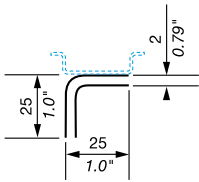

Deflection 90°

EM90 0008 520.01

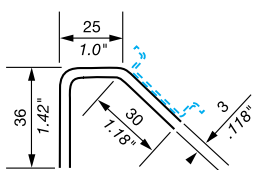

Deflection 45°

EM45 0008 521.26

FX

Mounting nuts

Two nuts, embedded into a 12 mm wide polyamide body, are used for fixing devices on PR1 rail. They stick on the rail. Mounting of the blocks is made using screws (length = width to be tightened + 10 mm). In the table hereunder, the first digit concerns the hole located on the upper side of the rail.

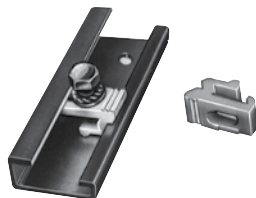

Thread	Colour	Type	Part number
M4-M6	white	FX M4/M6	0163 215.22
M6-M4	grey	FX M6/M4	0163 910.27
M3-M5	yellow	FX M3/M5	0163 811.10
M5-M3	black	FX M5/M3	0163 911.14
M4	blue	FX M4	0163 912.15
M3	green	FX M3	0163 913.16

TS 35/F6

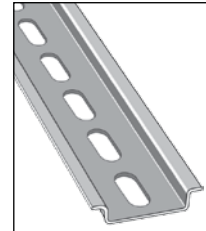

In compliance with EN 50022 standard (DIN 46277-3 - NFC 63015) DIN 3

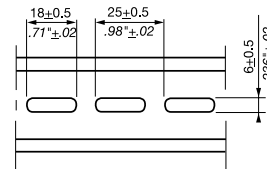
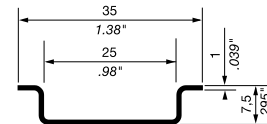

Type	P/N
PR30 (TS 35/F6)	0173 220.05
White passivated galvanized steel, prepunched length 2 m 6'6" (78") approx. The length and prepunched cut out dimensions are approximate.	

TS 35

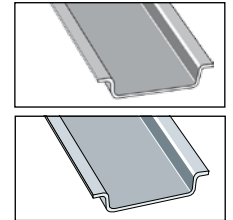

In compliance with EN 50022 standard (DIN 46277-3 - NFC 63015) DIN 3

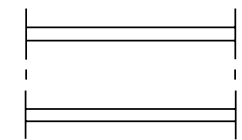
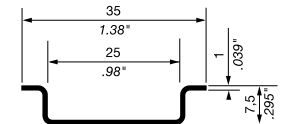

Type	P/N
PR3.Z2 (TS 35)	0174 300.17
White passivated galvanized steel, length 2 m 6'6" (78") approx.	

BA

End stops

The end stops are mounted at the extremity of the terminal board assembly, giving additional support to the terminal blocks as markers. For various types of marking, refer to the marker section

BADL

Screwless, snaps on rail without tool. V0 grey polyamide for DIN 3 rail. Maintained in place and locked on the rail with metal grips.

To reposition, do not slide on the rail. Withdraw and snap again (screwdriver DIA. 6,5 mm .256" max.)

Thickness : 9 mm .354"

BADL

0199 408.02

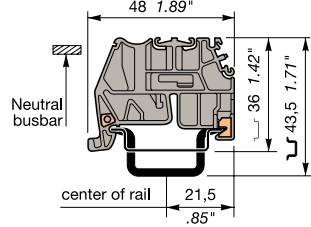
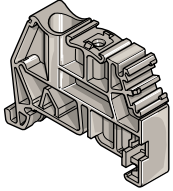

BAM2

End stop with screws DIN 3

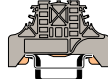

BAM2

light grey V0 BAM2 V0 10 mm

0399 967.01

grey V2 BAM2 10 mm

0206 351.16

beige V0 BAM2 V0 10 mm

0296 351.00

BAMH

Multi-rail end stop of V2 or V0 polyamide equipped with 2 blocking screws allows mounting on PR1, PR3, PR4 and PR5 (DIN 1, DIN 3) rails.

Suitable for double deck blocks.

Recommended screwdriver : DIA. 5,5 mm .217"

Recommended torque :

Min. 0,8 mN - Max. 1 mN

Min. 7.1 lb.in - Max. 8.9 lb.in

Thickness : 9,1 mm .358"

BAMH

0114 836.00

BAMH V0

0194 836.01

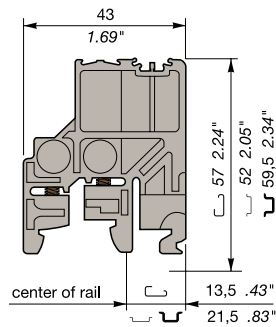

BAR

Reversible end stop of beige polyamide with blocking bracket. To be mounted vertically or at 30° angle, on PR1 rail only.

Thickness : 10 mm .394"

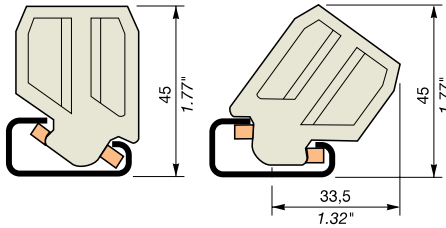

BAR beige

0164 519.24

BADH, BAEH

Tall end stop of polyamide, for use with M 70/22, M 95/26 blocks, power blocks, double or triple deck blocks, and electronic interface modules series 7000, 8000, 10000, 11000 and 30000. Snaps on rail - Easy mounting and repositioning, even between 2 blocks.

Recommended screwdriver : DIA. 5,5 mm .217"

Recommended torque : Min. 1,2 Nm - Max. 1,4 Nm

Min. 10.6 lb.in - Max. 12.3 lb.in

Thickness : 12 mm .472"

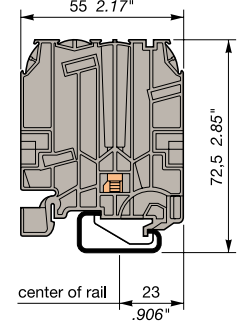
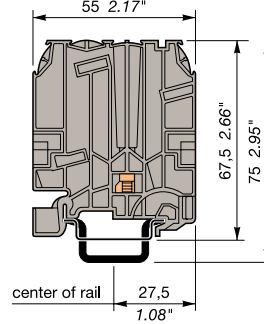
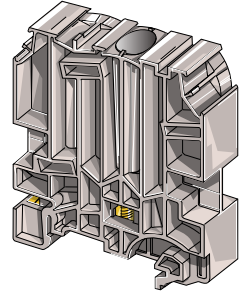

BADH grey

0116 900.27

BAEH grey

0116 934.04

BAEH beige

0196 934.05

Terminal blocks mounting

on PR1 rail

on PR3, PR30, PR4, PR5 rail

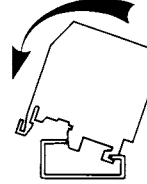

To be mounted vertically

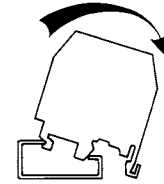

To be mounted at 30° angle
(only for screw-screw)

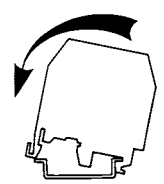

To be mounted vertically

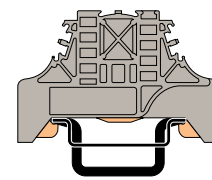

End stop with screws DIN 3

grey V0 BAM2 V0 10 mm

0399 967.01

blue V2 BAM2 10 mm

0206 351.16

beige V0 BAM2 V0 10 mm

0296 351.00

RC Standard marker cards

Marking method **5** **10**

Each marker card contains 10 strips of 10 markers, i.e. 100 markers per card. Marker cards are white polyamide 6 moulding with black lettering.

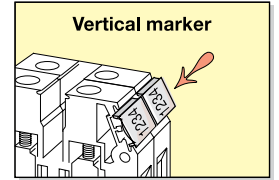
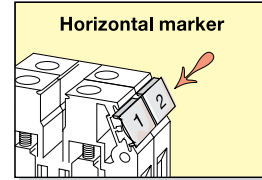

How to use

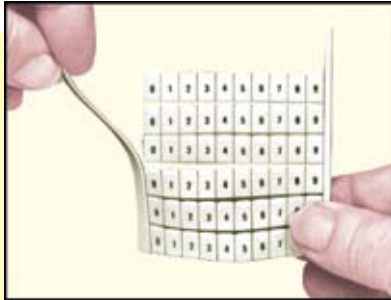

1

Remove one of the side bands of the card.

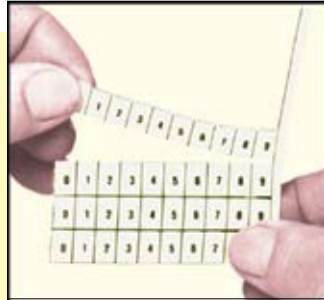

2

Separate the chosen strip from the rest of the card.



3

- Marking with strips of 10 markers for blocks with 5.6 and 8 mm spacing: Press the first marker in place, hold it, and press the rest of the strip with your thumb.
- Single markers: Press the chosen marker in place, hold it, and tear off the rest of the strip.

Marker sizes

RC55
5 x 5 mm .197" x .197" markers.
Can be used on blocks from 5 mm .197" spacing, with possibility of mounting 1 or 2 markers per housing.

RC510
5 x 10 mm .197" x .395" markers.
Can be used on blocks from 5 mm .197" spacing, with possibility of mounting 1 markers per housing.

Blank card

Blank marker cards

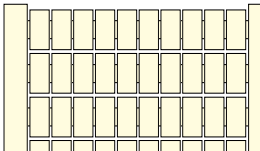

RC55	RC510
0230 000.12	0231 000.07

Horizontal marking of numbers

Horizontal marking
Increasing order

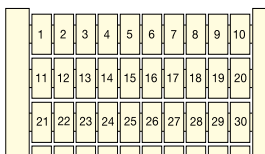

	RC55	RC510
1 → 100	0230 030.07	0231 030.24
101 → 200	0230 031.24	0231 031.11
201 → 300	0230 032.25	0231 032.12
301 → 400	0230 033.26	0231 033.13
401 → 500	0230 034.27	0231 034.14
501 → 600	0230 035.20	0231 035.15
601 → 700	0230 036.21	0231 036.16
701 → 800	0230 037.22	0231 037.17
801 → 900	0230 038.03	0231 038.20
901 → 1000	0230 039.04	0231 039.21
1001 → ...	0230 071.04	0231 071.21

Horizontal marking Repeated increasing order 10 times

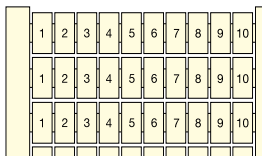

0 → 9
1 → 10
11 → 20
21 → 30
31 → 40
41 → 50
51 → 60
61 → 70
71 → 80
81 → 90
91 → 100
101 → 110
111 → 120
121 → 130
131 → 140
141 → 150
151 → 160
161 → 170
171 → 180
181 → 190
191 → 200
201 → ...
... → 999

RC55	RC510
0230 001.07	0231 001.24
0230 002.00	0231 002.25
0230 003.01	0231 003.26
0230 004.02	0231 004.27
0230 005.03	0231 005.20
0230 006.04	0231 006.21
0230 007.05	0231 007.22
0230 008.16	0231 008.03
0230 009.17	0231 009.04
0230 010.03	0231 010.20
0230 011.20	0231 011.15
0230 012.21	0231 012.16
0230 013.22	0231 013.17
0230 014.23	0231 014.10
0230 015.24	0231 015.11
0230 016.25	0231 016.12
0230 017.26	0231 017.13
0230 018.07	0231 018.24
0230 019.00	0231 019.25
0230 020.05	0231 020.22
0230 021.22	0231 021.17

0230 022.23* 0231 022.10*

Horizontal marking of numbers

Horizontal marking
Alternate even/odd numbered for 2 deck block M 4/6.D

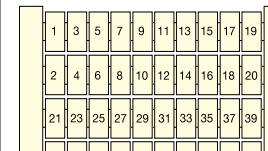

	RC55	RC510
1 → 20	0232 133.15	0233 133.16
21 → 40	0232 134.16	0233 134.17
41 → 60	0232 135.17	0233 135.10
61 → 80	0232 136.10	0233 136.11
81 → 100	0232 137.11	0233 137.12

Horizontal marking of conventional symbols

Horizontal marking
Repeated identical symbols



	RC55	RC510
100 x +	0230 111.21	0231 111.16
100 x -	0230 112.22	0231 112.17
100 x ~	0230 114.24	0231 114.11
100 x =	0230 113.23	0231 113.10
100 x	0230 115.25	0231 115.12

* Part number identical for each group of numbers - On request indicate marking

Horizontal marking of letters

Horizontal marking
Repeated identical letters

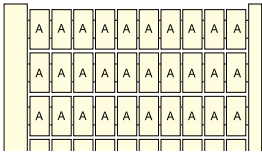

	RC55	RC510
100 x A	0230 150.14	0231 150.01
100 x B	0230 151.01	0231 151.26
100 x C	0230 152.02	0231 152.27
100 x D	0230 153.03	0231 153.20
100 x E	0230 154.04	0231 154.21
100 x F	0230 155.05	0231 155.22
100 x G	0230 156.06	0231 156.23
100 x H	0230 157.07	0231 157.24
100 x I	0230 158.10	0231 158.05
100 x J	0230 159.11	0231 159.06
100 x K	0230 160.16	0231 160.03
100 x L	0230 161.03	0231 161.20
100 x M	0230 162.04	0231 162.21
100 x N	0230 163.05	0231 163.22
100 x O	0230 164.06	0231 164.23
100 x P	0230 165.07	0231 165.24
100 x Q	0230 166.00	0231 166.25
100 x R	0230 167.01	0231 167.26
100 x S	0230 168.12	0231 168.07
100 x T	0230 169.13	0231 169.00
100 x U	0230 170.10	0231 170.05
100 x V	0230 171.05	0231 171.22
100 x W	0230 172.06	0231 172.23
100 x X	0230 173.07	0231 173.24
100 x Y	0230 174.00	0231 174.25
100 x Z	0230 175.01	0231 175.26

Vertical marking of numbers

Vertical marking
Increasing order repeated 10 times

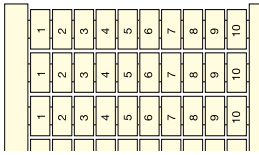

	RC55	RC510
0 → 9	0230 040.11	0231 040.06
1 → 10	0230 041.06	0231 041.23
11 → 20	0230 042.07	0231 042.24
21 → 30	0230 043.00	0231 043.25
31 → 40	0230 044.01	0231 044.26
41 → 50	0230 045.02	0231 045.27
51 → 60	0230 046.03	0231 046.20
61 → 70	0230 047.04	0231 047.21
71 → 80	0230 048.15	0231 048.02
81 → 90	0230 049.16	0231 049.03
91 → 100	0230 050.13	0231 050.00
101 → 110	0230 051.00	0231 051.25
111 → 120	0230 052.01	0231 052.26
121 → 130	0230 053.02	0231 053.27
131 → 140	0230 054.03	0231 054.20
141 → 150	0230 055.04	0231 055.21
151 → 160	0230 056.05	0231 056.22
161 → 170	0230 057.06	0231 057.23
171 → 180	0230 058.17	0231 058.04
181 → 190	0230 059.10	0231 059.05
191 → 200	0230 072.05	0231 072.22
201 → ...	0230 073.06*	0231 073.23*
... → 999		

*Reference identical for each group of numbers
-on request indicate marking.
Ex: 0230 073.06 : 301 to 310

Vertical marking of symbols

Vertical marking
Repeated identical symbols



	RC55	RC510
100 x A	0230 180.03	0231 180.20
100 x B	0230 181.20	0231 181.15
100 x C	0230 182.21	0231 182.16
100 x D	0230 183.22	0231 183.17
100 x E	0230 184.23	0231 184.10
100 x F	0230 185.24	0231 185.11
100 x G	0230 186.25	0231 186.12
100 x H	0230 187.26	0231 187.13
100 x I	0230 188.07	0231 188.24
100 x J	0230 189.00	0231 189.25
100 x K	0230 190.05	0231 190.22
100 x L	0230 191.22	0231 191.17
100 x M	0230 192.23	0231 192.10
100 x N	0230 193.24	0231 193.11
100 x O	0230 194.25	0231 194.12
100 x P	0230 195.26	0231 195.13
100 x Q	0230 196.27	0231 196.14
100 x R	0230 197.20	0231 197.15
100 x S	0230 198.01	0231 198.26
100 x T	0230 199.02	0231 199.27
100 x U	0230 200.27	0231 200.14
100 x V	0230 201.14	0231 201.01
100 x W	0230 202.15	0231 202.02
100 x X	0230 203.16	0231 203.03
100 x Y	0230 204.17	0231 204.04
100 x Z	0230 205.10	0231 205.05

Vertical marking
Increasing order

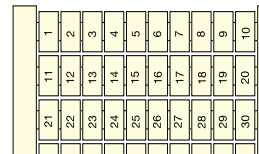

	RC55	RC510
1 → 100	0230 060.15	0231 060.02
101 → 200	0230 061.02	0231 061.27
201 → 300	0230 062.03	0231 062.20
301 → 400	0230 063.04	0231 063.21
401 → 500	0230 064.05	0231 064.22
501 → 600	0230 065.06	0231 065.23
601 → 700	0230 066.07	0231 066.24
701 → 800	0230 067.00	0231 067.25
801 → 900	0230 068.11	0231 068.06
901 → 1000	0230 069.12	0231 069.07
1001 → ...	0230 070.17*	0231 070.04*

* Reference identical for each group of numbers
-on request indicate marking.
Ex: 0230 070.17 : 1001 to 1100

Other marking methods are possible: consult us or refer to "Product guide" catalog.