

Central Units  
07 KT 93 R101 and R171

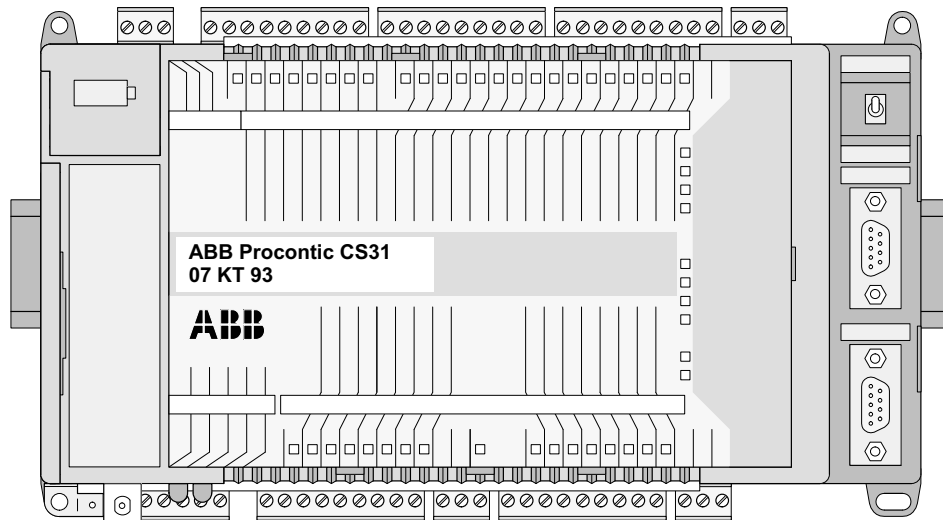

## **Regulations Concerning the Setting up of Installations**

Apart from the basic "Regulations for the Setting up of Power Installations" DIN VDE\* 0100 and for "The Rating of Creepage Distances and Clearances" DIN VDE 0110 Part 1 and Part 2 the regulations "The Equipment of Power Installations with Electrical Components" DIN VDE 0160 in conjunction with DIN VDE 0660 Part 500 have to be taken into due consideration.

Further attention has to be paid to DIN VDE 0113 Part 1 and Part 200 in case of the control of working and processing machines. If operating elements are to be mounted near parts with dangerous contact voltage DIN VDE 0106 Part 100 is additionally relevant.

If the protection against direct contact according to DIN VDE 0160 is required, this has to be ensured by the user (e.g. by incorporating the elements in a switch-gear cabinet). The devices are designed for pollution severity 2 in accordance with DIN VDE 0110 Part 1. If higher pollution is expected, the devices must be installed in appropriate housings.

The user has to guarantee that the devices and the components belonging to them are mounted following these regulations. For operating the machines and installations, other national and international relevant regulations, concerning prevention of accidents and using technical working means, also have to be met.

The ABB Procontic devices are designed according to IEC 1131 Part 2. Meeting this regulation, they are classified in overvoltage category II which is in conformance with DIN VDE 0110 Part 2.

For the direct connection of ABB Procontic devices, which are powered with or coupled to AC line voltages of overvoltage category III, appropriate protection measures corresponding to overvoltage category II according to IEC-Report 664/1980 and DIN VDE 0110 Part 1 are to install.

Equivalent standards:

DIN VDE 0110 Part 1  $\triangleq$  IEC 664

DIN VDE 0113 Part 1  $\triangleq$  EN 60204 Part 1

DIN VDE 0660 Part 500  $\triangleq$  EN 60439-1  $\triangleq$  IEC 439-1

All rights reserved to change design, size, weight, etc.

\* VDE stands for "Association of German Electrical Engineers".

ABB Schalt- und Steuerungstechnik GmbH Heidelberg

### 3

## Central unit 07 KT 93

Central unit with max. 56 kB user program + 30 kB user data

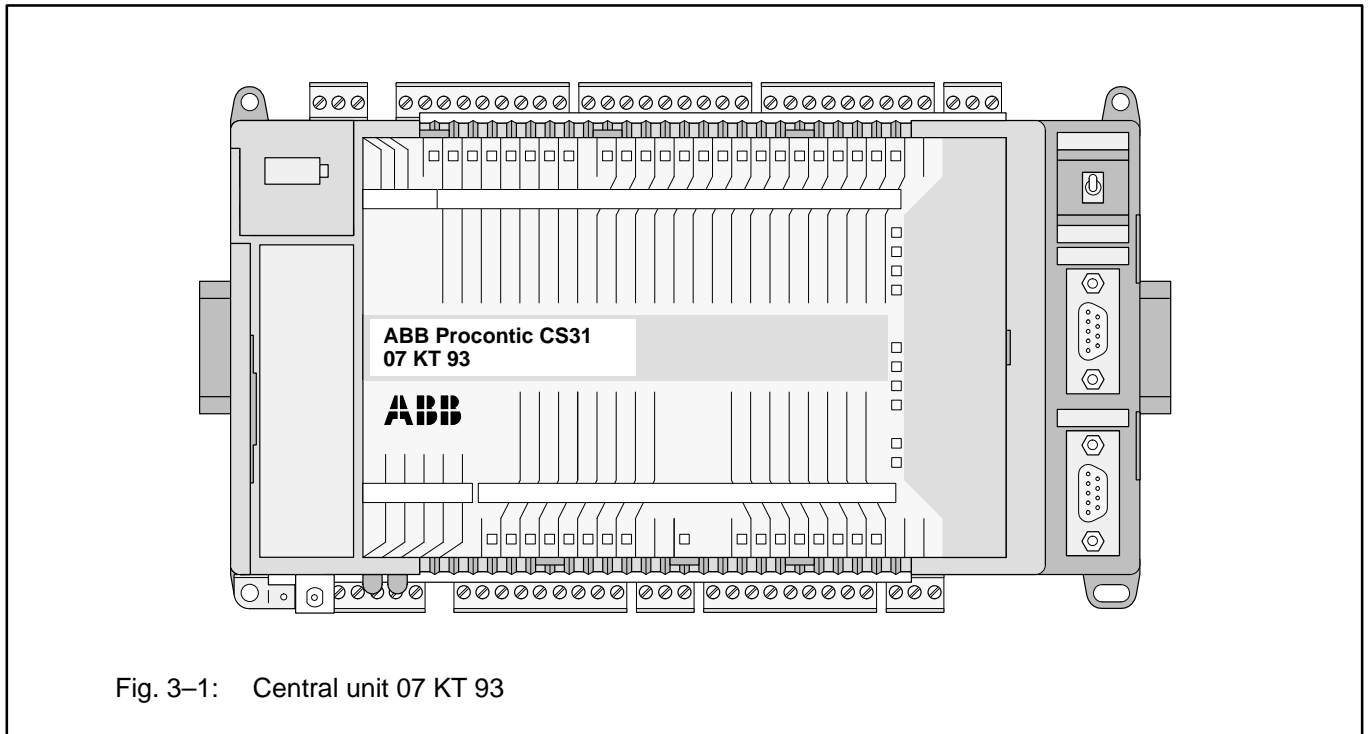

Fig. 3–1: Central unit 07 KT 93

### Contents

<b>3.1</b>	<b>Brief description</b> .....	3– 2	3.3.11	Serial interface COM2 .....	3–14
3.1.1	Main features .....	3– 2	3.3.12	Networking interface .....	3–15
3.1.2	Project planning/start-up .....	3– 2	<b>3.4</b>	<b>High-speed counter</b> .....	3–16
<b>3.2</b>	<b>Structure of the front panel</b> .....	3– 4	<b>3.5</b>	<b>Technical data</b> .....	3–19
3.2.1	Terminal assignment overview .....	3– 5	3.5.1	General data .....	3–19
<b>3.3</b>	<b>Electrical connection</b> .....	3– 6	3.5.2	Power supply .....	3–20
3.3.1	Application example for input and output wiring .....	3– 6	3.5.3	24 V output voltage for the supply of inputs .....	3–20
3.3.2	Connecting the supply voltage .....	3– 7	3.5.4	Lithium battery .....	3–20
3.3.3	Electrical isolation and notes on earthing .....	3– 8	3.5.5	Binary inputs .....	3–20
3.3.4	ARCnet interface .....	3– 9	3.5.6	Binary outputs .....	3–21
3.3.5	Connection for ABB Procontic CS31 system bus .....	3– 9	3.5.7	Connection of serial interface COM1 ..	3–21
3.3.6	24 V output voltage for the signal supply of the inputs .....	3–10	3.5.8	Connection of serial interface COM2 ..	3–22
3.3.7	Connection of the binary inputs .....	3–10	3.5.9	Connection to the ABB Procontic CS31 system bus .....	3–22
3.3.8	Connection of the binary outputs .....	3–11	3.5.10	Connection to ARCnet .....	3–22
3.3.9	Battery and battery replacement .....	3–12	3.5.11	LED displays .....	3–23
3.3.10	Serial interface COM1 .....	3–13	3.5.12	High-speed hardware counter .....	3–23
			3.5.13	Mechanical data .....	3–24
			3.5.14	Mounting hints .....	3–24
			3.5.15	Ordering data .....	3–25

### 3.1 Brief description

The central unit 07 KT 93 works either as

- bus master in the decentralized automation system ABB Procontic CS31 or as
- slave (remote processor) in the decentralized automation system ABB Procontic CS31 or as
- stand-alone central unit.

The device has a 24 V DC power supply voltage. It is provided with an additional interface for connecting communication modules (e.g. 07 KP 90).

The central unit 07 KT 93 R171 is equipped with an **integrated ARCnet coupler** (and an ARCnet interface).

#### 3.1.1 Main features

- 24 binary inputs
- 16 binary transistor outputs
- 1 counting input for counting frequencies up to 10 kHz
- 1 CS31 system bus interface for system expansion
- Serial interface COM1
  - is set as programming interface
  - can be set as an ASCII interface for connecting peripheral devices (e.g. MMC devices)
- Serial interface COM2 as an MMC interface
- ARCnet coupler / ARCnet interface (version R171 only)
- Real-time clock
- LEDs for displaying the binary input and output signals as well as operating conditions and error messages
- Detachable screw-type terminal blocks
- Detachable plastic sheet on the front side of the device; can be labelled with the signal names in order to have the inputs and outputs directly assigned
- Fastening by screws or by snapping the device onto a DIN rail
- The lithium battery 07 LE 90 can be put into the battery compartment in order to
  - store and back-up the user program in the RAM
  - store and back-up data which is additionally contained in the RAM, e.g. the status of flags
  - back-up the time and date (real-time clock)
- RUN/STOP switch for starting and aborting the program execution.

- Extensive diagnosis functions
  - Self-diagnosis of the central unit
  - Diagnosis of the ABB Procontic CS31 system bus and the connected modules

#### 3.1.2 Project planning / start-up

The following has to be observed for project planning and start-up:

- Programming is performed using ABB Procontic programming software, which can be run on commercially available IBM compatible PCs (see documentation for the programming system 907 PC 331)
- Diagnosis and service device TCZ (terminal mode) (see volume 7.3, see chapter A5 (Appendix), Programming and test, see 3.3.10 Serial interface COM1)
- The processor processes the user program contained in the RAM. It is loaded into the RAM via the serial interface COM1 and can also be changed there. An additional save command is used to save the program in the Flash EPROM.

Note: In the course of the following operations

- Power 'ON'
- RUN/STOP switch from STOP → RUN
- Program start-up with programming system
- Cold start of the PLC

the RAM is overwritten by the contents of the Flash EPROM, if a user program is contained in the Flash EPROM.

- On-line program modification  
The two existing RAMs allow a quick modification of the user program to be performed without interrupting the operation (see ABB programming system 907 PC 331).
- Change-over between the application modes
  - Stand-alone central unit
  - Bus master central unit and
  - Slave central unit

The central unit is set to "Stand-alone" upon delivery. Changing the application mode is carried out in the following three steps:

1. Change the system constant KW 0,0 in the PLC, see chapter A7.3 (Appendix), System constants
2. Save the user program in the Flash EPROM
3. Activate new application mode by:
  - calling up the menu item of "Enable PLC mode" in the ABB programming and test system or
  - performing a warm start or
  - performing a cold start.

- Setting the cycle time  
see chapter A1 (Appendix), Processing times
- Addressing when remote modules are connected  
see chapter A2 (Appendix), Addressing
- Back-up of data areas  
Back-up of data areas, i.e. saving of data during power OFF/ON, is only feasible with built-in battery. The following data can be backed, completely or partly:

- Binary flags
- Word flags
- Double word flags
- Step chains
- Historical values

In order to back-up certain data, they have to be excluded from initialization to 0.

- Initialization of data areas  
During *program start*, that data areas are initialized to

0 partly or completely, that are defined by system constants, see chapter A7.3 (Appendix), System constants.

If no battery is effective or if the system constants are in their default values (factory settings), all of the above mentioned data areas are completely set to 0 after power OFF/ON.

- Reactions on errors of error class 3  
The user can configure whether or not the user program is to be aborted automatically, if an class 3 error occurs, see chapter A7.3 (Appendix), System constants.
- Starting-up the CS31 system after power ON  
The user can enter a number of  $n$  remote modules in KW 00,09. The user program starts only, i.e. it handles process inputs and outputs only, if at least  $n$  remote modules have been adopted into the CS31 system bus cycle, see chapter A7.3 (Appendix), System constants.

### 3.2 Structure of the front panel

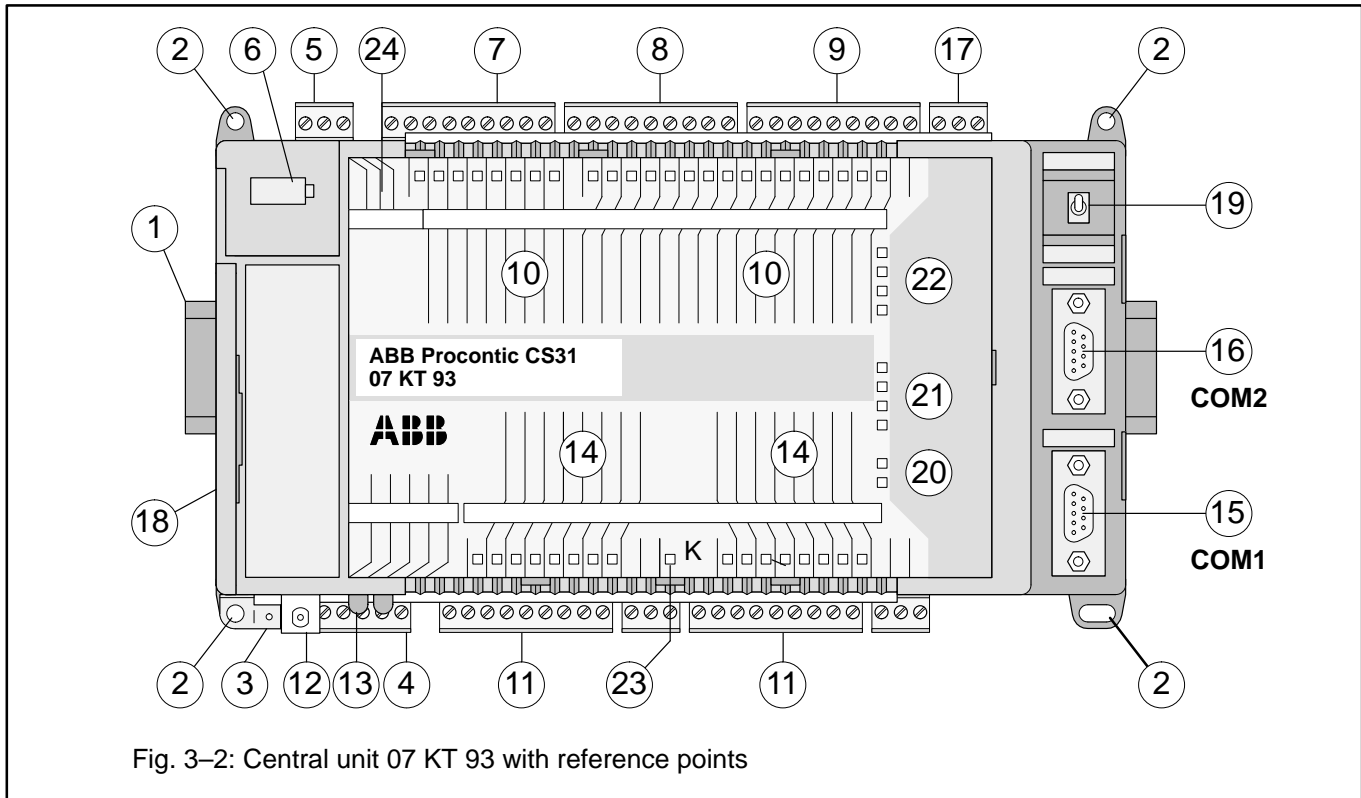



Fig. 3-2: Central unit 07 KT 93 with reference points

- ① Fastening of the device on DIN rail
- ② Fastening of the device by screws
- ③ Fasten earthing terminal 6.3 mm
- ④ Supply voltage connection 24 V DC
- ⑤ 24 V output voltage for input supply
- ⑥ Battery compartment
- ⑦-⑨ 24 binary inputs in three groups
- ⑩ Assignment of the identifiers for the inputs
- ⑪ 16 binary transistor outputs in two groups
- ⑫ ARCnet BNC connector (R171 only)
- ⑬ 2 LEDs for ARCnet operation (R171 only)
- ⑭ Assignment of the identifiers for the outputs
- ⑮ Serial interface COM1 (programming, MMC)
- ⑯ Serial interface COM2 (MMC)
- ⑰ Connection for ABB Procontic CS31 system bus
- ⑱ Cover of the interface for the connection of communication modules (may only be removed for connecting communication modules)
- ⑲ Switch for RUN/STOP operation
- ⑳ LEDs for supply voltage and battery
- ㉑ LEDs for RUN and error class
- ㉒ LEDs for CS31 system bus
- ㉓ LED for overload/short-circuit (LED K)
- Plastic sheet (detachable for labelling)

⑳	green	<input type="checkbox"/> <b>Supply</b>	Supply voltage available
	red	<input type="checkbox"/> <b>Battery</b>	Battery not effective
㉑	green	<input type="checkbox"/> <b>RUN</b>	User program is running
	red	<input type="checkbox"/> <b>FK1</b>	Fatal error
	red	<input type="checkbox"/> <b>FK2</b>	Serious error
	red	<input type="checkbox"/> <b>FK3</b>	Light error
㉒	green	<input type="checkbox"/> <b>BA</b>	Bus active
	red	<input type="checkbox"/> <b>BE</b>	Bus error
	red	<input type="checkbox"/> <b>RE</b>	Remote unit error
	red	<input type="checkbox"/> <b>SE</b>	Serial unit error

For further information see chapter A4.3 (App.) Troubleshooting by means of LED displays on the central unit

⑲

<b>RUN</b>

<b>STOP</b>

The RUN/STOP switch is used to start or abort the processing of the user program.

### 3.2.1 Terminal assignment overview

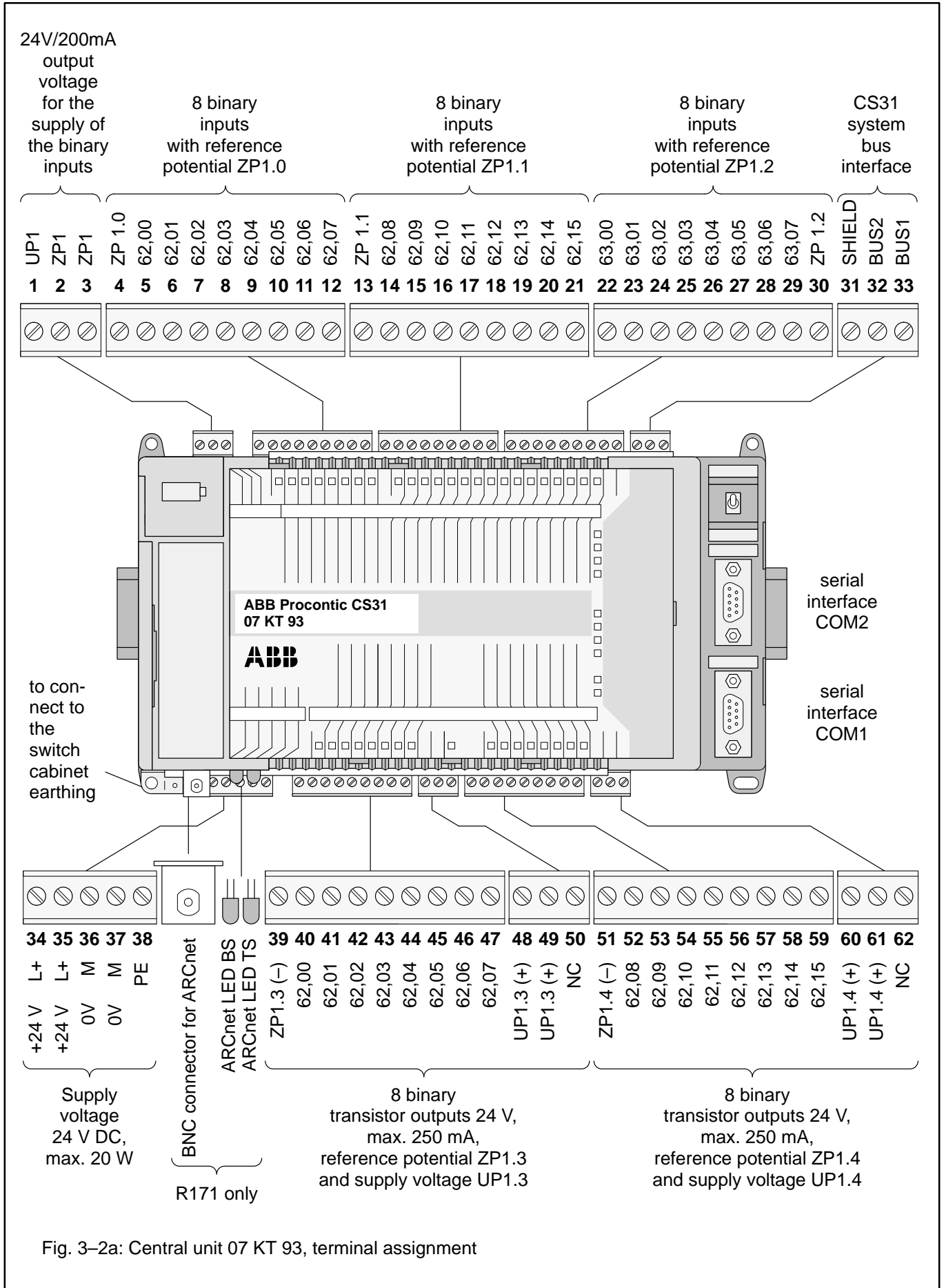

Fig. 3–2a: Central unit 07 KT 93, terminal assignment

### 3.3 Electrical connection

#### 3.3.1 Application examples for input and output wiring

The following illustration shows an application example in which different possibilities for wiring inputs and outputs are used.

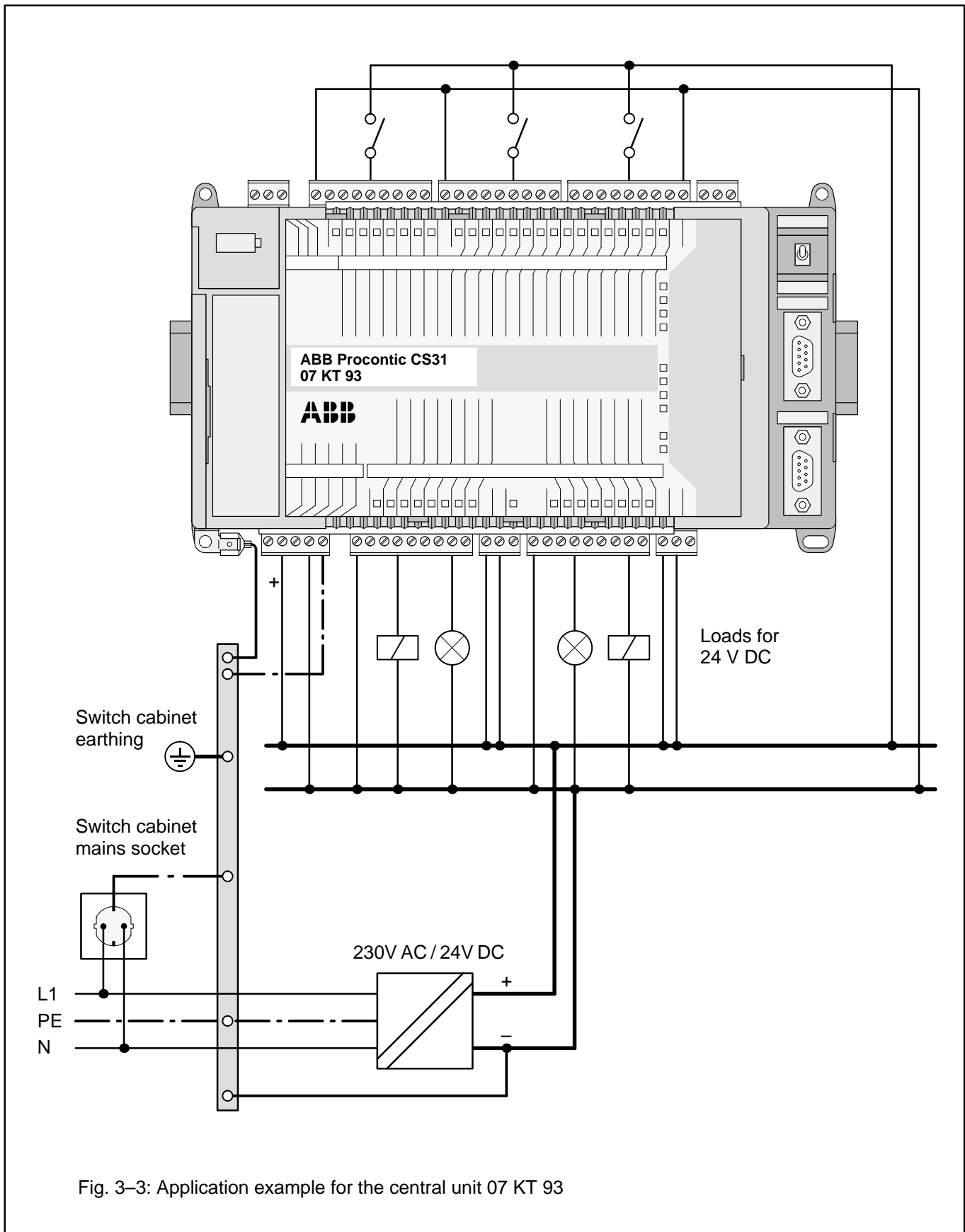

Fig. 3-3: Application example for the central unit 07 KT 93

Please observe in particular:

- The earthing measures
- The handling of the electrically isolated input groups
- The handling of the electrically isolated output groups
- The earthing of the switch cabinet mains socket

### 3.3.2 Connecting the supply voltage

The 24 V DC supply voltage is connected via a 5-pole detachable terminal block.

**Attention: Plug and unplug terminal block only with power is off!**

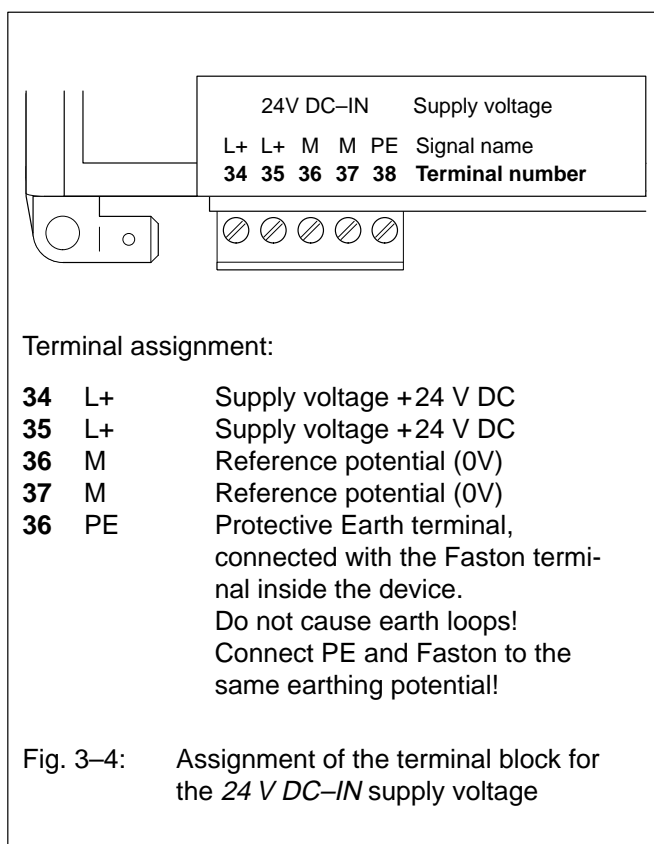

### 3.3.3 Electrical isolation and notes on earthing

The following illustration shows the parts of the device's circuit which are electrically isolated from each other as well as the internal connections which exist. Both the creepage distances and clearances as well as the test voltages used correspond to DIN/VDE 0160.

The 6.3 mm Faston terminal in the lower left corner has to be connected directly and on the shortest possible way to the switch cabinet earthing using a wire with a cross section of 6 mm<sup>2</sup> in order to ensure safe earthing and as an EMC measure.

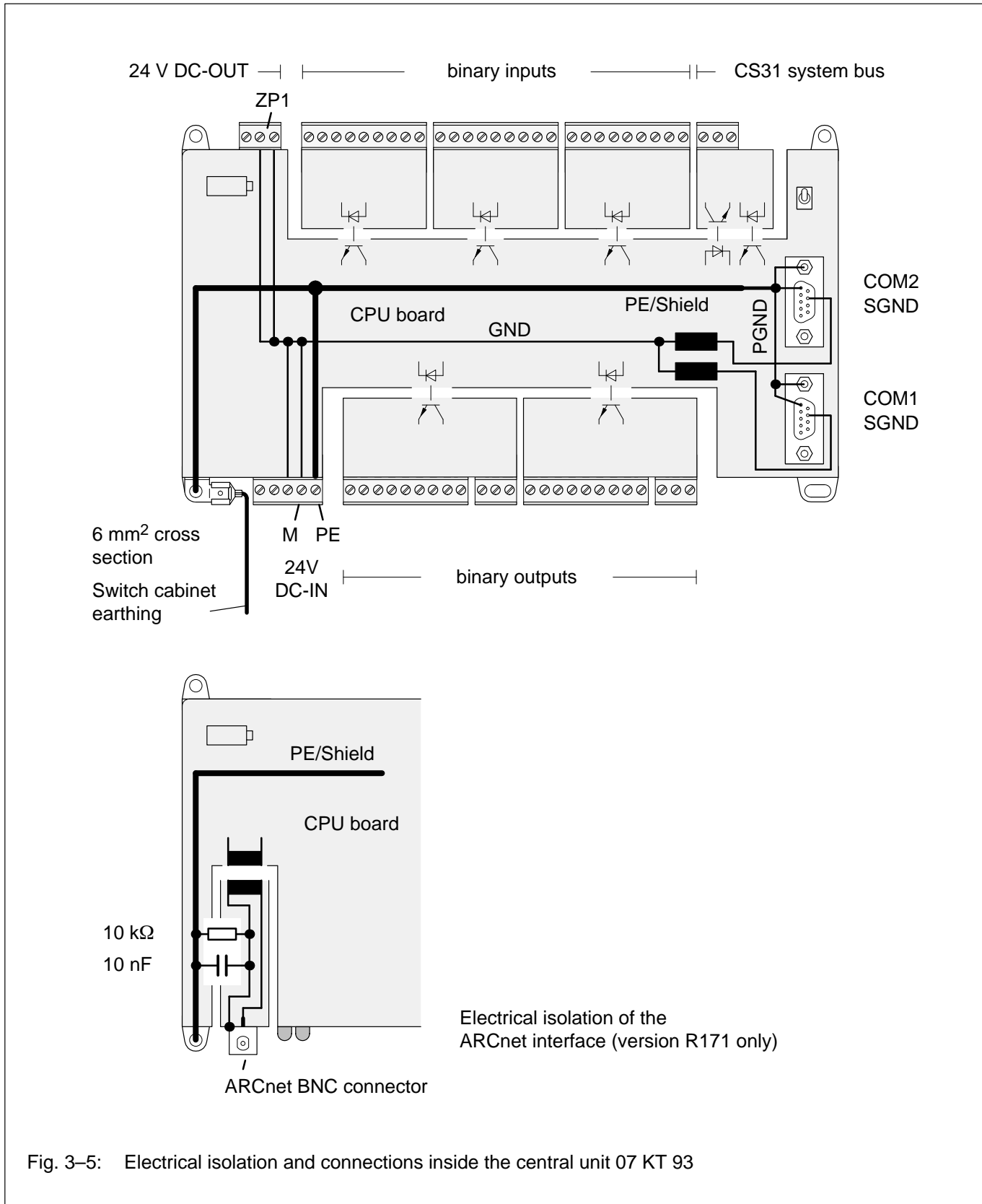
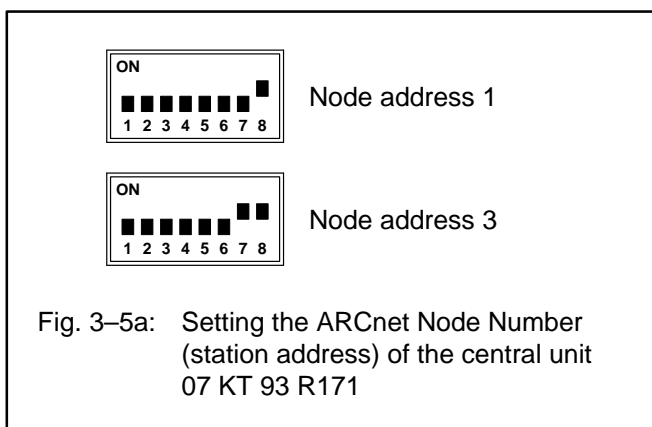

Fig. 3-5: Electrical isolation and connections inside the central unit 07 KT 93

### 3.3.4 ARCnet interface, see also chapter A8 (Appendix)

- The ARCnet coupler is integrated in the central unit 07 KT 93 **R171**. The DIL switch for setting the ARCnet address is accessible through the cutout of the external networking interface.
- The ARCnet coupler is supplied from the internal 24 V DC power supply.
- The function blocks AINIT, ASEND, AREC and APOLL are available for the ARCnet coupling.
- The data packages are read from the ARCnet controller interrupt-controlled. The interrupt routine stores the data package in the storage buffer. The APOLL block serves for the sending direction. It transfers data packages from the storage buffer to the ARCnet controller for sending them off.
- The ARCnet coupler interface is designed as a bus with BNC connector for coaxial cable. The ARCnet bus is earthed inside the module via a capacitor. As an EMC measure and for protection against dangerous contact voltages, the bus has to be earthed directly at a central place.
- Using the simplest configuration, called Linear ARCnet, a coaxial cable (RG62, 93 Ω) is layed from station to station and connected with T plugs at all stations. At both ends of the cable, termination resistors with 93 Ω each have to be installed, for more information see chapter A8.1 (Appendix). In a Linear ARCnet, a maximum of 8 stations is possible at a cable length of 300 m.
- The parallel networking interface is used for the ARCnet coupler inside the module. However, it is still available from outside as an external networking interface. The serial interface module 07 KP 92 can be connected here, for instance.

#### Setting the ARCnet Node Number (station address) of the central unit



### 3.3.5 Connection for ABB Procontic CS31 system bus

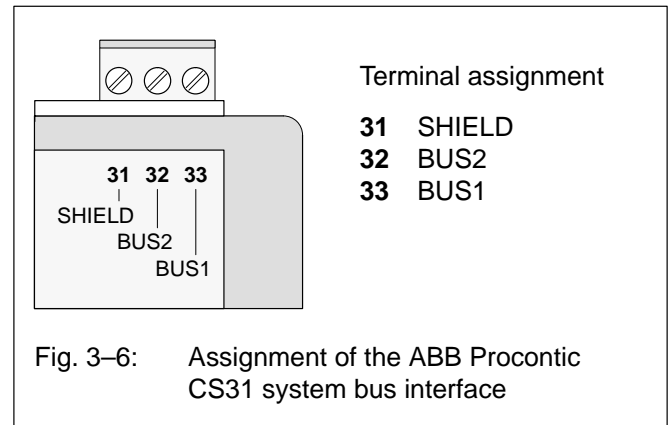

The connection to the ABB Procontic CS31 system bus is made by means of a 3-pole detachable terminal block. Please observe:

- All of the CS31 devices, no matter whether they are master or slave devices, are connected with the twisted-pair bus line as follows:
  - One core of the bus line is looped through via the BUS1 terminals of all devices to be connected to the CS31 system bus.
  - The other core of the bus line is looped through via the BUS2 terminals of all devices to be connected to the CS31 system bus.
- If the central unit 07 KT 93 is located at the beginning or at the end of the bus line, the bus terminating resistor (120 Ω) has to be connected additionally between the BUS1 and BUS2 terminals.
- The shield of the twisted-pair bus line is looped through via the SHIELD terminals of all the devices to be connected to the CS31 system bus.
- The handling of the CS31 system bus is described in detail in volume 2, System data.

### 3.3.6 24 V output voltage for the signal supply of the inputs

The central unit 07 KT 93 provides a separate 24 V DC voltage output for the supply of the 24 binary input signals (for this purpose only).

This 24 V output voltage is used only if an external 24 V DC power supply unit is not available.

The internal 24 V power supply is overload-proof. The 24 V output voltage is ready for operation again approx. 2 minutes after an overload has been eliminated.

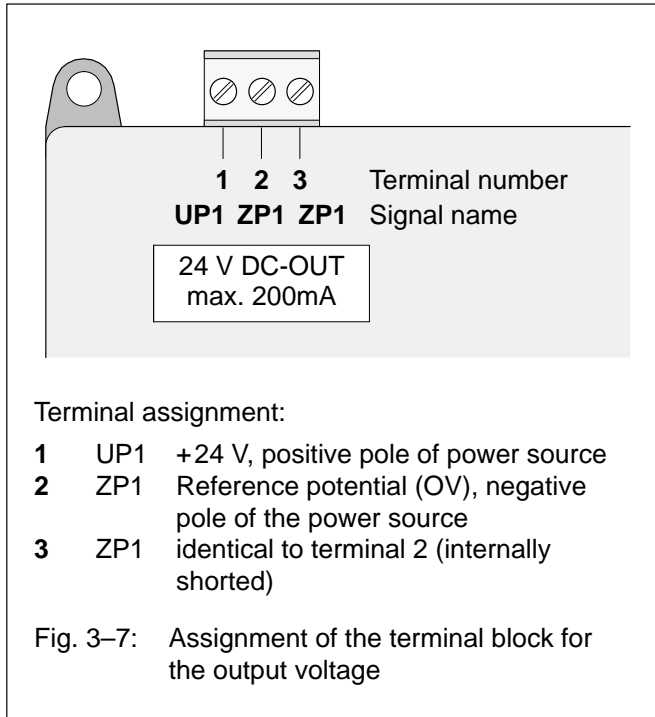

### 3.3.7 Connection of the binary inputs

The following illustration shows the circuit configuration of the binary inputs of the first group as an example.

Features:

- The 24 binary inputs are arranged in three groups.
- The three groups E 62,00...E 62,07, E 62,08...E 62,15 and E 63,00...E 63,07 are electrically isolated from each other (see Fig. 3–5).
- The inputs use 24 V signals in positive logic ( $1 \triangleq +24 \text{ V}$ ).

## Input signals at the terminals 5 and 6

### Terminal 5

#### – Use as normal input signal:

The signal is available in the user program in the operand E 62,00. The signal delay time is 2.5 ms.

The updating of the operand E 62,00 is performed before the start of each program cycle.

#### – Use as high-speed input signal:

The signal is available in the user program in the operand E 63,14. The signal delay time is 0.02 ms.

The updating of the operand E 63,14 is performed before the start of each program cycle.

In the Dual Port RAM (DPR) this signal is updated after each CS31 bus telegram. With the aid of the function block WOL this signal can be read in the Dual Port RAM (word address C000:1FEH, Bit 14).

#### – Use for the high-speed counter:

The signal is used as counting input (10 kHz) for the high-speed counter.

### Terminal 6

#### – Use as normal input signal:

The signal is available in the user program in the operand E 62,01. The signal delay time is 2.5 ms.

The updating of the operand E 62,01 is performed before the start of each program cycle.

#### – Use as high-speed input signal:

The signal is available in the user program in the operand E 63,15. The signal delay time is 0.02 ms.

The updating of the operand E 63,15 is performed before the start of each program cycle.

In the Dual Port RAM (DPR) this signal is updated after each CS31 bus telegram. With the aid of the function block WOL this signal can be read in the Dual Port RAM (word address C000:1FEH, Bit 15).

#### – Use for the high-speed counter:

The signal is used as enable input for the high-speed counter.

## Circuit configuration of the binary inputs of the first group as an example (E62,00...E 62,07)

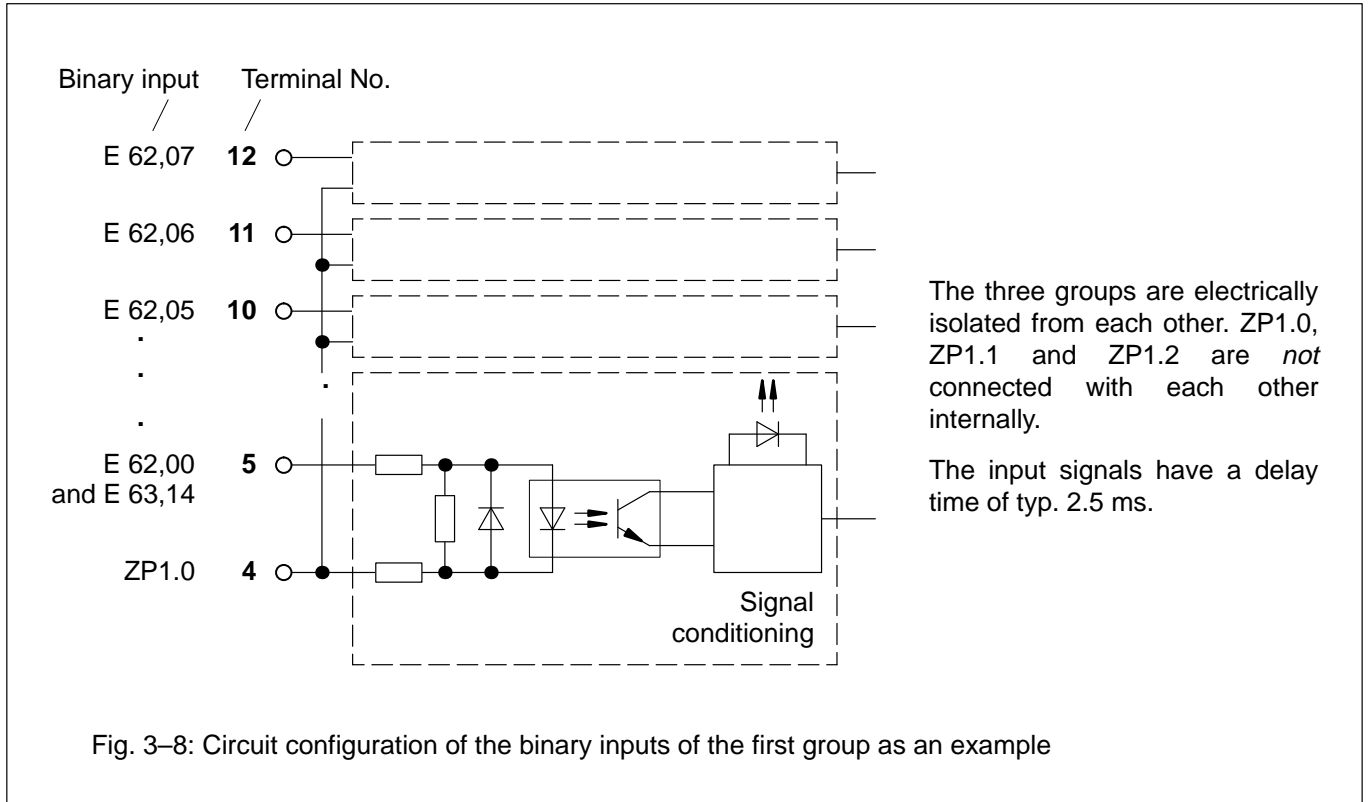

### 3.3.8 Connection of the binary outputs

The following illustration shows the circuit configuration of the binary outputs.

Features of the outputs:

- The 16 outputs are arranged in two groups. Within one group, the outputs are not electrically isolated from each other.
- The outputs can be loaded with a rated current of 250 mA.
- Each group as a whole is electrically isolated from the rest of the device (see also Fig. 3–5).
- The outputs use transistors and are short-circuit-proof.
- The eight transistors of one group have a common power supply.
- The outputs are automatically switched off in case of overload or short-circuit.
- A overall error message indicates a short-circuit or an overload which has occurred on one or on several outputs.
- An overload is displayed by the red LED K and via error flags in the PLC.
- The user can set by means of a system constant whether the overloaded output is to be switched on again automatically by the PLC or whether it is to be switched on again by configuring within the PLC program, e.g. by means of the function blocks CS31QU or CS31CO. The default setting is the automatic reset of the outputs.
- The red LED K goes out when the overloaded output is switched on again after eliminating the overload.
- The acknowledgement of the error message, i.e. the resetting of the error flags, is done in correspondence with chapter A4.8 (Appendix), Acknowledgement of error messages in the central unit.

## Circuit configuration of the binary outputs of the first group as an example (A 62,00...A 62,07)

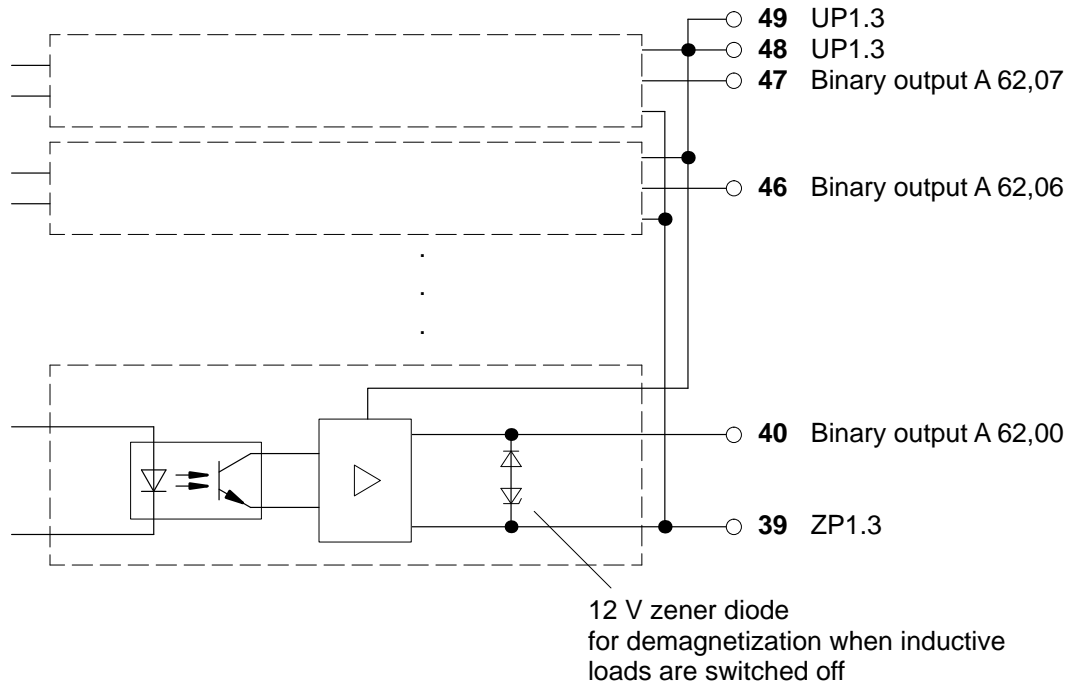
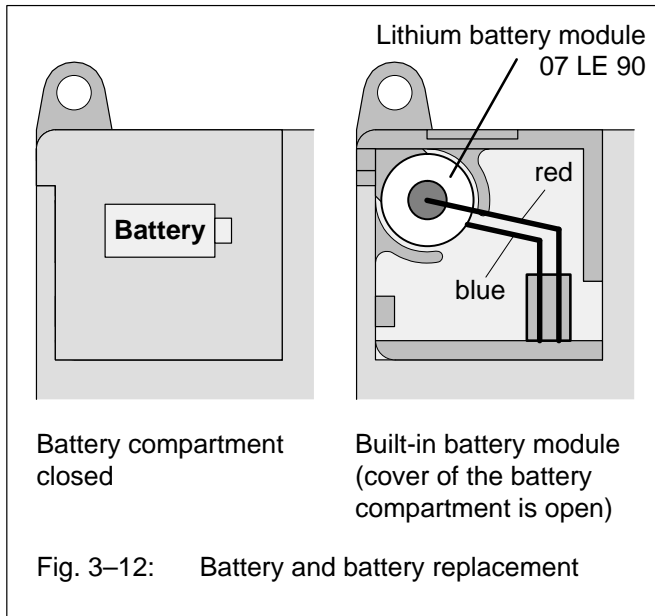

Fig. 3–11: Circuit configuration of the binary outputs of the first group as an example

### 3.3.9 Battery and battery replacement



- The lithium battery 07 LE 90 can be inserted into the battery compartment in order to
  - backup data of user program in RAM
  - backup data of additionally in RAM contained information, e.g. flag statuses
  - backup of time and date (real-time clock).

The battery lifetime is 1.5 years (typ. 3 years) at 25°C. The battery lifetime is the time during which the device remains operable in order to backup data while the supply voltage of the central unit is switched off. As long as there is a supply voltage available, there is no more load on the battery other than its own leakage current.

The following handling notes have to be observed:

- Use only lithium batteries approved by ABB.
- Replace the battery by a new one at the end of its life.
- **Never short-circuit the battery!**  
There is danger of overheating and explosion. Avoid accidental short-circuits, therefore do not store batteries in metallic containers or boxes and do not bring it into contact with metallic surfaces.
- **Never try to charge the battery!**  
Danger of overheating and explosion!
- **Replace the battery only with the supply voltage switched on!**  
Otherwise you risk data being lost.
- **Dispose of battery environmentally consciously!**
- If no battery is built-in or if the battery is exhausted, the red LED 'Battery' lights up.

### 3.3.10 Serial interface COM 1

Interface standard: EIA-232

#### Assignment of the serial interface COM1

The serial interface has the following pin assignment:

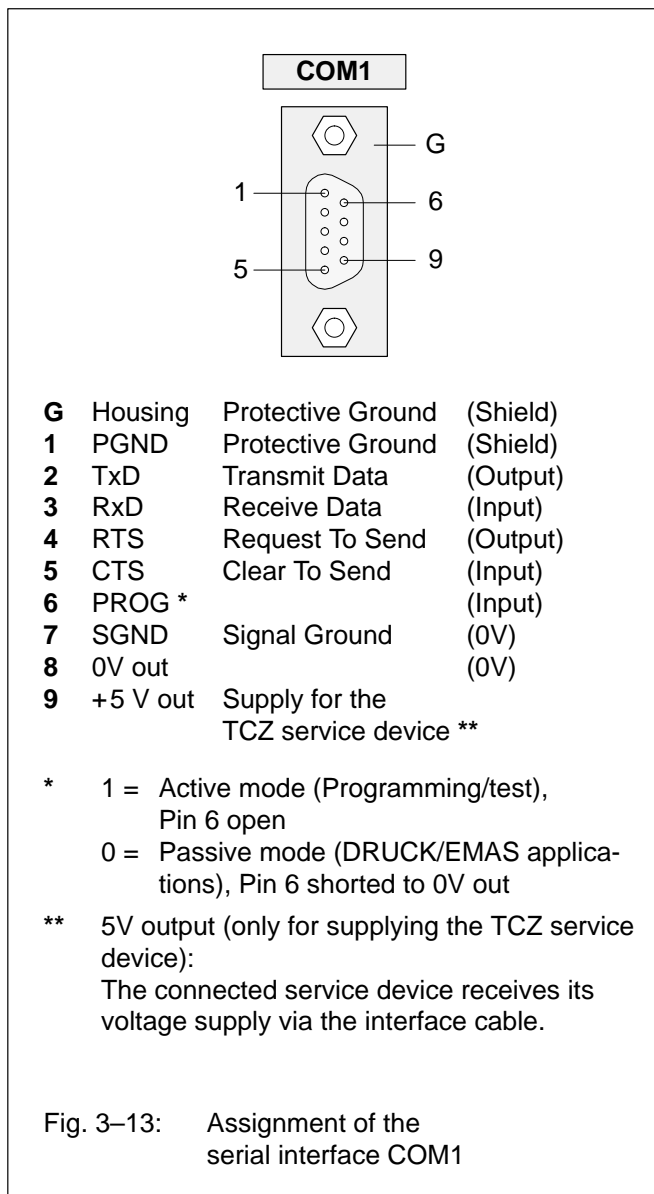

#### Operating modes of the serial interface COM1

The operating mode of the interface has to be set according to the application in each case:

- Programming and test or
- Man-machine-communication MMC

**Active mode:** The active mode is used for programming and testing the central unit, i.e. it gives the user access to all the programming and test functions of the central unit.

**Passive mode:** The passive mode is used to perform a communication configured with the DRUCK and EMAS blocks between the user program and a device connected to the serial interface.

#### Conditions for setting the operating modes of the interface COM1

RUN/STOP switch	System constant KW00,06	System cable/device	Mode set by this
STOP	x	x	Active
RUN	1	x	Active
	2	x	Passive
	0, <0, >2	07 SK 90	Active
		07 SK91, TCZ	Passive

x: without effect

#### Temporary interruption of the passive mode

While a communication between the DRUCK or EMAS blocks and a device connected to COM1 is being executed, it may be come necessary to modify the program, for example. For this purpose, you must switch over COM1 from the passive mode into the active mode.

#### Switch-over: Passive mode → Active mode

There are three possibilities for switching over:

- Set the RUN/STOP switch to the "STOP" position
- Replace cable 07 SK 91 by cable 07 SK 90 (if KW 00,06 is set to ≤0 or >2)
- Send the following special command to the PLC: <DEL><DEL><DEL>

The latter option has the advantage that the switch-over can also be controlled remotely, e.g. via telephone line and suitable dial-up modems. The ASCII character <DEL> has the decimal code of 127 and the hexadecimal code of 7FH. You can generate this character by simultaneously pressing the control key <CTRL> and the delete key <—>.

Notes:

On German keyboards, the control key is labelled by <Strg> instead of <CTRL>.

If the switch-over to the active mode was performed using the special command <DEL><DEL><DEL>, please observe the following:

*During the execution* of the PLC program, the system constant KW 00,06 must **not** be sent to the PLC because this would cause the system to be switched back to the passive mode.

The special command assigns the value of "1" to the image of the system constant KW 00,06 located in the operand memory. The PLC evaluates the value of this image and sets the kind of application of COM1 correspondingly.

### Switching back: Active mode → Passive mode

There are three possibilities for switching back:

- Return RUN/STOP switch to the "RUN" position
- Replace cable 07 SK 90 by cable 07 SK 91 again.
- Cancel the special command <DEL><DEL><DEL> as follows:
  - If the PLC program is in the "aborted" condition:  
*Start the PLC program.*
  - If the PLC program is in the "running" condition:  
*send the original value of the system constant KW 00,06 to the PLC again (907 PC 33 menu item "Send constants")*  
or  
*overwrite the system constant KW 00,06 by the original value (907 PC 33 menu item "overwriting")*

### Interface parameters

**Active mode:** The settings of the interface parameters cannot be changed

Data bits:	8
Stop bits:	1
Parity bits:	none
Baud rate:	9600
Synchronization:	RTS/CTS

**Passive mode:** Default setting

Synchronization:	RTS/CTS
Interface identifier COM1:	1
Baud rate:	9600
Stop bits:	1
Data bits:	8
Parity bits:	none
Echo:	off
Send Break Character:	0
Enabling End-of-text character for sending direction:	no <sup>1)</sup>
Sending End-of-text character:	<CR> <sup>1)</sup>
Receiving End-of-text character:	<CR> <sup>2)</sup>

<sup>1)</sup> The default End-of-text character for the sending direction (CR) is not sent. Nevertheless, this default End-of-text character (CR) must not appear in the message text of the assigned DRUCK block.

<sup>2)</sup> For the direction of reception, an End-of-text character is always necessary. This default End-of-text character (CR) must not appear neither in the message text nor in the user data of the assigned EMAS block.

For the passive mode of COM1, the interface parameters can be changed using the SINIT function block. If the changed values are not plausible, the COM1 interface uses the default values.

The interface is newly initialized each time the operating mode is switched over.

The active-mode parameters are set in the active mode, whereas in the passive mode the parameters established by the SINIT block or the default values are set.

### 3.3.11 Serial interface COM 2

**Interface standard:** EIA-232

#### Assignment of the serial interface COM2

The serial interface has the following pin assignment:

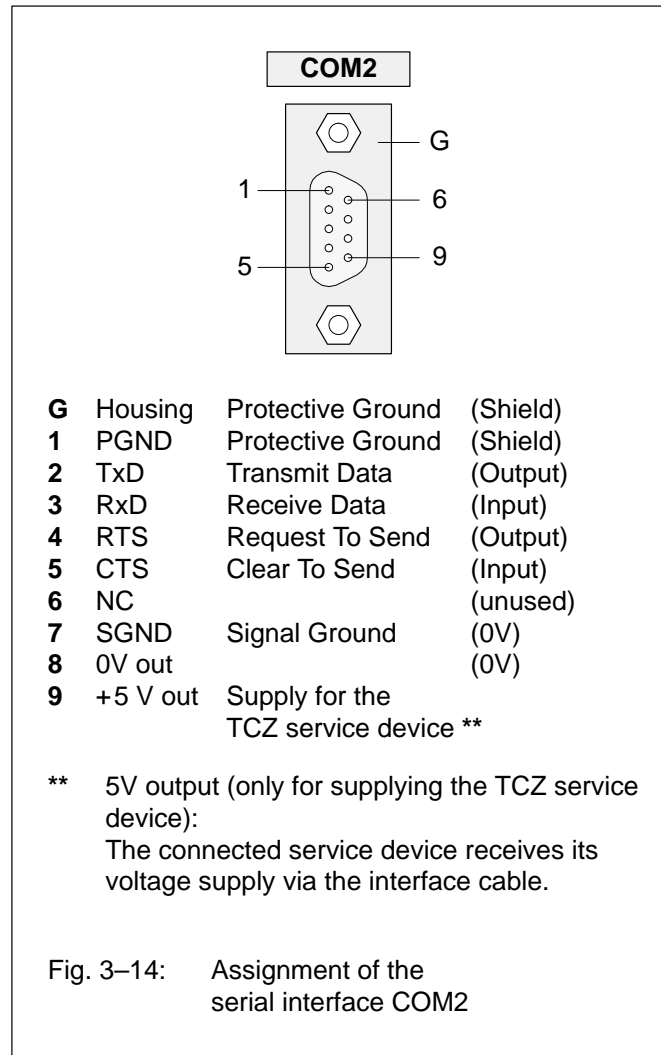

Fig. 3-14: Assignment of the serial interface COM2

## Operating modes of the COM2 interface

The serial interface COM2 is fixedly set to the **passive mode** (MMC interface).

The passive mode is used to perform a communication configured with the aid of the DRUCK and EMAS blocks between the user program and a device connected to the serial interface.

The application-specific initialization of COM2 can be performed using the SINIT function block.

### Interface parameter

Passive mode: Default setting

Synchronization:	RTS/CTS
Interface identifier COM2:	2
Baud rate:	9600
Stop bits:	1
Data bits:	8
Parity bits:	none
Echo:	off
Send Break Character:	0
Enabling End-of-text character for sending direction:	no <sup>1)</sup>
Sending End-of-text character:	<CR> <sup>1)</sup>
Receiving End-of-text character:	<CR> <sup>2)</sup>

- 1) The default End-of-text character for the sending direction (CR) is not sent. Nevertheless, this default End-of-text character (CR) must not appear in the message text of the assigned DRUCK block.
- 2) For the direction of reception, an End-of-text character is always necessary. This default End-of-text character (CR) must not appear neither in the message text nor in the user data of the assigned EMAS block.

For the passive mode of COM2, the interface parameters can be changed using the SINIT function block. If the changed values are not plausible, the COM2 interface uses the default values.

In the passive mode the parameters established by the SINIT block or the default values are set.

### 3.3.12 Networking interface

The 07 KT 93 central unit is equipped with a special parallel interface. It is thus possible to network it with another bus system using an additional communication processor module. The additional communication processor has its own housing. Both housings (of the 07 KT 93 and of the communication processor) are assembled by means of a snap-on connection.

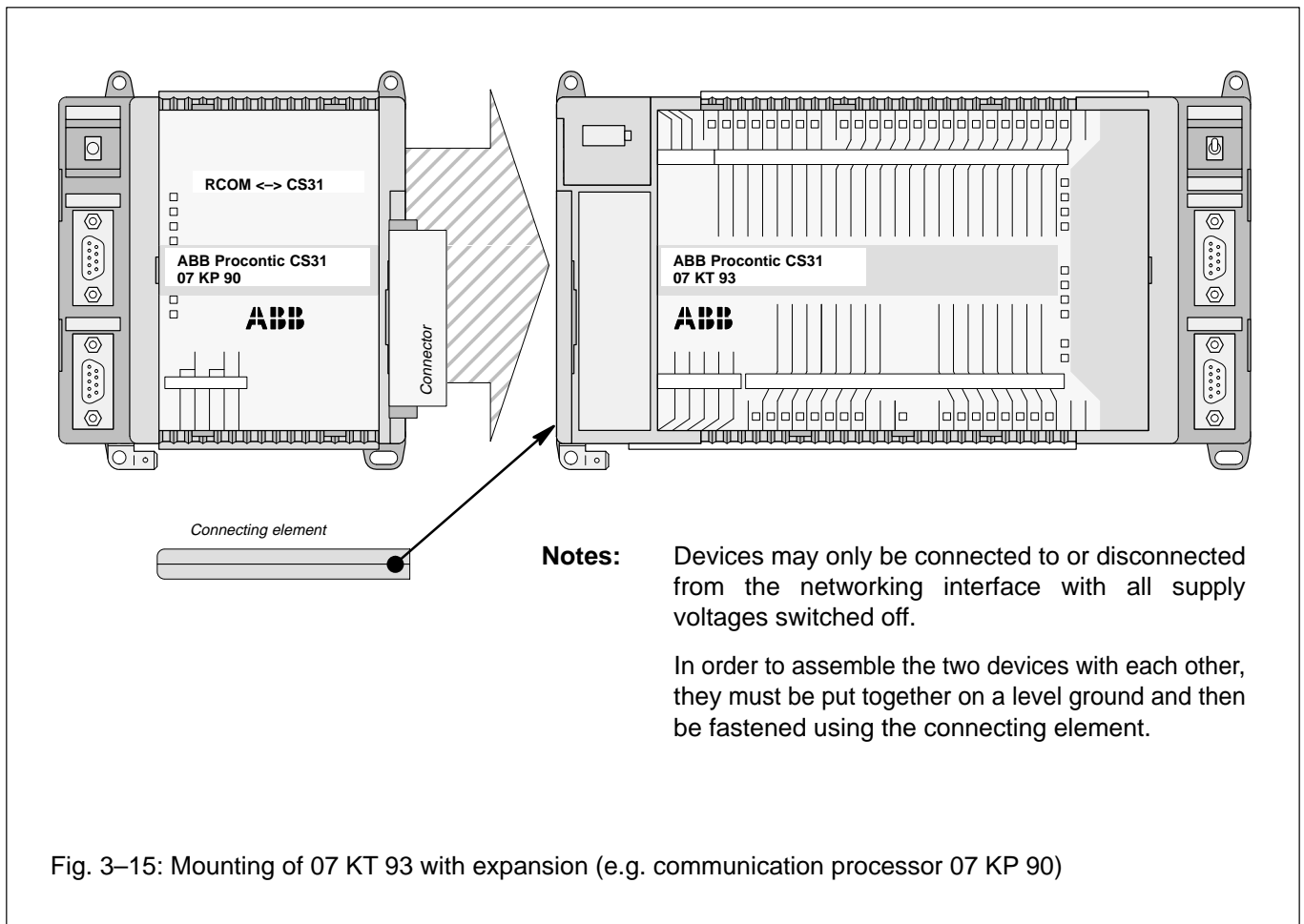

Fig. 3–15: Mounting of 07 KT 93 with expansion (e.g. communication processor 07 KP 90)

### 3.4 High-speed counter

#### Features

The high-speed counter used in the central units 07 KR 91, 07 KT 92 and 07 KT 93 works independently of the user program and is therefore able to response quickly to external signals. Its features are as follows:

- The counting frequency is max. 10 kHz. The counter counts the 0→1 edges at terminal 05 (also designated as E 62,00).
- The counter counts upwards from -32768 to +32767 (8000<sub>H</sub>...7FFF<sub>H</sub>). If +32767 is exceeded, the counter skips to -32768.

Sequence of the counting procedure:

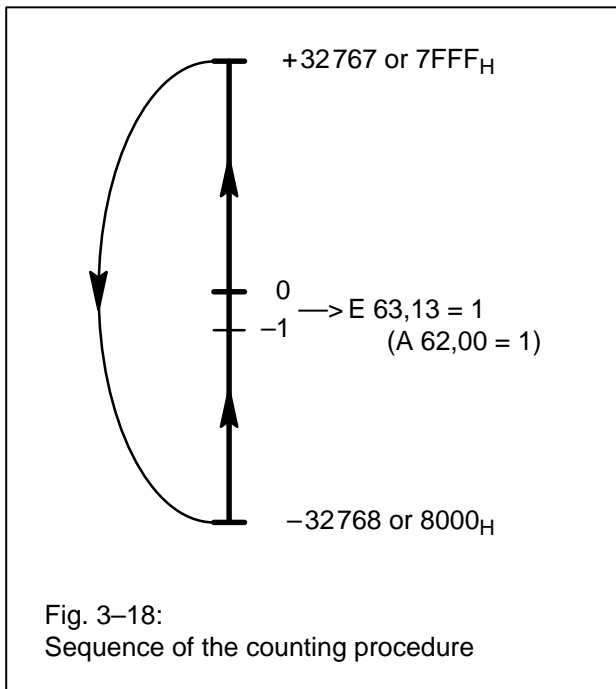

- Enabling/disabling of the counting procedure using the internal variable A 63,14 in the user program:
  - A 63,14 = 0:  
The internal variable A 63,13 = 1 enables the

counting procedure, whereas A 63,13 = 0 disables it.

- A 63,14 = 1:  
Signal 1 at terminal 06 (also designated as E 62,01) enables the counting procedure, whereas signal 0 disables it. A 63,13 is without effect.  
Note: The dead time may be 0...1.5 ms.

- Setting the counter in the user program:
  - to the value contained in the internal word variable AW 06,15
  - using the internal variable A 63,15 = 1.

Note: If the internal variable A 63,15 = 1 is present during several processing cycles, the processor sets the counter at the program end in each case. During the remaining time of the processing cycle, the counter counts pulses at terminal 05.

- The counter content can be read via the internal variable EW 06,15.
- Zero-crossing message (signal changes from 0 to 1 when the counter contents changes from -1 to 0):
  - always via the internal variable E 63,13,
  - at the terminal 40 (also designated as A 62,00) only, if the internal variable A 63,14 = 1 is set.  
Note: The reaction time may be 0...1.5 ms. The direct control of the output A 62,00 from the user program is disabled by A 63,14 = 1.

The zero-crossing message is cancelled when the counter is set.

- Fast input of binary signals into the user program with a delay of < 0,02 ms:
  - Terminal 05 (also designated as E 62,00):  
Internal variable E 63,14
  - Terminal 06 (also designated as E 62,01):  
Internal variable E 63,15

#### Block diagram

see next page

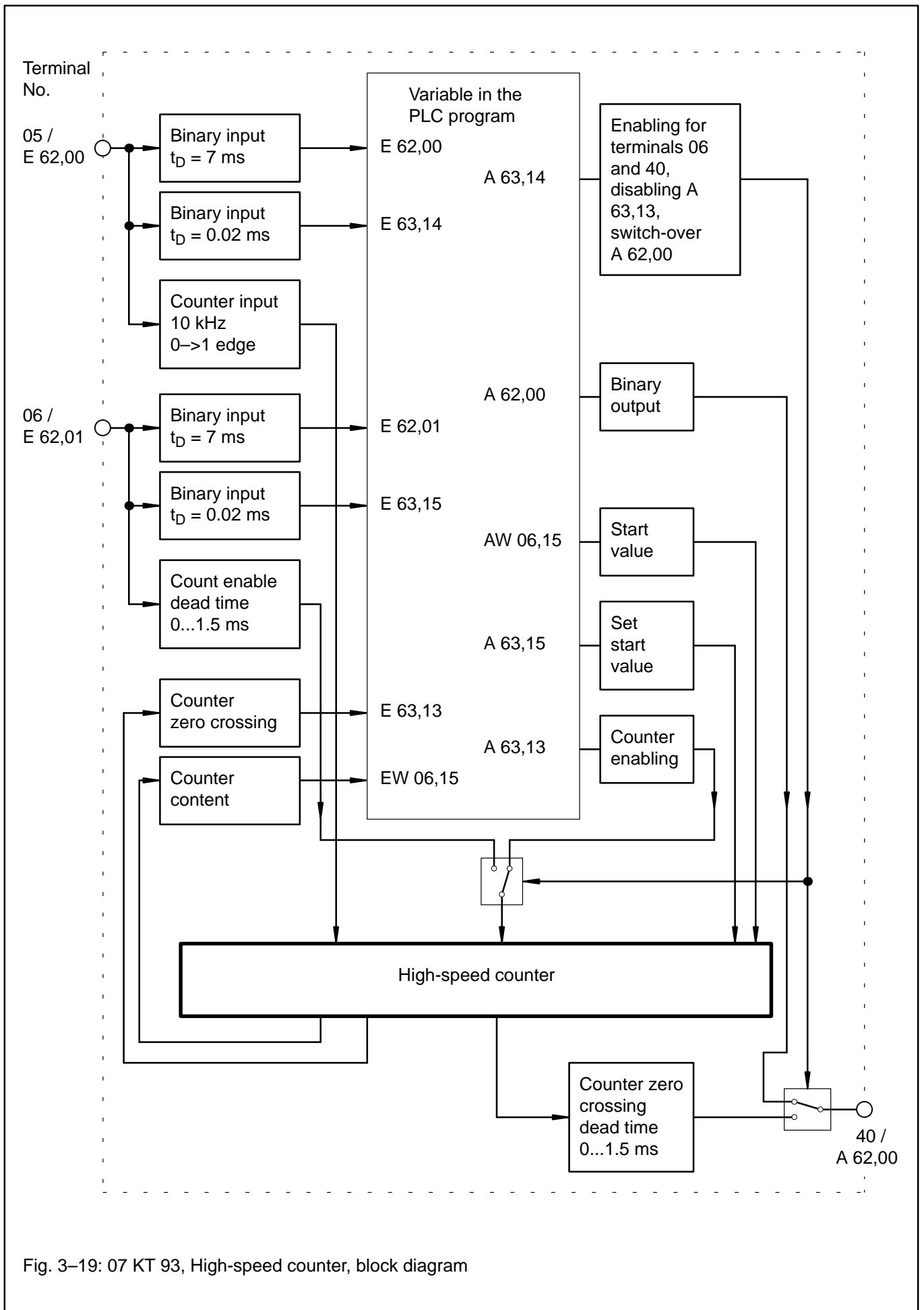

Fig. 3-19: 07 KT 93, High-speed counter, block diagram

## Configuration example

### ● Task:

- 180 pieces each of a unit load have to be filled into a packing.
- Each filled-in piece generates one pulse.
- When the packing is full, the counter is immediately prepared for the next filling operation.
- The enabling signal for the filling operation is sent by the packaging machine.
- The end of the counting operation has to be signalled to the packaging machine immediately.

### ● Wiring

- Connect the signal line for the counting pulses to terminal 05.
- Connect the signal line for the enabling of the counting operation to terminal 06.
- Connect the signal line for "zero crossing" of the counter to terminal 40.

### ● Configuration steps: PLC program

#### 1) Activate terminals 06 and 40

- The terminals 06 and 40 are activated using the operand A 63,14.

IL (instruction list):

```
! K 00,01  
= A 63,14 (with K 00,01 = 1)
```

#### 2) Preset start value for the counter

The start value (AW 06,15) is set to the value of –180. The counter will then count starting from –180 in positive direction. The transition from –1 to 0 will be signalled.

IL (instruction list):

```
! KW 01,00  
= AW 06,15 (with KW 01,00 = –180)
```

#### 3) Adopt start value into the counter

After each counting operation, the start value is immediately set again into the counter by means of the "zero crossing" signal (E 63,13). Operand A 63,15 = 1 has to be set for this purpose. At program start, the start value is loaded once into the counter by means of the initialization flag M 255,15 (M 255,15 has the value of 0 after program start).

IL (instruction list):

```
! NM 255,15  
/ E 63,13  
= A 63,15  
:  
:  
other PLC program parts  
:  
:  
! K 00,01  
= M 255,15 (set M 255,15 = 1)  
! PE (program end)
```

## Preset start values

You can preset both *positive* and *negative* start values for the counter.

The counting operation starts at the start value and is continued in correspondence with the arrows in the diagram until the enabling is stopped or a start value is loaded again.

### Negative start value

The minimum negative start value is –32768 (8000<sub>H</sub>).

By presetting a negative start value it is thus possible to count a maximum of 32768 pulses up to the zero crossing of the counter.

### Positive start value

If a positive start value is preset, the counter counts up to the value of +32767 (7FFF<sub>H</sub>), continues the counting operation at the value of –32768 (8000<sub>H</sub>) and then signals the zero crossing when reaching the transition from –1 to 0.

The minimum positive start value is 1. If you preset this value, 65535 pulses will be counted up to the zero crossing.

In order to count more than 32767 pulses up to the zero crossing, the start value has to be calculated according to the following equation:

$$\text{Start value} = 32767 - (\text{number of pulses} - 32768)$$

Example:

40 000 pulses are to be counted.

The start value is in the positive range, because more than 32768 pulses have to be counted.

Calculation:

$$\begin{aligned} \text{Start value} &= 32767 - (\text{number of pulses} - 32768) \\ &= 32767 - (40\,000 - 32768) \\ &= 25535 \end{aligned}$$

### 3.5 Technical data 07 KT 93

In general, the technical system data listed in volume 2 of the system description ABB Procontic CS31 are valid for all modules and central units. Additional data or data which are different from the system data are listed as follows.

#### 3.5.1 General data

Number of binary inputs	24
Number of binary transistor outputs	16
I/O expansion via CS31 system bus by up to	744 binary inputs 496 binary outputs 96 analog input channels 48 analog output channels max. 31 remote modules altogether
Number of serial interfaces	2 (for programming or connection to man-machine communication)
Number of parallel interfaces	1 special interface for connection of a communication processor (for networking with other bus systems)
Networking interfaces (version R171 only)	1 ARCnet interface (BNC connector)
Integrated memory, <b>07 KT 93 R101:</b>	Flash EPROM 128 kB (60 kB program + 60 kB user data) RAM 256 kB (30 kB program with online programming or 60 kB program without online programming)
Integrated memory, <b>07 KT 93 R171:</b>	Flash EPROM 128 kB (60 kB program + 60 kB user data) RAM 512 kB (60 kB program with online programming)
Resolution of the integrated real-time clock	1 second
Data of the integrated high-speed hardware counter counting range	0...65,535 (16 bits)
counting frequency	max. 10 kHz
Processing time, binary operation	typ. 0.4...0.6 ms/kB program
65 % bits, 35 % words	typ. 0.7 ms/kB program
Number of software timers delay time of the timers	any (max. 80 simultaneously active) 5 ms...24.8 days
Number of up/down counter SW blocks	any
Number of bit flags	4096
Number of word flags	4096
Number of double word flags	512
Diagnosis	cycle time monitoring, battery monitoring, detection of syntax errors and checksum monitoring
Indication of operating statuses and errors	51 LEDs altogether

### 3.5.2 Power supply

Rated supply voltage		24 V DC
Current consumption	<b>R101:</b>	max. 0.2 A plus output current through terminal 1,
	<b>R171:</b>	max. 0.25 A plus output current through terminal 1 (output voltage for the supply of the binary inputs)
Protection against reversed terminal connection		yes

### 3.5.3 24V output voltage for the supply of inputs

Rated voltage		24 V DC
Load capability	with rated voltage	max. 200 mA
	with rated voltage + 25 %	max. 240 mA
Protection against overload		with a PTC resistor
Conductor cross section of the removable 3-pole terminal block		max. 2.5 mm <sup>2</sup>

### 3.5.4 Lithium battery

Battery for back-up of RAM contents	07 LE 90 battery module
Lifetime at 25°C	1.5 years (typ. 3 years)

### 3.5.5 Binary inputs

Number of channels per module	24
Distribution of channels into groups	3 groups of 8 channels each
Common reference potential for group 1 (8 channels)	ZP1.0 (channels 62,00...62,07)
for group 2 (8 channels)	ZP1.1 (channels 62,08...62,15)
for group 3 (8 channels)	ZP1.2 (channels 63,00...63,07)
Electrical isolation	between the groups, between groups and other circuitry (see also Fig. 3–5)
Signal coupling of input signals	with optocoupler
Input signal delay of channels E 62,00...E 63,07	typ. 7 ms
channels E 63,14 and 63,15 for counter control	typ. 0.02 ms typ. 0.02 ms
Signalling of input statuses	one green LED per channel, the LEDs correspond functionally to the input signals
Input signal voltage signal 0	–30 V...+ 5 V
signal 1	+13 V...+30 V
ripple when signal 0 within –30 V...+ 5 V when signal 1	within +13 V...+30 V
Allowed input overvoltage	± 36 V, for 100 ms only
Input current per channel input voltage = +24 V	typ. 8.0 mA
input voltage = + 5 V	≥ 0.2 mA
input voltage = +13 V	≥ 2.0 mA
input voltage = +30 V	≤ 10.0 mA

Labelling for the inputs	symbol names or short signal designations can be labelled on the removeable front panel foil
Max. cable length unshielded	600 m
Max. cable length shielded	1000 m
Conductor cross section of the removable terminal blocks	max. 2.5 mm <sup>2</sup>
<b>3.5.6 Binary outputs</b>	
Number of channels per module	16 transistor outputs
Distribution of channels into groups	2 groups of 8 channels each
Common reference potential for group 1 (8 channels) for group 2 (8 channels)	ZP1.3 (channels 62,00...62,07) ZP1.4 (channels 62,08...62,15)
Common supply voltage for group 1 for group 2	UP1.3 (channels 62,00...62,07) UP1.4 (channels 62,08...62,15)
Electrical isolation	between the groups, between groups and other circuitry (see also Fig. 3–5)
Signalling of output statuses	one yellow LED per channel, the LEDs correspond functionally to the output signals
Output current rated value maximum value leakage current with signal 0	250 mA with UP1.3/UP1.4 = 24 V 312 mA with UP1.3/UP1.4 = 24 V + 25 % < 0.5 mA
Demagnetization of inductive loads	internally with free-wheeling diode and Z-diode (Z-diode voltage is 12 V)
Switching frequency with inductive loads	max. 0.5 Hz
Switching frequency with lamp load	max. 11 Hz with max. 5 W
Max. cable length	400 m (pay attention to voltage drop)
Short-circuit-proof/overload-proof reset can be carried out	yes, – automatically or – by configuration.
Total load via UP1.3 max. 2 A via UP1.4	max. 2 A
Labelling for the outputs	symbol names or short signal designations can be labelled on the removeable front panel foil
Conductor cross section of the removable terminal blocks	max. 2.5 mm <sup>2</sup>
<b>3.5.7 Connection of serial interface COM1</b>	
Interface standard	EIA RS–232
Programming with 907 PC 33	by means of IBM PC (or compatible)
Man–machine communication	yes, e.g. with ABB Procontic Operating Station 35 BS 40
Display and updating of timers, counters and parameters	yes, e.g. with TCZ Service Device

Electrical isolation		versus binary inputs and outputs, versus CS31 system bus interface (see also Fig. 3–5)
Potential differences		In order to avoid potential differences between the 07 KT 93 central unit and the peripheral device con- nected to the COM1 interface, this device is supplied from the switch cabinet socket (see also the earthing connections in Fig. 3–3).
Pin configuration and description of the COM1 interface		see chapter 3.3.10
<b>3.5.8 Connection of serial interface COM2</b>		
Interface standard		EIA RS–232
Man–machine communication		yes, e.g. with ABB Procontic Operating Station 35 BS 40
Electrical isolation		versus binary inputs and outputs, versus CS31 system bus interface (see also Fig. 3–5)
Potential differences		see text of COM1 (above)
Pin configuration and description of the COM2 interface		see chapter 3.3.11
<b>3.5.9 Connection to the ABB Procontic CS31 system bus</b>		
Interface standard		EIA RS–485
Connection	as a Master PLC as a Slave PLC	yes, transmitting and receiving area are configurable yes, see chapter "system constants"
Setting of the CS31 module address		yes, by system constant, stored in the Flash EPROM of the Slave PLC
Electrical isolation		versus supply voltage, inputs/outputs, versus COM1/COM2 interfaces (see also Fig. 3–5)
Terminal assignment and description of the CS31 bus interface		see chapter 3.3.5
Conductor cross section of the removable 3-pole terminal block		max. 2.5 mm <sup>2</sup>
<b>3.5.10 Connection to ARCnet (07 KT 93 R171 only), see also chapter A8 (Appendix)</b>		
ARCnet interface		1 channel for connection to COAX cable
Connector X4		BNC connector
Recommended system cable		COAX cable Type RG–62/U (characteristic impedance 93 Ω)
Cable length		305 m with ARCnet bus with 8 stations. Further information see SMC TECHNICAL NOTE TN7–1.
LED displays	green LED (BS)  green LED (TX)	Operating mode "controller active", i.e. the PLC performs read and write operations  Operating mode "transmit active", i.e. the PLC sends data on the ARCnet bus
Electrical isolation		versus supply voltage, inputs/outputs, versus COM1/COM2 interfaces (see also Fig. 3–5)

### 3.5.11 LED displays

LEDs for indication of:

– statuses of binary inputs	1 green LED per channel
– statuses of binary outputs	1 yellow LED per channel
– power supply exists	1 green LED
– battery	1 red LED
– program runs (RUN)	1 green LED
– error classes (FK1, FK2, FK3)	1 red LED per error class
– CS31 system bus runs (BA)	1 green LED
– bus specific errors (BE, RE, SE)	3 red LEDs
– overload/short-circuit of the direct binary outputs	1 red LED (K)

### 3.5.12 High speed hardware counter

Data of the integrated high-speed hardware counter

counting range 0...65,535 (16 bits)

counting frequency

max. 10 kHz

used inputs

62,00 and 62,01 (the signal delay of these inputs is set to 0.02 ms for the counter)

used outputs

62,00

### 3.5.13 Mechanical data

Mounting on DIN rail

according to DIN EN 50022–35, 15 mm deep.  
The DIN rail is located in the middle between the upper and the lower edges of the module.

Fastening by screws

using 4 M4 screws.

Width x height x depth

240 x 140 x 85 mm

Wiring method

by removable terminal blocks with screw-type terminals, conductor cross section max. 2.5 mm<sup>2</sup>

Weight

1.6 kg

Dimensions (for mounting)

see the following drawing

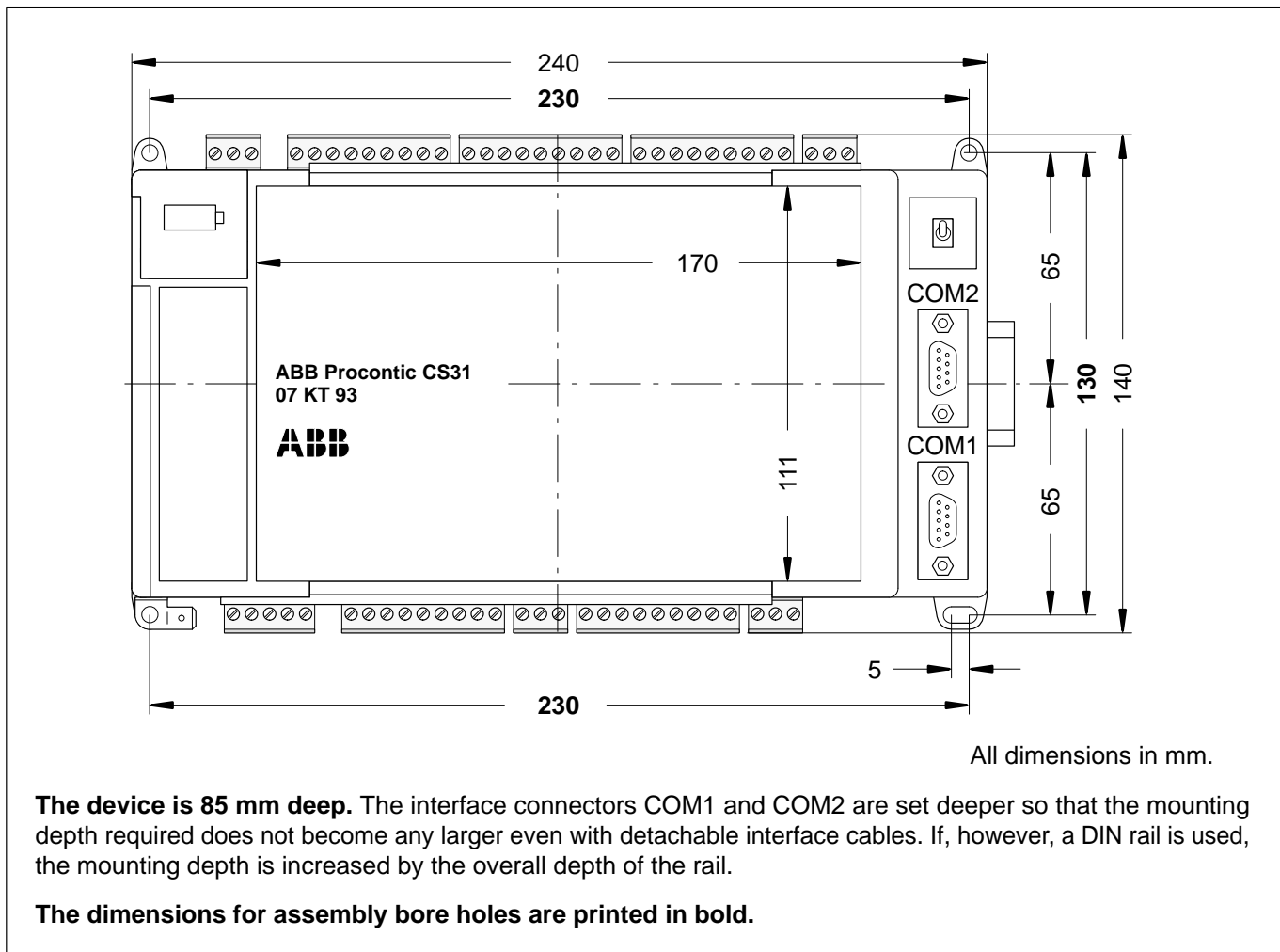

### 3.5.14 Mounting hints

Mounting position

vertical, terminals above and below

Cooling

The natural convection cooling must not hindered by cable ducts or other material mounted in the switch cabinet.

### 3.5.15 Ordering data

Central unit 07 KT 93 R101  
Central unit 07 KT 93 R171

Order No. GJR5 2513 00 R101  
Order No. GJR5 2513 00 R171

Scope of delivery

Central unit 07 KT 93 R101 or R171  
5 9-pole terminal blocks  
1 5-pole terminal block  
4 3-pole terminal blocks  
Safety and mounting instructions

#### Accessories

System cable 07 SK 90  
System cable 07 SK 91  
System cable 07 SK 92  
Battery module 07 LE 90  
Bus termination resistor

Order No. GJR5 2502 00 R1  
Order No. GJR5 2503 00 R1  
Order No. GJR5 2504 00 R1  
Order No. GJR5 2507 00 R1

Simulation device 07 SG 90  
(includes a number of switches and push-  
buttons to enter binary input signals)

Order No. GJR5 2506 00 R1

#### Programming and test software and operating manual

(both 907 PC 33 and 907 PC 331 are required)

907 PC 33 German 1)  
907 PC 33 English 1)  
907 PC 331 German 2)  
907 PC 331 English 2)

Order No. GJP5 2039 00 R202  
Order No. GJP5 2040 00 R202  
Order No. GJP5 2045 00 R202  
Order No. GJP5 2046 00 R202

#### Further Literature

System description ABB Procontic CS31	English	Order No. FPTN 440 004 R2001
System description ABB Procontic T200	English	Order No. GATS 1314 99 R2001
System description ABB Procontic T300	English	Order No. GATS 1315 99 R2002
System description ABB Procontic CS31	German	Order No. GATS 1316 99 R1002
System description ABB Procontic T200	German	Order No. GATS 1314 99 R1001
System description ABB Procontic T300	German	Order No. GATS 1315 99 R1002

1) Description General Part

2) Description 07 KR 91 / 07 KT 92 / 07 KT 93-Specific Part + Software Diskettes