

Index

General information	16.2
ILPH Range	16.4 - 16.20
ILPH RS 232 / RS 422 - 485	16.4 - 16.9
ILPH RS 232 / RS 232	16.10 - 16.11
ILPH RS 422 - 485 / RS 422 - 485	16.12 - 16.13
ILPH RS 232 / FO	16.14 - 16.17
ILPH CL / RS 422 - 485	16.18 - 16.19
ILPH RS 232 / CL	16.20
Overview	16.3

General information ILPH Range

In the field of industrial data transmission, various processes of data transmission and interfaces are used today. Thus, the user often feels the need to convert the existing interface into another interface. Simple point to point connections are most often made using the standard RS-232 (V.24), and multipoint with the RS-422 or RS-485 standard, with a current tendency to use optical fiber.

For the conversion of various interfaces, ABBENTRELEC offers connection interfaces ILPH, a large range of products for industrial use.

Uses

Adaptation :

The use of converters allows the connection of two devices using Different interfaces.

To add new equipment to existing installations.

Example :



Galvanic Isolation.

To protect sensitive equipment it is sometimes necessary to use converters which allow galvanic isolation.

Example :

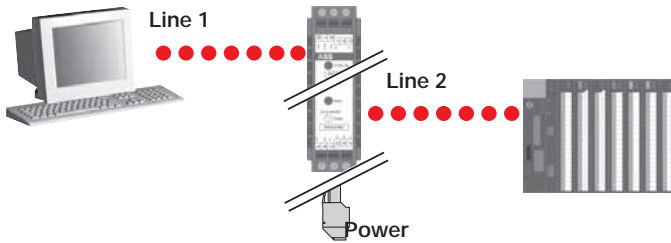

To cross a disturbed environment.

Some interfaces are more sensitive to noise. Electrically, it is preferable, in some cases, to change the interface or support.

Type of connection Immunity to noise

RS232	Low
RS422	High
RS485	High
CL	High
OF	Very high

Example :

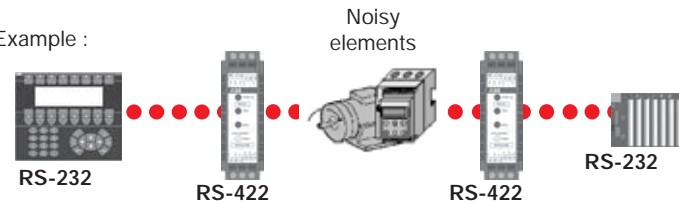

Multipoint connections

Some equipments are only designed to communicate in RS232 point to point connection. To communicate with several devices it is then necessary to use converters RS232 to RS422, RS485, BDC or FO to reach multipoint mode.

Type of connection

RS232
RS422
RS485
CL
OF

Connection

Point to point
12 points
32 points
5-6 points
32 points

Example :

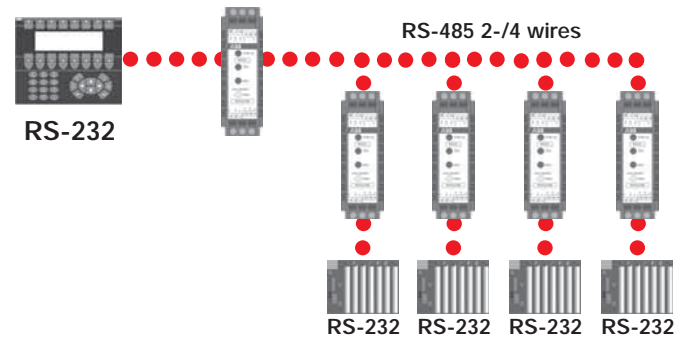

Increase in the transmission and amplification distance from the Signals.

Every connection has its own limits, to increase the communication distances you only have to change the type of link (converter) or amplify the signal (Repeater) using an ILPH.

Type of connection

RS232
RS422
RS485
CL
OF

Max. distances *

15m
1.2km
1.2km
300-500m
4km

* Depending on transmission speed.

Example :

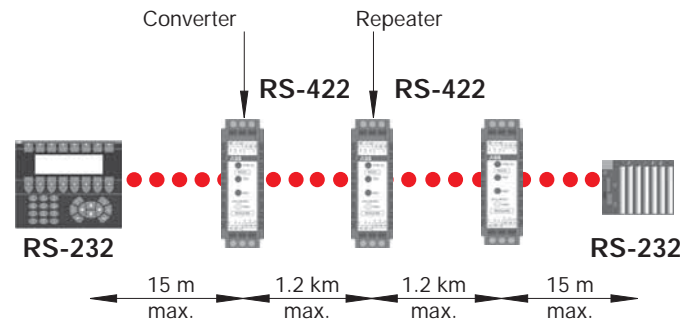

Overview ILPH Range

Serial data
converters

	RS232	RS422-485	CL	OF-S	OF-P	24 V DC	24-48 V DC	110-240 V AC	24-42 V AC/DC	Insulation *	New part numbers	Old Entelec part numbers	Old ABB part numbers
RS232	●					●				In-Ps-O	1SNA 684 234 R2000	0084 234.12	
	●						●			In-Ps-O	1SNA 684 244 R0200	0084 244.24	
		●				●				Wi	1SNA 684 231 R2500	0084 231.17	
		●				●				In-O	1SNA 684 233 R2700	0084 233.11	
		●					●			In-Ps-O	1SNA 684 333 R2300	0084 333.15	
		●						●		In-Ps-O	1SNA 684 334 R2400	0084 334.16	
			●			●				In-O	1SNA 684 202 R0100	0084 202.23	
				●				●		In-Ps-O	1SNA 684 236 R2200	0084 236.14	1SVR 084 236 R1400
				●				●		In-Ps-O	1SNA 684 237 R2300	0084 237.15	1SVR 084 237 R1500
					●			●		In-Ps-O	1SNA 684 238 R0400	0084 238.26	1SVR 084 238 R2600
					●			●		In-Ps-O	1SNA 684 239 R0500	0084 239.27	1SVR 084 239 R2700
	RS422 / RS485	●				●					In-O	1SNA 684 212 R2200	0084 212.14
		●			●					In-O	1SNA 684 232 R2600	0084 232.10	
RS485			●				●			In-Ps-O	1SNA 684 246 R0400	0084 246.26	1SVR 084 246 R2600
			●				●			In-Ps-O	1SNA 684 247 R0500	0084 247.27	1SVR 084 247 R2700
				●			●			In-Ps-O	1SNA 684 248 R1600	0084 248.00	1SVR 084 248 R0000
				●			●			In-Ps-O	1SNA 684 249 R1700	0084 249.01	1SVR 084 249 R0100

* In=Input, Ps=Power supply, O=Output, Wi=Without insulation

- **RS 232 - EIA-232 / V.24 / V.28**
Point-to-point connection
Max. 15 m transmission distance
Rate up to 19.2 kbit/s
Full-duplex

- **RS 422 - EIA-422 / V.11**
Point-to-point connection
(1 Transmitter - 10 Receivers)
Differential voltage transmission
Full-duplex
Up to 1200 m / 10Mbit/s
Good EMC characteristics

- **Current loop(TTY)**
Point-to-point / multi-point connection
Active or passive current loop
Full-duplex
Up to 1200 m/19.2 kBit/s
Good EMC characteristics

- **RS 485 - ISO/IEC/EIA-485**
Multi-point connection up to 32 units
Differential voltage transmission
Half-duplex on 1 pair
Full-duplex on 2 pairs
Up to 1200 m / 10Mbit/s
Good EMC characteristics

- **Optical fiber interface**
Point-to-point connection
Full-duplex
From 40m up to 4km transmission distance
according to optical fiber material (plastic / glass)
and wavelength used up to 10 Mbit/s
Excellent EMC characteristics

ILPH RS 232 / RS 422 - 485

RS 232 to RS 422-485 serial link without isolation

- Economic version without isolation
- Baudrate up to 38,4 kbit/s
- Transmission distance up to 1200 m
- RS 485 1 or 2 pair handling
- Usable in "noisy" environments
- 24 V DC power supply
- CE mark

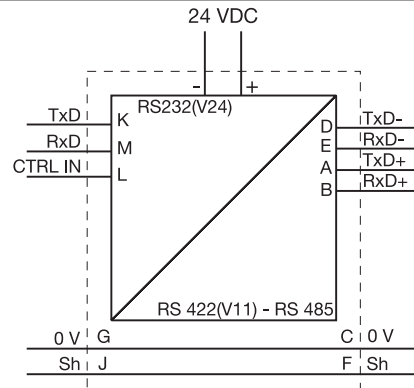
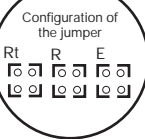
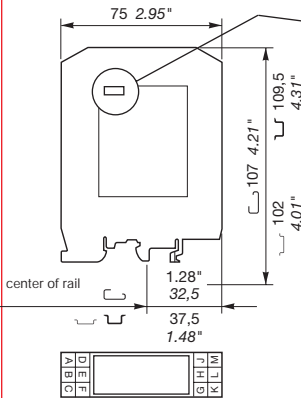
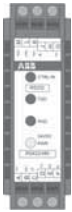

Description	Type	Catalog number	Packaging	Weight kg
Serial link interface without galvanic isolation	ILPH RS 232 / RS 422-485	1SNA684231R2500	1	0.1

RS 485 LINK ON ONE PAIR

R	E	R ON/OFF	Jumper R in position	R ON/OFF
		R ON/OFF	Jumper R in position	R ON/OFF
		E ON/OFF	Jumper E in position	E ON/OFF

The Receiver and the Transmitter are activated alternately (never at the same time) depending on the status of the CTRL IN signal.

CTRL IN STATUS	ACTION ON RS 485
0 logic (+3V ≤ U ≤ +25V)	Transmitter active / Receiver inactive
1 logic (-25V ≤ U ≤ -3V)	Transmitter inactive / Receiver active
High impedance	Transmitter inactive / Receiver active

NOTE : For RS 232 products running the RTS (REQUEST TO SEND) signal, connect RTS to CTRL IN. Otherwise, connect M (RxD ILPH) to L (CTRL IN).

RS 485 LINK ON 2 PAIRS

R	E	R ON/OFF	Jumper R in position	R ON/OFF
		R ON	Jumper R in position	R ON
		E ON/OFF	Jumper E in position	E ON/OFF

Receiver permanently active
Transmitter controlled by the signal CTRL IN (see table for Transmitter operation as a function of CTRL IN)

RS 422 LINK ON TWO PAIRS

R	E	R ON/OFF	Jumper R in position	R ON/OFF
		R ON	Jumper R in position	R ON
		E ON	Jumper E in position	E ON

The Transmitter and Receiver are both permanently active.

POLARIZATION OF THE RS 422 - RS 485 LINE

The line must always be polarized. The ILPH is used to polarize the reception channel :
Connection by 1 wire P+ (J1.1) with 5V (J1.4)
Connection by 1 wire P- (J1.2) with 0V (J1.3)

ADAPTING THE RS 422 - RS 485 LINE

The line must always be adapted to the level of the reception channel of each subscriber forming the end of the bus. The ILPH is used to adapt the reception channel by setting the jumper Rt correctly :

Rt	* Line adaptation, Rt = 120 Ω (general case)
Rt	* Line adaptation, Rt = 220 Ω
Rt	* No line adaptation, Rt = ∞

RS 422 - RS 485 SERIAL LINK (2 wires)

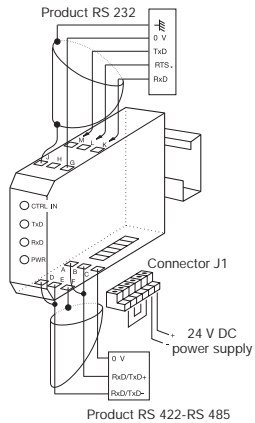

***CAUTION :**
When the RTS Signal is not activated, M terminal (RxD ILPH) has to be connected to L terminal (CTRL IN).

RS 422 - RS 485 SERIAL LINK (4 wires)

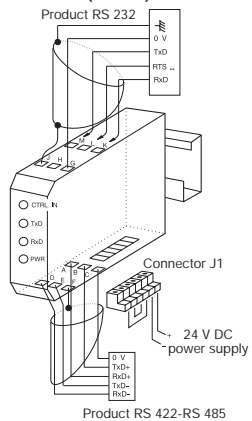

**** CAUTION :**
To be connected to 2 wired RS 485 only (not possible for 4 wired RS 422).
When the RTS Signal is not activated, M terminal (RxD ILPH) has to be connected to L terminal (CTRL IN).

Technical data

Power supply	polarized
Voltage	24 V DC
Voltage tolerance	8,5...28 V DC
Supply current	100 mA max
Connections	removable screw connectors (AWG 20)
RS 232-1 serial link	EIA RS 232 C / CCITT V24 V28
Overvoltage protection	integrated (transil 8 kV 1,2/50 µs)
Baud rate / Transmission distance	max. 38,4 kbits/s / max. 1200 m
Connections	2,5 mm ² screw connectors (AWG 20)
RS 422-485-2 serial link	EIA RS 485 and EIA RS 422 / CCITT V11
Overvoltage protection	integrated (transil 8 kV 1,2/50 µs)
Baud rate / Transmission distance	max. 38,4 kbits / max. 1200 m
Connections	2,5 mm ² screw connectors (AWG 20)
Traffic indication	
Voltage	1 yellow LED
Status of signal	2 green LED (RxD, TxD)
EMC behavior	
Electrostatic discharge	EN 61000-4-2 level 3 6/8 kV
Radiated electromagnetic field	EN 61000-4-3 level 310 V/m
Burst	EN 61000-4-4 level 3 1 kV
Electromagnetic compatibility	EN 55022 class B
Other characteristics	
Galvanic isolation between input / power supply / output	no
Configuration of the operating mode	using internal jumper
Operating temperature	0°C ... +50°C
Storage temperature	-25°C ... +80°C
Mounting	any required
DIN rail fixing (EN 50002)	snap-on mounting
Wire size	2,5 mm ² / stranded with ferrule, 4 mm ² solid
Dimensions (LxBxH)	88 x 22,5 x 102 mm
Weight	100 g

ILPH RS 232 / RS 422 - 485



- Galvanic isolated converter for RS 232 to RS 422-485 serial links.
- Galvanic isolation between input/output and output/power supply
- Baudrate up to 38,4 kbit/s
- Transmission distance up to 1200 m
- RS 485 1 or 2 pair handling
- Usable in "noisy" environments
- 24 V DC power supply
- CE mark

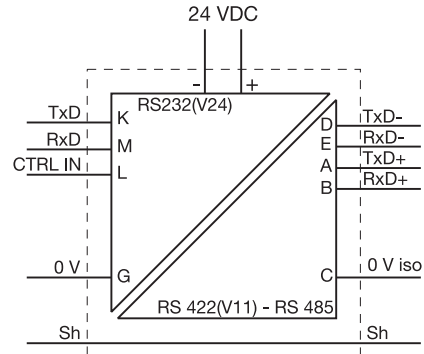
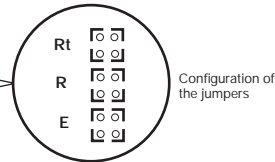
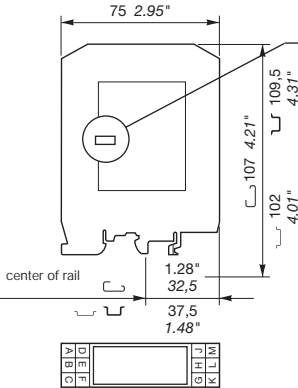

Description	Type	Catalog number	Packaging	Weight kg
Serial link interface without galvanic isolation	ILPH RS 232 / RS 422-485	1SNA684233R2700	1	0.1

RS 485 LINK ON ONE PAIR

- R R ON/OFF Jumper R in position R ON/OFF
- E E ON/OFF Jumper E in position E ON/OFF

The Receiver and the Transmitter are activated alternately (never at the same time) depending on the status of the CTRL IN signal.

CTRL IN STATUS	ACTION ON RS 485
0 logic (+3V ≤ U ≤ +25V)	Transmitter active / Receiver inactive
1 logic (-25V ≤ U ≤ -3V)	Transmitter inactive / Receiver active
High impedance	Transmitter inactive / Receiver active

CAUTION : For RS 232 products running the RTS (REQUEST TO SEND) signal, connect RTS to CTRL IN. Otherwise, connect M (RxD ILPH) to L (CTRL IN).

RS 485 LINK ON 2 PAIRS

- R R ON Jumper R in position R ON
- E E ON/OFF Jumper E in position E ON/OFF

Receiver permanently active
Transmitter controlled by the signal CTRL IN (see table for Transmitter operation as a function of CTRL IN)

RS 422 LINK ON TWO PAIRS

- R R ON Jumper R in position R ON
- E E ON Jumper E in position E ON

The Transmitter and Receiver are both permanently active.

POLARIZATION OF THE RS 422 - RS 485 LINE
The line must always be polarized. The ILPH is used to polarize the reception channel :
Connection by 1 wire P+ (J1.1) with 5V (J1.4)
Connection by 1 wire P- (J1.2) with 0V (J1.3)

ADAPTING THE RS 422 - RS 485 LINE
The line must always be adapted to the level of the reception channel of each subscriber forming the end of the bus. The ILPH is used to adapt the reception channel by setting the jumper Rt correctly :

- Rt * Line adaptation, Rt = 120 Ω (general case)
- Rt * Line adaptation, Rt = 220 Ω
- Rt * No line adaptation, Rt = ∞

RS 422 - RS 485 2 WIRE SERIAL LINKS

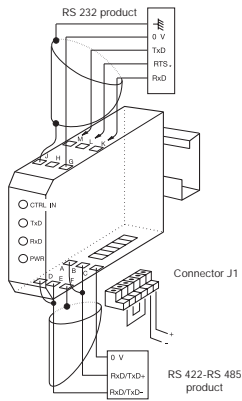

*** CAUTION :**
If the RTS signal is not generated, connect M (RxD ILPH) to L (CTRL IN).

RS 422 - RS 485 4 WIRE SERIAL LINKS

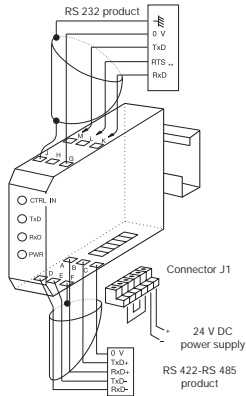

**** CAUTION :**
Only to be connected for RS 485 two pairs (of no use for RS 422 two pairs). If the RTS signal is not generated, connect M (RxD ILPH) to L (CTRL IN).

Technical data

Power supply

Voltage	polarized 24 V DC
Voltage tolerance	8,5...28 V DC
Supply current	100 mA max
Connections	Removable screw connectors (Omniconnect)

RS 232-1 serial link

Overvoltage protection	EIA RS 232 C / CCITT V24 V28 integrated (transil 8 kV 1,2/50µs)
Baud rate / Transmission distance	max. 38,4 kbits/s / max. 15 m
Connections	2,5 mm ² screw connectors (AWG 20)

RS 422-RS485-2 serial link

Overvoltage protection	EIA RS 485 and EIA RS 422 / CCITT V11 integrated (transil 8 kV 1,2/50 µs)
Baud rate / Transmission distance	max. 38,4 kbits / max. 1200 m
Connections	2,5 mm ² screw connectors (AWG 20)

Traffic indication

Voltage	1 yellow LED
Status of signal	3 green LED (RxD, TxD and CTRL-IN)

EMC behavior

Electrostatic discharge	EN 61000-4-2 level 3 6/8 kV
Radiated electromagnetic field	EN 61000-4-3 level 310 V/m
Burst	EN 61000-4-4 level 3 1 kV
Electromagnetic compatibility	EN 55022 class B

Other characteristics

Galvanic isolation between RS 232/RS 422-485 and RS 422-485/power supply	500 V DC
Configuration of the operating mode	using internal jumper
Operating temperature	0°C ... +50°C
Storage temperature	-25°C ... +80°C
Mounting	any required
DIN rail fixing (EN 50002)	snap-on mounting
Wire size	2,5 mm ² / stranded with ferrule, 4 mm ² solid
Dimensions (LxBxH)	88 x 22,5 x 102 mm
Weight	100 g

ILPH RS 232 / RS 422 - 485



- 3 way galvanic isolated converter for RS 232 to RS 422-485 serial links.
- 3 way galvanic isolation between power supply and input/output
- RS 485 switch on 2 or 4 wires
- Baudrate up to 38,4 kbit/s
- Transmission distance up to 1200 m
- RS 485 1 or 2 pair handling
- Usable in "noisy" environments
- 24...48 V DC and 115...230 V AC power supply
- CE marking

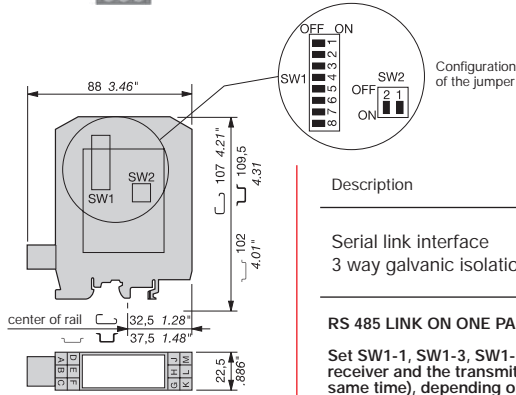
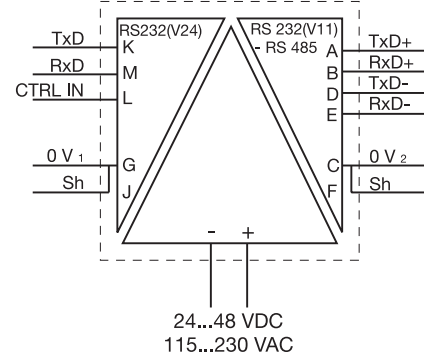

Description	Type	Catalog number	Packaging	Weight kg
Serial link interface	ILPH RS 232 / RS 422-485	1SNA684333R2300	1	0.1
3 way galvanic isolation	24 - 48 VDC power supply	1SNA684333R2300	1	0.1
	115 - 230 VAC power supply	1SNA684334R2400	1	0.1

RS 485 LINK ON ONE PAIR

Set SW1-1, SW1-3, SW1-6, SW1-7 and SW1-8 to position ON. The receiver and the transmitter are activated alternately (never at the same time), depending on the status of the CTRL IN signal.

CTRL IN STATUS	Action on RS 485
0 Logic ($3V \leq U \leq +25V$)	Transmitter active / Receiver inactive
1 Logic ($-25V \leq U \leq -3V$)	Transmitter inactive / Receiver active
High impedance	Transmitter inactive / Receiver active

CAUTION : For RS 232 products running the RTS signal (REQUEST TO SEND), connect RTS to CTRL IN. Otherwise, set SW2-1 to position ON.

RS 485 LINK ON TWO PAIRS

Set SW1-1, SW1-3, SW1-7 in position OFF. Set SW1-6, SW1-8 in position ON. The receiver is permanently active. The transmitter is controlled by the signal CTRL IN (see table for transmitter operation as a function of CTRL IN).

RS 422 LINK ON TWO PAIRS

Set SW1-1, SW1-3, SW1-7 and SW1-8 in position OFF. Set SW1-6 in position ON. Transmitter and receiver are both permanently active.

POLARIZATION OF THE RS 422 - RS 485 LINE

The line must always be polarized. The ILPH is used to polarize the reception channel : Set SW1-4 and SW1-5 in position ON.

ADAPTING THE RS 422 - RS 485 LINE

The line must always be adapted to the level of the reception channel of each subscriber forming the end of the bus.

The ILPH is used to adapt the reception channel by setting the jumper SW1-2 correctly :

- SW1-2 in position ON \Rightarrow line adaptation, $R_t = 120 \Omega$ (standard)
- SW1-2 in position OFF \Rightarrow no line adaptation, $R_t = \infty$

RS 422 - RS 485 2 WIRE SERIAL LINK

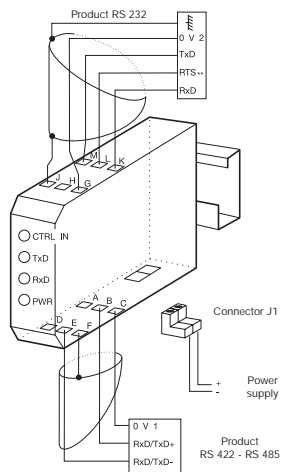

***CAUTION :**
When the RTS signal is not generated, set SW2-1 in position ON.

RS 422 - RS 485 4 WIRE SERIAL LINKS

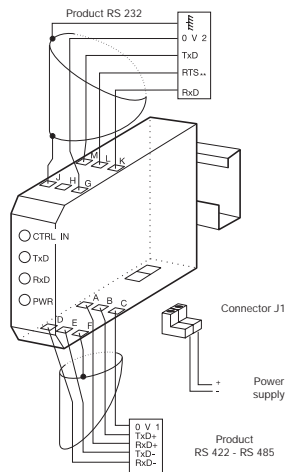

****CAUTION :**
Only to be connected for RS 485 two pairs (of no use for RS 422 two pairs).
If the RTS signal is not generated, set SW2-1 in position ON.

Technical data

Power supply

Voltage	24...48 V DC	115...230 V AC (50/60 Hz)
Voltage tolerance	-15% ... +20%	-15% ... +15%
Supply current	24 V DC < 110 mA, 48 V DC < 55 mA, 115 V AC < 40 mA, 230 V DC < 26 mA	
Supply power	≈ 3 W	≈ 3 VA
Connections	Removable screw connector (Omniconnect)	

RS 232-1 serial link

Overvoltage protection	EA / TIA RS 232 new revision / CCITT V24 V28 integrated (transil 8 kV 1,2/50 μs)
Baud rate / Transmission distance	max. 38,4 kbits/s / max. 15 m / 2500 pF
Connections	2,5 mm ² screw (AWG 20)

RS 422/485-2 serial link

Overvoltage protection	EIA RS 485 and EIA RS 422 CCITT V11 integrated (transil 8 kV 1,2/50 μs)
Baud rate / Transmission distance	max. 38,4 kbits / max. 1200 m
Connections	2,5 mm ² screw (AWG 20)

Traffic indication

Voltage	1 yellow LED
Status of signal	3 green LED (Rx/D, Tx/D and CTRL-IN)

EMC behavior

Electrostatic discharge	EN 61000-4-2 level 3 6/8 kV
Radiated electromagnetic field	EN 61000-4-3 level 310 V/m
Burst	EN 61000-4-4 level 3 1 kV
Electromagnetic compatibility	EN 55022 class B

Other characteristics

Galvanic isolation between RS 232 / Power supply / RS 422-RS 485	1,5 kV
Configuration of the operating mode	using internal jumper
Operating temperature	0°C ... +50°C
Storage temperature	-25°C ... +80°C
Mounting	any required
DIN rail fixing (EN 50002)	snap-on mounting
Wire size	2,5 mm ² / stranded with ferrule, 4 mm ² solid
Dimensions (LxBxH)	88 x 22,5 x 102 mm
Weight	100 g

ILPH RS 232 / RS 232

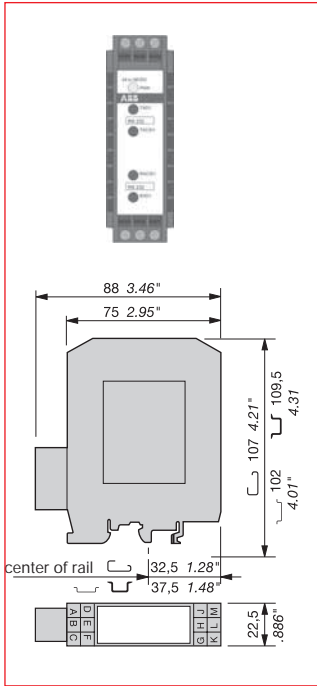

3 way galvanic isolator between RS 232 serial interface and another RS 232 serial interface.

- Ensures triple insulation between the 2 serial interfaces and between each and power supply
- Baudrate up to 19,2 kbit/s (up to 64 kbit/s depending on cable)
- Transmission distance up to 15 m
- Can be used in "noisy" environments
- Power supply from 24...48 V DC and 115...230 V AC
- CE marking

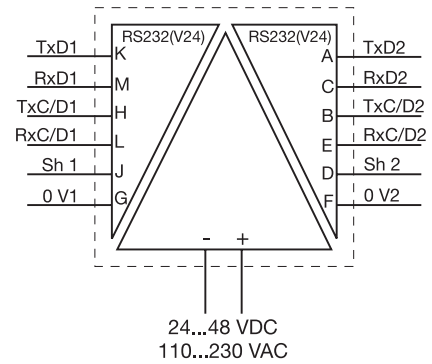

Description	Type	Catalog number	Packaging	Weight kg
Serial link interface	ILPH RS 232 / RS 232			
3 way galvanic isolation	24 - 48 VDC power supply	1SNA684234R2000	1	0.1
	115 - 230 VAC power supply	1SNA684244R0200	1	0.1

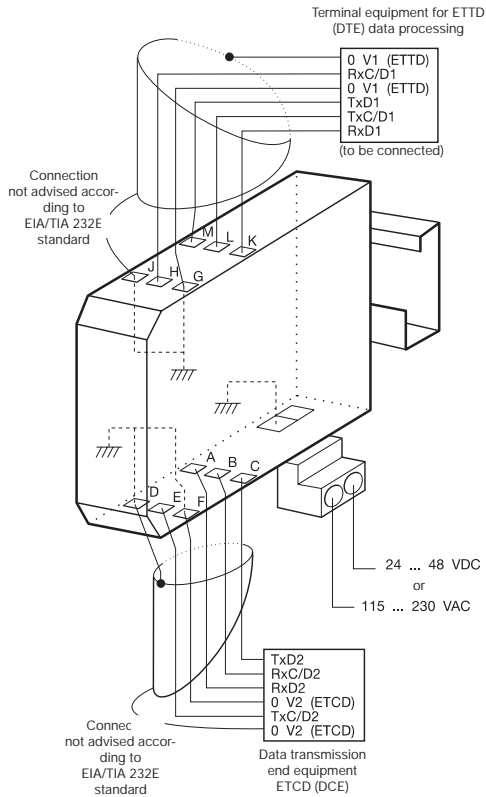

Technical data

Power supply

Voltage	24...48 V DC	115...230 V AC (50/60Hz)
Voltage tolerance	-15%...+20%	-15%...+15%
Supply current	24 V DC<155 mA;48 V DC<77 mA;110 V AC<40 mA;230 V DC<26 mA	
Supply power	≈ 3,15 W	≈ 3,15 VA
Connections	Removable screw connector (Omniconnect)	

RS 232-1 interface

Overvoltage protection	EIA / TIA RS 232 new revision / CCITT V24 V28 integrated (transil 8 kV 1,2/50 μs)
Transmission capacity / Transmission distance	max. 19,2 kbits/s / max. 15 m / 2500 pF
Connections	2,5 mm ² screw (AWG 20)

RS 232-2 interface

Overvoltage protection	EIA / TIA RS 232 new revision / CCITT V24 V28 integrated (transil 8 kV 1,2/50 μs)
Transmission capacity / Transmission distance	max. 19,2 kbits/s / max. 15 m
Connections	2,5 mm ² screw (AWG 20)

Traffic indication

Voltage	1 yellow LED
Status of signal	4 green LED (RxD, RxC/D, TxD, TxC/D)

EMC behavior

Electrostatic discharge	EN 61000-4-2 level 3 6/8 kV
Radiated electromagnetic field	EN 61000-4-3 level 3 10 V/m
Burst	EN 61000-4-4 level 3 1 kV
Electromagnetic compatibility	EN 55022 class B

Other characteristics

Galvanic isolation between input / power supply / output	1,5 kV
Configuration of the operating mode	No
Operating temperature	0°C ... +50°C
Storage temperature	-25°C ... +80°C
Mounting	any required
DIN rail fixing (EN 50002)	snap-on mounting
Wire size	2,5 mm ² / stranded with ferrule, 4 mm ² solid
Dimensions (LxBxH)	88 x 22,5 x 102 mm
Weight	100 g

ILPH RS 422 - 485 / RS 422 - 485



Galvanic isolated connection between an RS 422-485 (1 or 2 pairs) and an RS 422 485 (1 or 2 pairs) serial link. It amplifies the signal beyond the 1200 m limit distance of the RS 422-485 and only needs a minimum of 1,5 character delay time to switch off the RS 485 drivers.

- Galvanic isolation between power supply/output and input/output
- Baudrate up to 500 kbit/s (up to 200 m)
- Transmission distance up to 1200m at 38,4 kbit/s
- Usable in "noisy" environments
- 2/4 wires automatic handling
- 24 V DC power supply
- CE mark

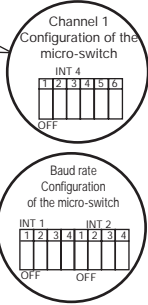

	INT 1	INT 2	INT 3	INT 4
BAUD RATE	1 2 3 4	1 2 3 4	1 2 3 4	1 2 3 4 5 6
FULL DUPLEX	0 0 0 0	0 0 0 0	X X X 1	X X X 1 0 1
500 Kb/s	1 1 1 1	1 1 1 1	X X X 0	X X X 0 0 0
187,5 Kb/s	1 1 1 1	1 1 1 0	X X X 0	X X X 0 0 0
93,75 Kb/s	1 1 1 1	1 1 0 0	X X X 0	X X X 0 0 0
38,4 Kb/s	1 1 1 1	1 0 0 0	X X X 0	X X X 0 0 0
19,2 Kb/s	1 1 1 1	0 0 0 0	X X X 0	X X X 0 0 0
9,6 Kb/s	1 1 1 0	0 0 0 0	X X X 0	X X X 0 0 0
4,8 Kb/s	1 1 0 0	0 0 0 0	X X X 0	X X X 0 0 0
2,4 Kb/s	1 0 0 0	0 0 0 0	X X X 0	X X X 0 0 0
1,2 Kb/s	0 0 0 0	0 0 0 0	X X X 0	X X X 0 0 0

Nu = not used 1 = contact closed
 X = zero 0 = contact open (aus) (off)

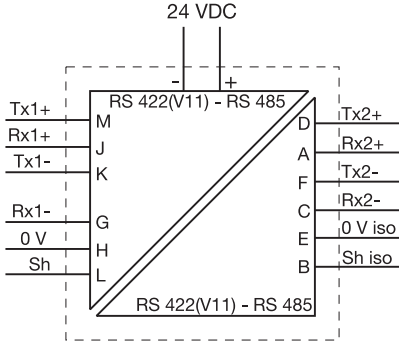

Description	Type	Catalog number	Packaging	Weight kg
Serial link interface with galvanic isolation	ILPH RS 422 - 485 / RS 422 - 485 24 - 48 VDC power supply	1SNA684212R2200	1	0.1

RS 422 - RS 485 DRIVERS CONTROL

The RS 422 - RS 485 Drivers Control (transmitters and receivers) makes the ILPH easy to use. The control of the 2 channels is completely automatic ; you only have to configure the baud rate needed.

The minimum turn off delay is about 1,5 character/time from 27 µs to 10 ms depending on the baud rate selected.

POLARIZATION OF THE RS 422 - RS 485 CONNECTIONS

The connections must always be polarized. The ILPH is used to polarize the reception channels :

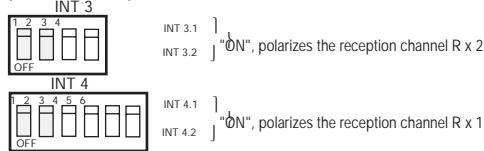

ADAPTING THE RS 422 - RS 485 CONNECTIONS

The connections must always be adjusted to the level of the reception channel of each subscriber forming the end of the bus. The ILPH is used to adjust the reception channel by setting the micro-switch INT 3.3 and INT 4.3.



BAUD RATE

By using the 8 micro-switches inside the box.

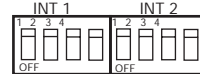

Permits to define up to 8 transmission speeds and to select the Full Duplex operation mode (RS 422 / RS 422) in addition with the INT 3.4 INT 4.4 and INT 4.5 micro switches.

RS 422 - RS 485 2 wire serial link

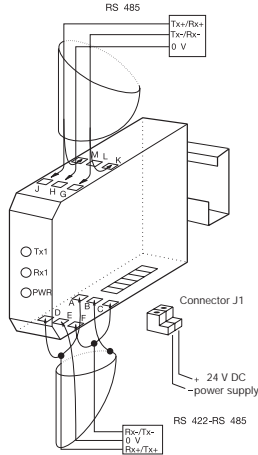

RS 422 - RS 485 4 wire serial link

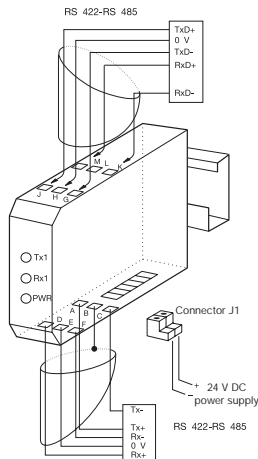

Caution :
The transmission channels of both RS 422 - RS 485 serial link interfaces always have to be independently polarized.

Technical data

Power supply Voltage Voltage tolerance Supply current Connections	DC model polarized 24 V DC +/-15% 120 mA max. Removable screw connector (Omniconnect)
RS 422-485-1 interface Overvoltage protection RS 485 data switching Baudrate / Transmission distance Connections	EIA / RS 432 and EIA RS 422 / CCITT V11 integrated (transil 8 kV 1,2/50 µs) Time switching / Time delay transmission/reception 27 µs ... 10 ms from 1,2 to 500 kbits/s / max. 1200 m up to 38,4 kbit/s 2,5 mm ² screw (AWG 20)
RS 422-485-2 interface Overvoltage protection RS 485 data switching Baudrate / Transmission distance Connections	EIA / RS 485 and EIA RS 422 / CCITT V11 integrated (transil 8 kV 1,2/50 µs) Time switching / Time delay transmission/reception 27 µs ... 10 ms from 1,2 to 500 kbits/s / max. 1200 m up to 38,4 kbit/s 2,5 mm ² screw (AWG 20)
Traffic indication Voltage Status of signal	1 yellow LED 2 green LED (RxD, TxD,)
EMC behavior Electrostatic discharge Radiated electromagnetic field Burst Electromagnetic compatibility	EN 61000-4-2 level 3 6/8 kV EN 61000-4-3 level 3 10 V/m EN 61000-4-4 level 3 1 kV EN 55022 class B
Other characteristics Galvanic isolation between input / power supply / output Configuration of the operating mode Operating temperature Storage temperature Mounting DIN rail fixing (EN 50002) Wire size Dimensions (LxBxH) Weight	500 V DC using internal DIP switches 0°C ... +50°C -25°C ... +80°C any required snap-on mounting 2,5 mm ² / stranded with ferrule, 4 mm ² solid 88 x 22,5 x 102 mm 100 g

ILPH RS 232 / FO

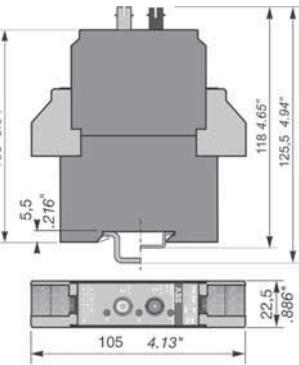
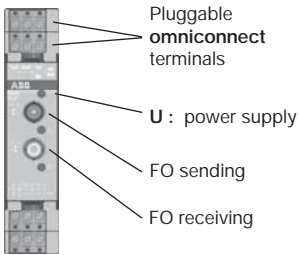

3 way galvanic isolated Converter for RS 232 to optical fiber serial link glass (S) or plastic (P).

- 3 way galvanic isolation between power supply and input/output
- Baud rate up to 115,2 kbit/s
- Available for glass or plastic fiber
- Transmission distance up to 4 km
- Usable in "very noisy" environments
- 20...42 V AC/DC and 110...240 V AC/DC power supply
- CE marked

■ Approvals :  in process

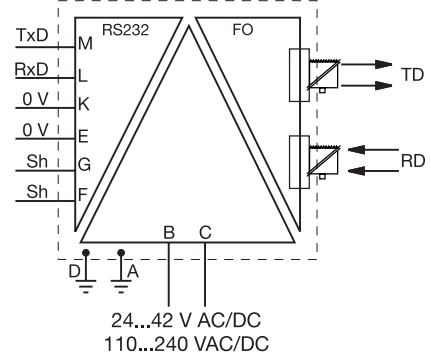

Description	Type	Catalog number	Packaging	Weight kg
Serial link interface 3 way galvanic isolation	ILPH RS 232 / FO-S 24 - 42 VAC/DC power supply	1SNA684236R2200	1	0.15
	110 - 240 VAC/DC power supply	1SNA684237R2300	1	0.15
Serial link interface 3 way galvanic isolation	ILPH RS 232 / FO-P 24 - 42 VAC/DC power supply	1SNA684238R0400	1	0.15
	110 - 240 VAC/DC power supply	1SNA684239R0500	1	0.15

RS 232 / FO

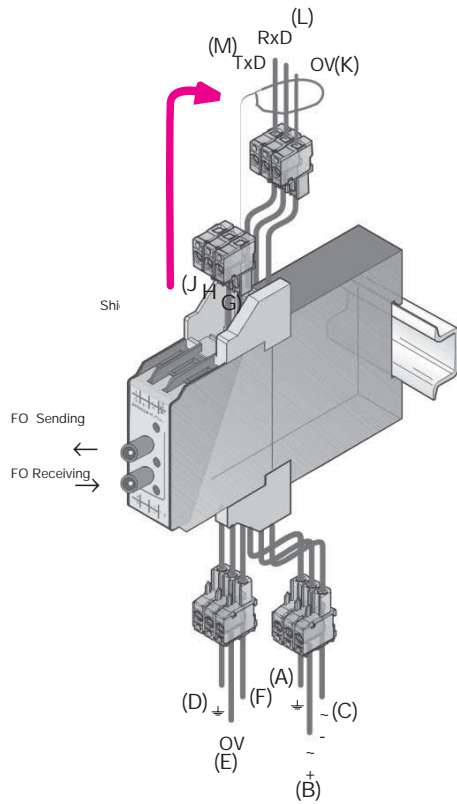

Technical data

Power supplies

Supply voltage (50/60 Hz)	24...42 V AC/DC (50/60 Hz)	110...240 V AC/DC
Voltage tolerance	-15% ... +10%	-15% ... +10%

Connections

RS 232 Interface 1

Protection	Omniconnect pluggable connector
Max. speed / Max. distance	CCITT V.24/DIN 66020- CCITT V.28 DIN 66259-EIA 232 E Integrated (transil 8 kV 1.2/50µs)
Connections	Max. 115.2 kbits/s / max. 15 m / 2500 pF Omniconnect pluggable connector

Fiber optic interface 2

Type of fiber / Connections	DIN VDE 0888-1 Multimode fiber Glass : ST connector Plastic : FSMA screw connector
Wavelength	Glass : 820 nm Plastic : 655 nm
Max. transmission power	Glass : 50/125 µm : -14.4 db/m Glass : 62.5/125 µm : -14 db/m Plastic : 980/1000 µm : -8 db/m
Max. reception power	Glass : -28 db/m Plastic : -20 db/m
Max. speed	Max. 115.2 kbits/s
Max. distance	Glass : 50/125 µm : 3 km Glass : 62.5/125 µm : 4 km Plastic : 980/1000 µm : 40 m

Status indication

Power supply / Data exchange	1 green LED / 2 green LEDs (RxD, TxD)
------------------------------	---------------------------------------

EMC behavior

Electrostatic discharge	EN 61000-4-2 Level 3 6/8 kV
Radiated electromagnetic field	EN 61000-4-3 Level 3 10 V/m
Burst	EN 61000-4-4 Level 3 1 kV
Electromagnetic compatibility	EN 55022 Class B

Other characteristics

Galvanic isolation input / power supply / output	2.5 kV
Operating temperature	-20°C ... +60°C
Storage temperature	-40°C ... +85°C
Mounting	Onto DIN Rail (EN 50002)
Connections	14 AWG (2.5 mm ²) fine stranded / 12 AWG (4 mm ²) rigid
Dimensions (LxWxH)	105 x 22.5 x 112 mm / 4.13 x 0.89 x 4.41"
Weight	150 g / 0.33 lb

ILPH RS 485 / FO

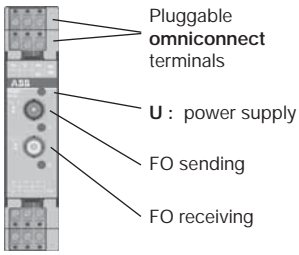

- 3 way galvanic isolated converter for RS 485 (1 pair) to optical fiber serial link glass (S) or plastic (P).
- 3 way galvanic isolation between power supply and input/output
- Baud rate up to 1.5 Mbit/s
- Available for glass fiber or plastic fiber
- Transmission distance up to 4 km
- Usable in "very noisy" environments
- 20...42 V AC/DC and 110...240 V AC/DC power supply
- CE marked
- Approvals: in process

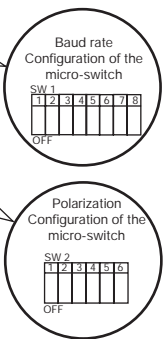
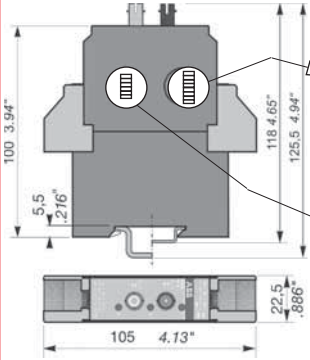

Baud rate :
SW1 DIP switch configuration

Baudrate bit/s	SW 1							
	1	2	3	4	5	6	7	8
1500000	■	■	■	■	■	■	■	■
500000	■	■	■	■	■	■	■	■
375000	■	■	■	■	■	■	■	■
187500	■	■	■	■	■	■	■	■
138000	■	■	■	■	■	■	■	■
115200	■	■	■	■	■	■	■	■
93750	■	■	■	■	■	■	■	■
75000	■	■	■	■	■	■	■	■
57600	■	■	■	■	■	■	■	■
38400	■	■	■	■	■	■	■	■
19200	■	■	■	■	■	■	■	■
9600	■	■	■	■	■	■	■	■
4800	■	■	■	■	■	■	■	■
300	■	■	■	■	■	■	■	■

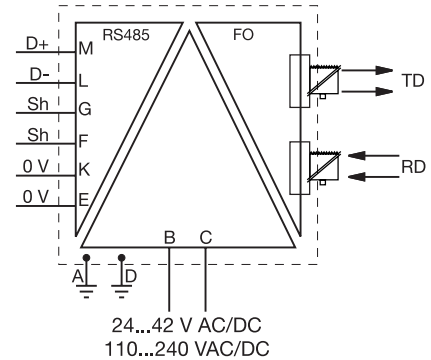

End-of-line resistor, polarization
SW2 DIP switch configuration

Polarization	SW 2					
	1	2	3	4	5	6
EOL 60 ohm	■	■	■	■	■	■
EOL 120 ohm	■	■	■	■	■	■
EOL 180 ohm	■	■	■	■	■	■
EOL 240 ohm	■	■	■	■	■	■
EOL indefinite	■	■	■	■	■	■

Description	Type	Catalog number	Packaging	Weight kg
Serial link interface 3 way galvanic isolation	ILPH RS 485 / FO-S 24 - 42 VAC/DC power supply	1SNA684246R0400	1	0.15
	110 - 240 VAC/DC power supply	1SNA684247R0500	1	0.15
Serial link interface 3 way galvanic isolation	ILPH RS 485 / FO-P 24 - 42 VAC/DC power supply	1SNA684248R1600	1	0.15
	110 - 240 VAC/DC power supply	1SNA684249R1700	1	0.15

RS 485 / FO

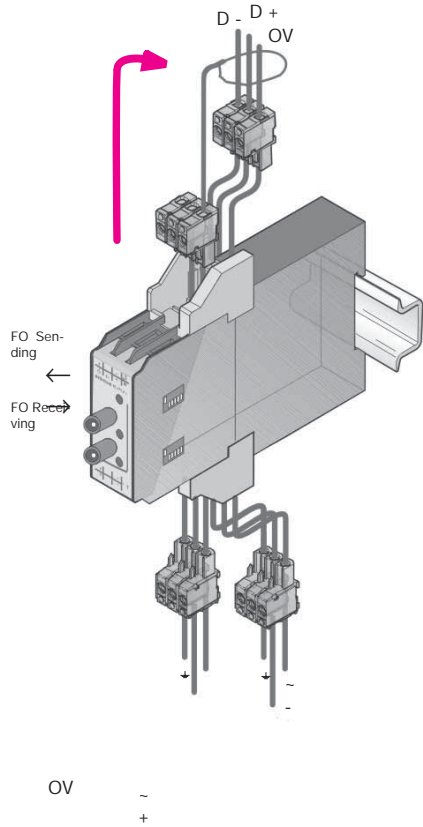

Technical data

Power supplies	
Supply voltage	24...42 V AC/DC (50/60 Hz) 110...240 V AC/DC (50/60 Hz)
Voltage tolerance	-15% ... +10% -15% ... +10%
Connections	Omniconnect pluggable connector
RS 485 interface 1	
Protection	ISO / IEC 8482 / DIN 66 259-4; EIA 485
Max. speed / max. distance	Integrated (8 kV 1.2/50µs) Max. 1.5 Mbits/s / max. 1200 m (38.4 kbit/s)
Connections	Omniconnect Pluggable connector
Optic fiber interface 2	
Type of fiber / Connections	DIN VDE 0888-1 Multimode fiber Glass : ST connector Plastic : FSMA screw connector
Wavelength	Glass : 820 nm Plastic : 655 nm
Max. transmission power	Glass : 50/125 µm : -14.4 db/m Glass : 62.5/125 µm : -14 db/m Plastic 980/1000 µm : -8 db/m
Max. reception power	Glass : -28 db/m Plastic : -20 db/m
Max. speed	Max. 1.5 Mbit/s
Max. distance	Glass : 50/125 µm : 3 km Glass : 62.5/125 µm : 4 km Plastic 980/1000 µm : 40 m
Status indication	
Power supply / Data exchange	1 green LED / 2 green LEDs (Rx/D, Tx/D)
EMC behavior	
Electrostatic discharge	EN 61000-4-2 Level 3 6/8 kV
Radiated electromagnetic field	EN 61000-4-3 Level 3 10 V/m
Burst	EN 61000-4-4 Level 3 1 kV
Electromagnetic compatibility	EN 55022 Class B
Other characteristics	
Galvanic isolation input / power supply / output	2.5 kV
Function configuration	With DIP-Switches
Operating temperature	-20°C ... +60°C
Storage temperature	-40°C ... +85°C
Mounting	Onto DIN Rail
Connections	14 AWG (2,5mm ²) / fine stranded, 12 AWG (4 mm ²) rigid
Dimensions (LxWxH)	105 x 22.5 x 112 mm / 4.13 x 0.89 x 4.41"
Weight	150 g / 0.33lb

ILPH CL / RS 422 - 485

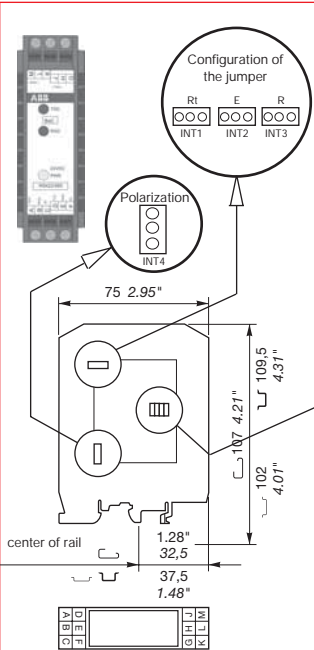

- Galvanic isolated converter for current loop to RS 422-485 (1 or 2 pairs) serial link.
- Galvanic isolation between power supply/current loop and RS 422-485/current loop
 - Active/passive 0...20 mA / 4...20 mA selectable
 - Positive or negative logic selectable
 - Baudrate up to 38,4 kbit/s (up to 2400 m)
 - Transmission distance up to 2400 m (1200 m RS 485 and 1200 m current loop)
 - Usable in "noisy" environments
 - 24 V DC power supply
 - CE marking

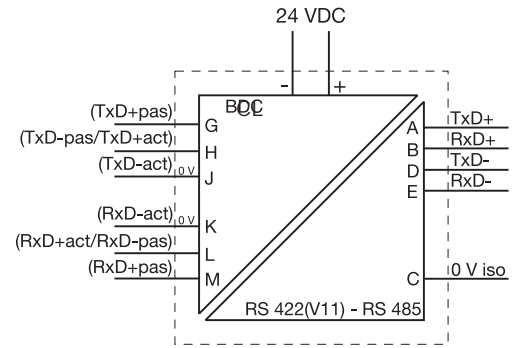

Description	Type	Catalog number	Packaging	Weight kg
Serial link interface with galvanic isolation	ILPH Bdc / RS 422 - 485	1SNA684232R2600	1	0.1
	24 VDC power supply			

LINE AMPLIFIER CONFIGURATION
 Configuration of amplifiers of the RS 422 - RS 485 (Receiver, Transmitter) line provides greater flexibility of use. The various configurations can be selected using the 2 jumpers (R INT2, E INT1) located inside the box.

RS 485 LINK ON ONE PAIR
 R INT2 R ON/OFF Jumper R in position R ON/OFF
 E INT3 E ON/OFF Jumper E in position E ON/OFF
 The Receiver and the Transmitter are activated alternately (never at the same time) depending on the status of the Current Loop Reception signal.

RS 485 LINK ON TWO PAIRS
 R INT2 R ON R ON Jumper R in position R ON
 E INT3 E ON/OFF Jumper E in position E ON/OFF
 Receiver permanently active. Transmitter controlled by the Current Loop Reception signal.

RS 422 LINK ON TWO PAIRS
 R INT2 R ON R ON Jumper R in position R ON
 E INT3 E ON E ON Jumper E in position E ON
 The Receiver and the Transmitter are both permanently active.

POLARIZATION OF THE RS 422 - RS 485 LINE
 The line must always be polarized. The ILPH is used to polarize the reception channel :
 Connection by 1 wire P+ (J1.1) with 5 Viso (J1.4)
 Connection by 1 wire P- (J1.2) with 0 Viso (J1.3)

ADAPTING THE RS 422 - RS 485 LINE
 The line must always be adapted to the level of the reception channel of each subscriber forming the end of the bus. The ILPH is used to adapt the reception channel by setting the jumper Rt correctly :

- Rt INT1 * Line adaptation, Rt = 120 Ω (Standard)
- Rt INT1 * No line adaptation, Rt = ∞

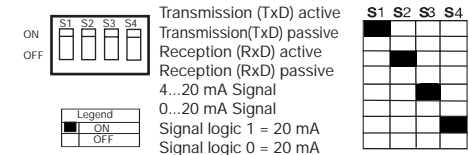

POLARIZATION
 The polarization can be configured using the INT4 jumper.
 INT4 Protection ON
 INT4 Protection OFF, used if power supply at minimum value (21,6 V).

RS 422 - RS 485 2 wire serial link

CONNECTIONS

Example of connection with a CL (current Loop) product, Transmission (TxD) in active mode and Reception (RxD) in passive mode.

Then, the ILPH must be configured and connected Reception (RxD) in passive mode and Transmission (TxD) in active mode.

Note : For any other configuration, see schematic diagram or front sticker of the product.

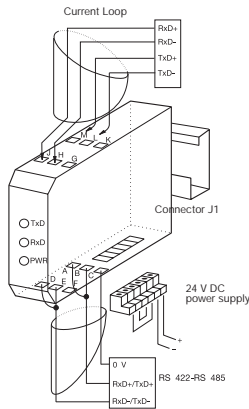

RS 422 - RS 485 4 wire serial link

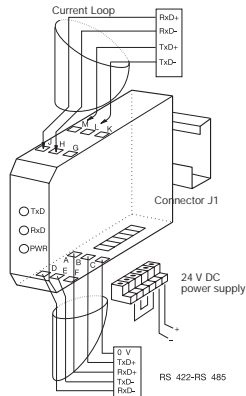

Note :

The TxD channel of the RS 422 - RS 485 link must be polarized independently too.

Technical data

Power supply	DC model polarized
Voltage	24 V DC
Voltage tolerance	+/-10%
Supply current	120 mA max.
Connections	Removable screw connector (Omniconnect)
CL interface (Current Loop 1)	active/passive 0...20 mA / 4...20 mA, mode is settable
Logic level	0 = 20 mA or 1 = 20 mA, settable
Baud rate / Transmission distance	max. 38,4 kbit/s / max. 1200 m
Connections	2,5 mm ² screw (AWG 20)
RS 422/485-2 serial link	EIA RS 485 and EIA RS 422 / CCITT V 11
Overvoltage protection	integrated (transil 8 kV 1,2/50 μs)
Baud rate / Transmission distance	max. 38,4 kbit/s / max. 1200 m
Connections	2,5 mm ² screw (AWG 20)
Traffic indication	
Voltage	1 yellow LED
Status of signal	2 green LED (RxD, TxD)
EMC behavior	
Electrostatic discharge	EN 61000-4-2 level 3 6/8 kV
Radiated electromagnetic field	EN 61000-4-3 level 3 10 V/m
Burst	EN 61000-4-4 level 3 1 kV
Electromagnetic compatibility	EN 55022 class B
Other characteristics	
Galvanic isolation between input /output and power supply / output	depending on Current Loop (active/passive)
RS 422-485 power supply	500 V DC (active) / 2000 V DC (passive)
Configuration of the operating mode	500 V DC
Operating temperature	using internal DIP switches
Storage temperature	0°C ... +50°C
Mounting	-25°C ... +80°C
DIN rail fixing (EN 50002)	any required
Wire size	snap-on mounting
Dimensions (LxBxH)	2,5 mm ² / stranded with ferrule, 4 mm ² solid
Weight	88 x 22,5 x 102 mm
	100 g

ILPH RS 232 / CL

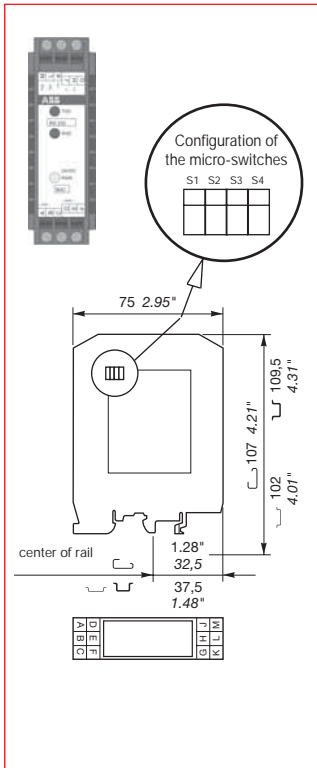

Galvanic isolated Converter for RS 232 to current loop serial link.

- Galvanic isolation between power supply/current loop and RS 232/current loop
- Active/Passive 0...20 mA / 4...20 mA selectable
- Positive or negative logic selectable
- Baudrate up to 38,4 kbit/s
- Transmission distance up to 1200 m
- Usable in "noisy" environments
- 24 V DC power supply
- CE marking

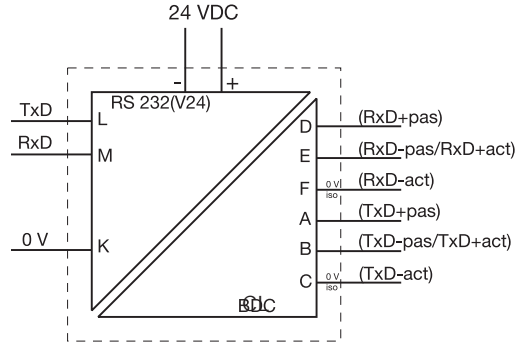

Description	Type	Catalog number	Packaging	Weight kg
Serial link interface with galvanic isolation	ILPH RS 232 / BdC 24 VDC power supply	1SNA684202R0100	1	0.1

CONFIGURATION

The various configurations can be selected using the 4 micro-switches located inside the box.

OPERATING MODE ACTIVE OR PASSIVE

The Current Loop's Transmission and Reception can be independently in active or passive mode. Select operating mode using S1 and S2.

- ON OFF
- | | | | |
|--------------------------|--------------------------|--------------------------|--------------------------|
| <input type="checkbox"/> | <input type="checkbox"/> | <input type="checkbox"/> | <input type="checkbox"/> |
|--------------------------|--------------------------|--------------------------|--------------------------|
- S1 Transmission(TxD) ON = Active / OFF = Passive
S2 Reception (RxD) ON = Active / OFF = Passive

SIGNAL LEVEL

Select signal level 4-20 mA or 0-20 mA. This selection is made using micro-switch S3

- ON OFF
- | | | | |
|--------------------------|--------------------------|--------------------------|--------------------------|
| <input type="checkbox"/> | <input type="checkbox"/> | <input type="checkbox"/> | <input type="checkbox"/> |
|--------------------------|--------------------------|--------------------------|--------------------------|
- S3 ON = 4-20 mA / OFF = 0-20 mA

Caution :

It is not possible to select a 4-20 mA signal when the Reception is in active mode.

LOGIC LEVEL

Configuration : Positive logic (0 Logic = 20 mA) or negative logic (1 Logic = 20 mA) using micro-switch S4

- ON OFF
- | | | | |
|--------------------------|--------------------------|--------------------------|--------------------------|
| <input type="checkbox"/> | <input type="checkbox"/> | <input type="checkbox"/> | <input type="checkbox"/> |
|--------------------------|--------------------------|--------------------------|--------------------------|
- S4 ON = (1 = 20 mA) / OFF = (0 = 20 mA)

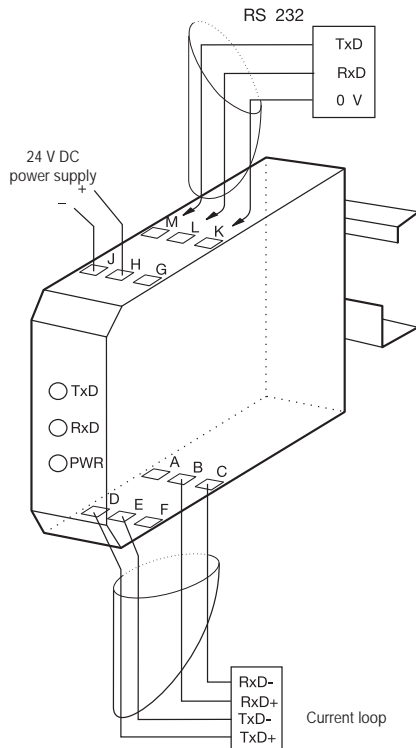

CONNECTIONS

Example of connection with a CL (Current Loop) product, Transmission (TxD) in active mode and Reception (RxD) in passive mode. Then, the ILPH must be configured and connected Reception (RxD) in passive mode and Transmission (TxD) in active mode.

CAUTION : For any other configuration, see schematic diagram or front sticker of the product.

Technical data

Power supply Voltage Voltage tolerance Supply current Connections	DC model polarized 24 V DC +/-10% 120 mA max. Removable screw connector (Omnicontact)
RS 232-1 serial link Overvoltage protection Baud rate / Transmission distance Connections	EIA RS 232 C / CCITT V 24 V 28 integrated (transil 8 kV 1,2/50 μs) max. 38,4 kbit/s / max. 15 m 2,5 mm ² screw (AWG 20)
BdC serial link (current loop) 2 Logic level Baud rate / Transmission distance Connections	active/passive 0...20 mA / 4...20 mA mode settable 0=20 mA or 1=20 mA settable max. 38,4 kbit/s / max. 1200 m 2,5 mm ² screw (AWG 20)
Traffic indication Voltage Status of signal	1 yellow LED 2 green LED (RxD, TxD)
EMC behavior Electrostatic discharge Radiated electromagnetic field Burst Electromagnetic compatibility	EN 61000-4-2 level 3 6/8 kV EN 61000-4-3 level 3 10 V/m EN 61000-4-4 level 3 1 kV EN 55022 class B
Other characteristics Galvanic isolation between Current loop / RS 232 Current loop / power supply Configuration of the operating mode Operating temperature Storage temperature Mounting DIN rail fixing (EN 50002) Wire size Dimensions (LxBxH) Weight	depending on current loop (active/passive) 500 V DC (active) / 2000 V DC (passive) 500 V DC (active) / 2000 V DC (passive) using internal DIP switches 0°C ... +50°C -25°C ... +80°C any required snap-on mounting 2,5 mm ² / stranded with ferrule, 4 mm ² solid 88 x 22,5 x 102 mm 100 g